

Service Manual



**CSA8000 Series
Communications Signal Analyzers
TDS8000 Series
Digital Sampling Oscilloscopes
071-0438-06**

Warning

The servicing instructions are for use by qualified personnel only. To avoid personal injury, do not perform any servicing unless you are qualified to do so. Refer to all safety summaries prior to performing service.

www.tektronix.com

Copyright © Tektronix, Inc. All rights reserved. Licensed software products are owned by Tektronix or its subsidiaries or suppliers, and are protected by national copyright laws and international treaty provisions.

Tektronix products are covered by U.S. and foreign patents, issued and pending. Information in this publication supercedes that in all previously published material. Specifications and price change privileges reserved.

TEKTRONIX and TEK are registered trademarks of Tektronix, Inc.

Contacting Tektronix

Tektronix, Inc.
14200 SW Karl Braun Drive
P.O. Box 500
Beaverton, OR 97077
USA

For product information, sales, service, and technical support:

- In North America, call 1-800-833-9200.
- Worldwide, visit www.tektronix.com to find contacts in your area.

Warranty 2

Tektronix warrants that this product will be free from defects in materials and workmanship for a period of one (1) year from the date of shipment. If any such product proves defective during this warranty period, Tektronix, at its option, either will repair the defective product without charge for parts and labor, or will provide a replacement in exchange for the defective product. Parts, modules and replacement products used by Tektronix for warranty work may be new or reconditioned to like new performance. All replaced parts, modules and products become the property of Tektronix.

In order to obtain service under this warranty, Customer must notify Tektronix of the defect before the expiration of the warranty period and make suitable arrangements for the performance of service. Customer shall be responsible for packaging and shipping the defective product to the service center designated by Tektronix, with shipping charges prepaid. Tektronix shall pay for the return of the product to Customer if the shipment is to a location within the country in which the Tektronix service center is located. Customer shall be responsible for paying all shipping charges, duties, taxes, and any other charges for products returned to any other locations.

This warranty shall not apply to any defect, failure or damage caused by improper use or improper or inadequate maintenance and care. Tektronix shall not be obligated to furnish service under this warranty a) to repair damage resulting from attempts by personnel other than Tektronix representatives to install, repair or service the product; b) to repair damage resulting from improper use or connection to incompatible equipment; c) to repair any damage or malfunction caused by the use of non-Tektronix supplies; or d) to service a product that has been modified or integrated with other products when the effect of such modification or integration increases the time or difficulty of servicing the product.

THIS WARRANTY IS GIVEN BY TEKTRONIX WITH RESPECT TO THE PRODUCT IN LIEU OF ANY OTHER WARRANTIES, EXPRESS OR IMPLIED. TEKTRONIX AND ITS VENDORS DISCLAIM ANY IMPLIED WARRANTIES OF MERCHANTABILITY OR FITNESS FOR A PARTICULAR PURPOSE. TEKTRONIX' RESPONSIBILITY TO REPAIR OR REPLACE DEFECTIVE PRODUCTS IS THE SOLE AND EXCLUSIVE REMEDY PROVIDED TO THE CUSTOMER FOR BREACH OF THIS WARRANTY. TEKTRONIX AND ITS VENDORS WILL NOT BE LIABLE FOR ANY INDIRECT, SPECIAL, INCIDENTAL, OR CONSEQUENTIAL DAMAGES IRRESPECTIVE OF WHETHER TEKTRONIX OR THE VENDOR HAS ADVANCE NOTICE OF THE POSSIBILITY OF SUCH DAMAGES.

Table of Contents

General Safety Summary	ix
Service Safety Summary	xi
Preface	xiii
Manual Structure	xiii
Manual Conventions	xiii
Related Documentation	xiv

Operating Information

Installation	1-1
Check the Environmental Requirements	1-1
Site Considerations	1-1
Operating Requirements	1-1
Rackmount Requirements	1-2
Install the Sampling Modules	1-2
Check Your Sampling Module Manual(s)	1-2
Maximum Configuration	1-3
Connect the Peripherals	1-3
Power On the Instrument	1-5
Powering Off the Instrument	1-6
Software Installation	1-7
Description	1-7
Software Release Notes	1-7
Operating System Reinstallation	1-7
System Hard Drive Rebuild	1-8
System Diagnostics	1-8
Windows Safe Mode	1-8

Theory of Operation

Logic Conventions	2-1
Mainframe Overview	2-1
Input Signal Path	2-1
Display Panel	2-2
Front Panel	2-2
Rear Panel	2-2
Low Voltage Power Supply	2-2
Fans	2-3
Electrical Sampling Modules Overview	2-3
80E04 Electrical TDR/Sampling Module	2-4
Optical Sampling Modules Overview	2-4
80C01 Optical Sampling Module	2-6
80C02 Optical Sampling Module	2-7
80C03 Optical Sampling Module	2-7
80C04 Optical Sampling Module	2-8
80C05 Optical Sampling Module	2-9
80C06 Optical Sampling Module	2-9
80C07 Optical Sampling Module	2-9

80C07B Optical Sampling Module	2-9
80C08 Optical Sampling Module	2-10
80C08B Optical Sampling Module	2-10
80C08C Optical Sampling Module	2-10
80C09 Optical Sampling Module	2-11
80C10 Optical Sampling Module	2-11
80C11 Optical Sampling Module	2-11
80C12 Optical Sampling Module	2-11
80A01 Trigger Prescale Preamplifier Module	2-12
80A02 EOS/ESD Protection Module	2-12
80A05 Electrical Clock Recovery Module	2-13
80A06 PatternSync Trigger Module	2-13
82A04 Phase Reference Module	2-14

Adjustment Procedures

Adjustment Interval	3-1
Adjustment Environment	3-1
Adjustment After Repair	3-1
Required Equipment	3-2
Instrumentation Setup	3-2
Main Instrument Adjustments	3-3
DC Calibrator Adjust	3-3
DC Calibrator Adjust Verification	3-4
Internal 10 MHz Adjust	3-5

Maintenance

Preventing ESD	4-1
Inspection and Cleaning	4-2
General Care	4-2
Flat Panel Display Cleaning	4-2
Exterior	4-3
Interior	4-4
Removal and Installation Procedures	4-7
Preparation	4-7
Procedures for External Modules	4-9
Front-Panel Knobs	4-9
Trim and Carrying Handle	4-10
Bottom Cover	4-11
Covers	4-13
Line Fuses and AC power cord connector	4-16
Procedures for Modules	4-21
Front Panel Assembly	4-21
Front Panel Board	4-23
Front Panel Keypad	4-24
Display Assembly	4-25
Display Adapter Board	4-27
Standby/On Switch Flex Circuit Removal	4-29
Floppy Disk Drive	4-31
Hard Disk Drive	4-32
CD Drive	4-34
Fan Assembly Removal	4-35

Front and Rear Power Distribution Boards	4-37
Low-Voltage Power Supply	4-38
NLX Board	4-40
Microprocessor	4-43
PC Processor Board	4-45
Acquisition Assembly	4-47
Large Module Interface Circuit Board	4-53
Module Slot Doors	4-55
Electrical Modules	4-64
Exchanging the Electrical Sampling Module	4-65
Replacing the sampling module chassis	4-65
Reinstalling exchange module serial number	4-65
Optical Modules	4-66
80A00 and 82A00 Series Modules	4-67
Troubleshooting	4-69
Check for Common Problems	4-69
Equipment Required	4-72
Isolating Failures between the 80E0X/80C0X Modules or the Mainframe ...	4-72
Isolating to a Board if Power Will Not Come Up	4-73
Checking the Power Supply Voltages	4-74
If the instrument Will Not Boot	4-75
Booting Into Windows	4-76
PPC and NLX PC Diagnostics	4-76
Power-On Diagnostics	4-76
QAPlus/Win	4-76
Diagnostics	4-77
Firmware Updates	4-77
After Repair	4-78
Installing the Instrument Model and Serial Number	4-78
Update/Restore the NLX Board CMOS	4-79
Repackaging Instructions	4-81
Packaging	4-81
Shipping to the Service Center	4-81

Diagrams

Symbols	5-1
CSA8000 and TDS8000 Series Block Diagram	5-2
Electrical Sampling Modules Block Diagram	5-3
Optical Sampling Modules Block Diagrams	5-4
80A01 Block Diagram	5-26
80A02 Block Diagram	5-27
80A05 Block Diagram	5-28
80A06 Block Diagram	5-29
82A04 Block Diagram	5-30

Replaceable Parts

Parts Ordering Information	6-1
Module Servicing	6-1
Using the Replaceable Parts List	6-2

List of Figures

Figure 1-1: Compartments for sampling modules	1-3
Figure 1-2: Locations of peripheral connectors on rear panel	1-4
Figure 1-3: Line fuse and power cord connector locations, rear panel	1-5
Figure 1-4: On/Standby switch location	1-6
Figure 3-1: Adjustment setup using the DMM	3-3
Figure 3-2: Adjustment setup using the signal generator	3-5
Figure 4-1: Knob removal	4-9
Figure 4-2: Trim removal	4-11
Figure 4-3: Bottom cover removal	4-12
Figure 4-4: Cover removal	4-14
Figure 4-5: Cover removal	4-15
Figure 4-6: Line fuses and line cord removal	4-17
Figure 4-7: External modules	4-18
Figure 4-8: Internal modules	4-19
Figure 4-9: Acquisition modules	4-20
Figure 4-10: Front panel assembly removal	4-22
Figure 4-11: J1 flex cable connector removal	4-23
Figure 4-12: Front panel board and keyboard removal	4-24
Figure 4-13: Display removal	4-26
Figure 4-14: Touch panel and LCD assembly removal	4-27
Figure 4-15: Display adaptor board removal	4-28
Figure 4-16: Connector clip assembly	4-28
Figure 4-17: Standby/On switch flex circuit removal	4-30
Figure 4-18: Floppy disk drive removal	4-31
Figure 4-19: Hard drive disk removal	4-33
Figure 4-20: Removing the hard disk drive from the cartridge	4-33
Figure 4-21: CD drive and bracket removal	4-35
Figure 4-22: Fan assembly removal	4-36
Figure 4-23: Front and rear power distribution board removal	4-37
Figure 4-24: Low-voltage power supply removal	4-39
Figure 4-25: NLX assembly removal	4-41
Figure 4-26: Riser adapter and NLX board removal	4-42
Figure 4-27: Microprocessor removal	4-44
Figure 4-28: Processor board removal	4-46

Figure 4-29: T-10 screws and threaded posts	4-48
Figure 4-30: Thermal cover removal (8200 only)	4-49
Figure 4-31: Acquisition circuit board assembly removal (8000) ...	4-50
Figure 4-32: Acquisition circuit board assembly removal (8000B) .	4-51
Figure 4-33: Acquisition circuit board assembly removal (8200) ...	4-52
Figure 4-34: Large module interface circuit board removal (8000 and 8000B)	4-54
Figure 4-35: Large module interface circuit board removal (8200) .	4-55
Figure 4-36: Small and Large module chassis removal	4-57
Figure 4-37: Module door spring removal	4-59
Figure 4-38: Module slot door removal	4-60
Figure 4-39: Module ejector handles removal	4-62
Figure 4-40: Spring arm position	4-63
Figure 4-41: Electrical module hardware removal	4-64
Figure 4-42: Optical module cover removal	4-66
Figure 4-43: 80A00 and 8200 series parts removal (80A01 shown) .	4-67
Figure 4-44: Location of power-on and over current LEDs	4-73
Figure 4-45: Location of debug pins	4-74
Figure 4-46: Connectors J1 and J2	4-75
Figure 5-1: Block diagram for CSA8000 and TDS8000 Series Instruments	5-2
Figure 5-2: Block diagram for the 80E00 Series Electrical Sampling Modules	5-3
Figure 5-3: 80C01 Optical sampling block diagram	5-4
Figure 5-4: 80C01 Optical sampling with clock recovery block diagram	5-5
Figure 5-5: 80C02 Optical sampling block diagram	5-6
Figure 5-6: 80C02 Optical sampling with clock recovery block diagram	5-7
Figure 5-7: 80C03 Optical sampling block diagram	5-8
Figure 5-8: 80C03 Optical sampling with clock recovery block diagram	5-9
Figure 5-9: 80C04 Optical sampling block diagram	5-10
Figure 5-10: 80C04 Optical sampling block diagram with clock recovery	5-11
Figure 5-11: 80C05 Optical sampling block diagram	5-12
Figure 5-12: 80C06 Optical sampling block diagram	5-13
Figure 5-13: 80C07 and 80C07B Optical sampling block diagram .	5-14
Figure 5-14: 80C07 and 80C07B Optical sampling with CR1 clock recovery block diagram	5-15

Figure 5-15: 80C08/80C08B/80C08C Optical sampling block diagram	5-16
Figure 5-16: 80C08/80C08B/80C08C Optical sampling with CR1, CR2, & CR4 clock recovery block diagram	5-17
Figure 5-17: 80C09 Optical sampling block diagram	5-18
Figure 5-18: 80C09 Optical sampling with CR1 clock recovery block diagram	5-19
Figure 5-19: 80C10 Optical sampling block diagram	5-20
Figure 5-20: 80C11 Optical sampling block diagram	5-21
Figure 5-21: 80C11 Optical sampling with CR1 clock recovery option block diagram	5-22
Figure 5-22: 80C11 Optical sampling with CR2 and CR3 clock recovery option block diagram	5-23
Figure 5-23: 80C11 Optical sampling with CR4 clock recovery option block diagram	5-24
Figure 5-24: 80C12 Optical sampling block diagram	5-25
Figure 5-25: 80A01 block diagram	5-26
Figure 5-26: 80A02 block diagram	5-27
Figure 5-27: 80A05 block diagram	5-28
Figure 5-28: 80A06 block diagram	5-29
Figure 5-29: 82A04 block diagram	5-30
Figure 6-1: External parts	6-7
Figure 6-2: Front panel and drives	6-10
Figure 6-3: Power supply	6-13
Figure 6-4: Acquisition	6-16
Figure 6-5: 8000 and 8000B coaxial cables	6-18
Figure 6-6: 8200 coaxial cables	6-20
Figure 6-7: 80E01, 80E02, 80E03, and 80E04 modules	6-22
Figure 6-8: 80E05 module (Option 10G shown)	6-23
Figure 6-9: 80E06 module	6-24
Figure 6-10: Optical modules	6-25
Figure 6-11: 80A01 module	6-26
Figure 6-12: 82A04 module	6-28
Figure 6-13: 80A06 module	6-30

List of Tables

Table 1-1: Additional accessory connection information	1-3
Table 1-2: Line fuses	1-5
Table 2-1: Module optical/electrical split	2-6
Table 3-1: Adjustments required for module replaced	3-1
Table 3-2: Required equipment and materials	3-2
Table 4-1: External inspection check list	4-3
Table 4-2: Internal inspection check list	4-4
Table 4-3: Tools required for module removal	4-8
Table 4-4: Failure symptoms and possible causes	4-69
Table 4-5: Power supply voltages	4-75
Table 4-6: Action required for module replaced	4-78

General Safety Summary

Review the following safety precautions to avoid injury and prevent damage to this product or any products connected to it. To avoid potential hazards, use this product only as specified.

Only qualified personnel should perform service procedures.

While using this product, you may need to access other parts of the system. Read the *General Safety Summary* in other system manuals for warnings and cautions related to operating the system.

To Avoid Fire or Personal Injury

Use Proper Power Cord. Use only the power cord specified for this product and certified for the country of use. Power cord needed only in the mainframe, not modules.

Connect and Disconnect Properly. Do not connect or disconnect probes or test leads while they are connected to a voltage source.

Ground the Product. The mainframe is grounded through the grounding conductor of the power cord. To avoid electric shock, the grounding conductor must be connected to earth ground. Before making connections to the input or output terminals of the product, ensure that the product is properly grounded.

Ground the Product. The modules are indirectly grounded through the grounding conductor of the mainframe power cord. To avoid electric shock, the grounding conductor must be connected to earth ground. Before making connections to the input or output terminals of the product, ensure that the product is properly grounded.

Observe All Terminal Ratings. To avoid fire or shock hazard, observe all ratings and markings on the product. Consult the product manual for further ratings information before making connections to the product.

Do not apply a potential to any terminal, including the common terminal, that exceeds the maximum rating of that terminal.

Do Not Operate Without Covers. Do not operate this product with covers or panels removed.

Use Proper Fuse. Use only the fuse type and rating specified for this product.

Avoid Exposed Circuitry. Do not touch exposed connections and components when power is present.

Wear Eye Protection. Wear eye protection if exposure to high-intensity rays or laser radiation exists.

Do Not Operate With Suspected Failures. If you suspect there is damage to this product, have it inspected by qualified service personnel.

Do Not Operate in Wet/Damp Conditions.

Do Not Operate in an Explosive Atmosphere.

Keep Product Surfaces Clean and Dry.

Provide Proper Ventilation. Refer to the manual's installation instructions for details on installing the product so it has proper ventilation.

Symbols and Terms

Terms in this Manual. These terms may appear in this manual:



WARNING. Warning statements identify conditions or practices that could result in injury or loss of life.



CAUTION. Caution statements identify conditions or practices that could result in damage to this product or other property.

Terms on the Product. These terms may appear on the product:

DANGER indicates an injury hazard immediately accessible as you read the marking.

WARNING indicates an injury hazard not immediately accessible as you read the marking.

CAUTION indicates a hazard to property including the product.

Symbols on the Product. The following symbols may appear on the product:



CAUTION
Refer to Manual



WARNING
High Voltage



Protective Ground
(Earth) Terminal



Mains Disconnected
OFF (Power)



Mains Connected
ON (Power)



Standby

Service Safety Summary

Only qualified personnel should perform service procedures. Read this *Service Safety Summary* and the *General Safety Summary* before performing any service procedures.

Do Not Service Alone. Do not perform internal service or adjustments of this product unless another person capable of rendering first aid and resuscitation is present.

Disconnect Power. To avoid electric shock, switch off the instrument power, then disconnect the power cord from the mains power.

Use Care When Servicing With Power On. Dangerous voltages or currents may exist in this product. Disconnect power, remove battery (if applicable), and disconnect test leads before removing protective panels, soldering, or replacing components.

To avoid electric shock, do not touch exposed connections.

Preface

This is the service manual for the:

- CSA8000, CSA8000B, and CSA8200 Communications Signal Analyzers
- TDS8000, TDS8000B, and TDS8200 Digital Sampling Oscilloscopes
- modules that install in the instruments (except the 80A03 module)

NOTE. *The 80A03 instruction manual contains its own specifications and servicing information.*

Read this preface to learn how this manual is structured, what conventions it uses, and where you can find other information related to servicing this product. Read the *Introduction* following this preface for safety and other important background information needed before servicing this product.

Manual Structure

This manual is divided into chapters, which are made up of related subordinate topics. These topics can be cross referenced as sections.

Be sure to read the introductions to all procedures. These introductions provide important information needed to do the service correctly, safely, and efficiently.

Manual Conventions

This manual uses certain conventions that you should become familiar with before attempting service.

Modules

Throughout this manual, the term *module* appears. A module is composed of electrical and mechanical assemblies, circuit cards, interconnecting cables, and a user-accessible front panel. References to a module are different than references to products such as “Sampling modules”, “Phase Reference modules”, or “Accessory modules” which are products installed in the instrument compartments.

Replaceable Parts

This manual refers to any field-replaceable assembly or mechanical part by its name or generically as a replaceable part. In general, a replaceable part is any circuit board or assembly, such as a hard disk drive, or a mechanical part, such as I/O port connectors, that is listed in the replaceable parts list of Chapter 8.

Safety

Symbols and terms related to safety appear in the *General Safety Summary* found at the beginning of this manual.

Related Documentation

The following documents relate to the instruments this service manual supports:

- *CSA8000 and TDS8000 Specifications and Performance Verification manual*. Tektronix part number 071-xxxx-XX.
- *CSA8200 and TDS8200 Quick Start User manual*. Tektronix part number 071-1482-XX. This document also contains specification changes when using the 82A04 Phase Reference module.
- *CSA8000 and TDS8000 Online Help*. Installed with the application software and accessed from the instrument Help menu.
- *CSA8000 & TDS8000 Programmer Guide*. An online document accessed from the instrument Help menu.
- *80E01, 80E02, 80E03, 80E04, and 80E06 Electrical Sampling Modules User manual*. Tektronix part number 071-0434-XX.
- *80C00 Series Optical Sampling Modules User manual*. Tektronix part number 071-0435-XX.
- *80A01 Trigger Prescale Limiting Preamplifier Module User manual*. Tektronix part number 071-0873-XX.
- *80A02 EOS/ESD Protection Module Instructions*. Tektronix part number 071-1317-XX
- *80A03 TekConnect Probe Interface Module Instructions*. Tektronix part number 071-1298-XX.
- *80A05 Electrical Clock Recovery Module User manual*. Tektronix part number 071-1467-XX.
- *80A06 PatternSync Trigger Module Instructions*. Tektronix part number 071-xxx-XX.
- *CSA8000/TDS8000 Rackmount Kit Instructions*. Tektronix part number 071-0696-XX.
- *CSA8000B and TDS8000B User manual*. Tektronix part number 071-1099-XX.
- *TDR Z-Meas Application Online Help*. Ships with this product on a separate CD. Provides information about this TDR Impedance Measuring application that implements the TDR calibration procedures specified by the IPC TM-650 test method.
- *Fast NRZ Application Online Help*. Ships with this product on a separate CD. Provides information about this application that improves throughput for optical eye-pattern mask testing.



Operating Information

Installation

This section covers installation of the instrument, addressing the following topics:

- *Check the Environment Requirements* on page 1-1
- *Install the Sampling Modules* on page 1-2
- *Connect the Peripherals* on page 1-3
- *Power On the Instrument* on page 1-5
- *Powering Off the Instrument* on page 1-6

The basic operating software is already installed on the hard disk. If reinstallation of software becomes needed, see the following topic:

- *Software Installation* on page 1-7

Check the Environmental Requirements

Read this section before attempting any installation procedures. This section describes site considerations, power requirements, and ground connections for your instrument.

Site Considerations

The instrument is designed to operate on a bench or on a cart in the normal position (on the bottom feet). For proper cooling, at least two inches (5.1 cm) of clearance is recommended on the sides of the instrument.

You can also operate the instrument while it rests on its rear feet. Make sure that you properly route any cables coming out of the rear of the instrument to avoid damaging them.



CAUTION. *Keep the bottom of the instrument clear of obstructions to ensure proper cooling.*

Operating Requirements

Specifications in chapter 1 list the operating requirements for the instrument. Power source and temperature, humidity, and altitude are listed.

Rackmount Requirements

If this instrument is rackmounted, see the *TDS8000 & CSA8000 Rackmount Instructions* for additional site considerations or operating requirements. This document ships with the Option 1R (rackmount kit).

Install the Sampling Modules



CAUTION. Do not install or remove any sampling modules while the instrument is powered on.

Always power the instrument down before attempting to remove or insert any sampling module.



WARNING. Sampling modules are inherently vulnerable to static damage. Always observe static-safe procedures and cautions as outlined in your sampling module user manual.

Check Your Sampling Module Manual(s)

Read the sampling-module user manual for instructions on how to install your sampling modules.

NOTE. After first installing a sampling module(s) or after moving a sampling module from one compartment to another, you should run compensation from the Utilities menu to ensure the instrument meets its accuracy specifications. You must run a compensation (accessed from the Utilities menu) whenever the extender configuration is changed from that present at the last compensation. In short, if you install or remove an 80E00 extender, run a compensation. If you exchange a extender for one of a different length, run a compensation. For instructions on running a compensation, see Perform the Compensation on page NO TAG.

Figure 1-1 shows compartments for both large and small sampling modules, along with the plug-in connector for the ESD wrist strap that you must use to install and remove these modules.

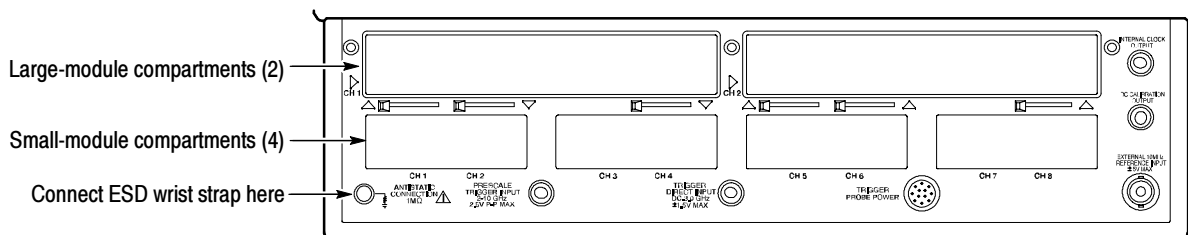

Figure 1-1: Compartments for sampling modules

Maximum Configuration

You can install up to two large sampling modules and four small modules for a maximum of 10 inputs. Of these 10 inputs, only eight inputs can be active at one time. Also, note that installing a large module may disable a small-module compartment. Refer to the user manual for compartment interaction for the various CSA and TDS 8000 Series mainframes.

Install probes, cables, and other connection accessories to your sampling modules as appropriate for your application and sampling module. Again, consult your sampling-module and connection-accessory manuals. Continue with the next section after installing the sampling modules.

Connect the Peripherals

The peripheral connections are mostly the same as those you would make on a personal computer. The connection points are shown in Figure 1-2. See Table 1-1 on page 1-3 for additional connection information.



WARNING. Before installing peripheral accessories to connectors (mouse, keyboard, etc.), power down the instrument. See Powering Off the Instrument on page 1-6.

Table 1-1: Additional accessory connection information

Item	Description
Monitor	If you use a non-standard monitor, you may need to change the Windows display settings to achieve the proper resolution for your monitor.
Printer	Connect the printer to the EPP (enhanced parallel port) connector directly. If your printer has a DB-25 connector, use the adapter cable that came with your printer to connect to the EPP connector.
Rackmount	Refer to the <i>CSA8000 & TDS8000 Rackmount Installation Instructions</i> for information on installing the rackmount kit.

Table 1-1: Additional accessory connection information (cont.)

Item	Description
Other	Refer to the Application release notes (readme.txt) in the C:\Program Files\TDSCSA8000\System directory of the instrument for possible additional accessory installation information not covered in this manual.

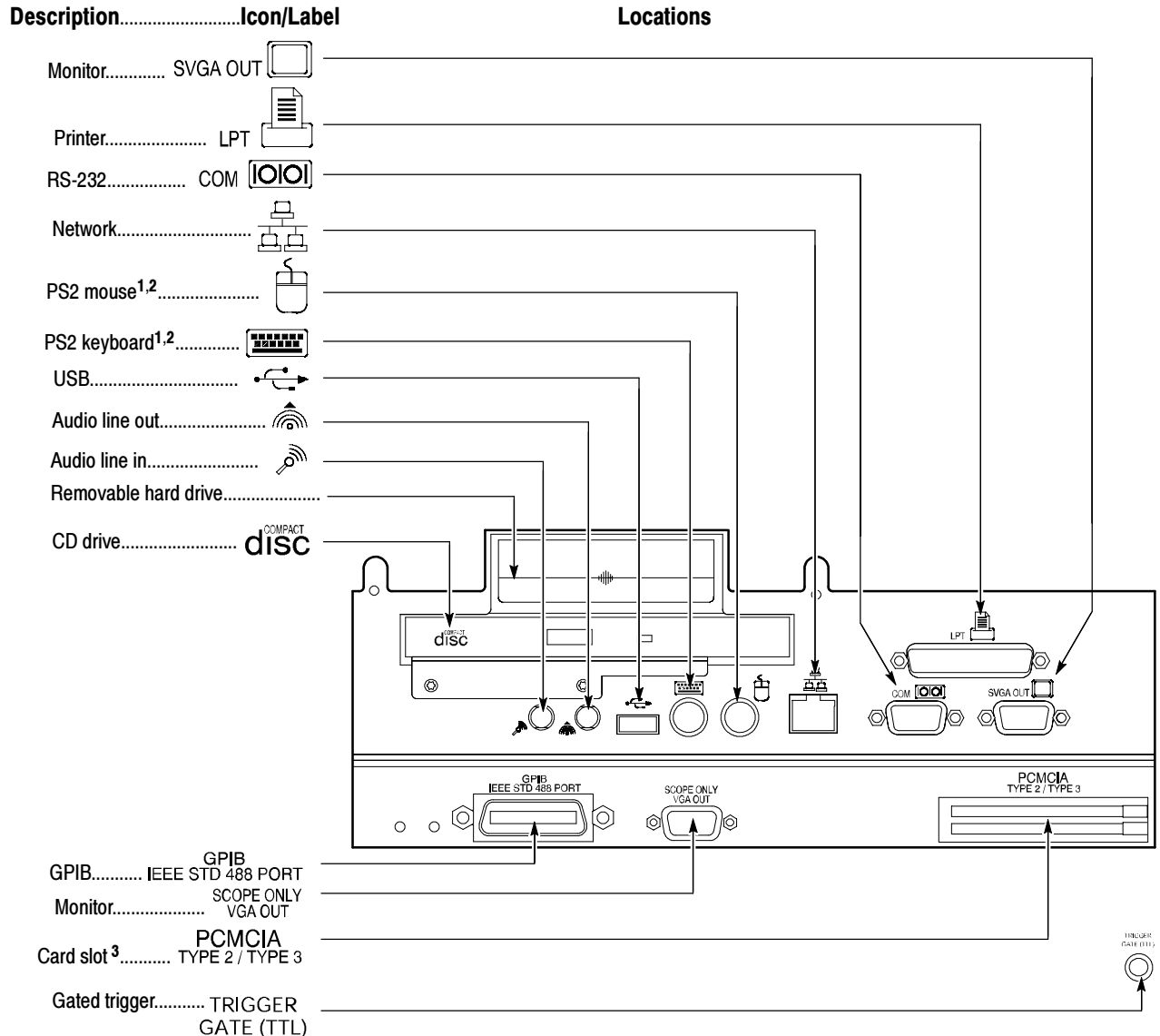

¹ Product ships with a USB keyboard, that plugs into the USB port, and a USB mouse that plugs into the back of the keyboard

² Some instruments ship with the keyboard and mouse ports reversed.

³ Card slot not available on CSA/TDS8000B or CSA/TDS8200 instruments.

Figure 1-2: Locations of peripheral connectors on rear panel

Power On the Instrument

Follow these steps to power on the instrument for the first time.

1. Check that the line fuses are correct for your application. Both fuses must be the same rating and type. Fuse types require a unique cap and fuseholder. See Table 1-2 and Figure 1-3.

Table 1-2: Line fuses

Fuse type	Rating	Fuse part number	Cap & fuseholder part number
0.25 x 1.250 inch	8 A, fast blow, 250 V	159-0046-00	200-2264-00
5 x 20 mm	6.3 A, fast blow, 250 V	159-0381-00	200-2265-00

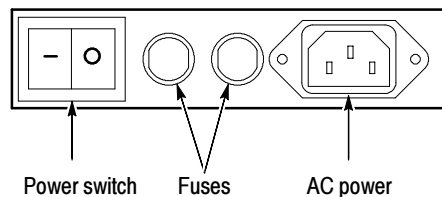

Figure 1-3: Line fuse and power cord connector locations, rear panel



CAUTION. Connect accessories (such as a PS2 keyboard and mouse, and other accessories) before applying power to the product. Some accessories can be damaged if connecting or disconnecting with the instrument power on.

USB devices can be plugged or unplugged without first turning power off.

2. Connect the keyboard and mouse, observing the caution above.

NOTE. Connection of the keyboard and mouse is optional. You can operate most features without them, using the front-panel controls and the touchscreen.

3. Connect the power cord.
4. Turn the Power switch on at the rear panel. (See Figure 1-3 on page 1-5 for switch location.)
5. Push the On/Standby switch to power on the instrument (see Figure 1-4 for the switch location).

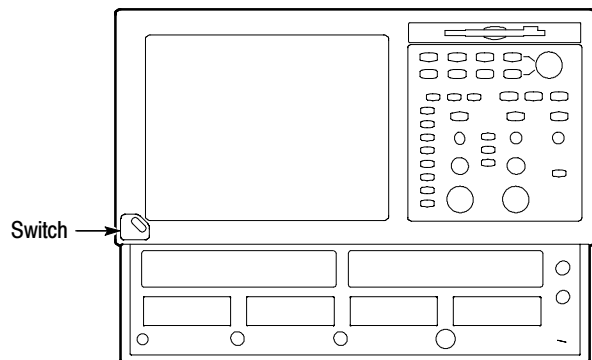

Figure 1-4: On/Standby switch location

6. Wait for the boot routine and low-level self test to complete.
7. Follow any instructions on the screen.

The internal setup software will automatically configure your instrument and install all required devices, depending on the installed accessories.

Powering Off the Instrument

The instrument has a built-in soft power-down function that safely powers down the instrument when you push the On/Standby button. You do not need to close the UI application or Windows before using the On/Standby button.

To completely remove power to the instrument, first soft power-down the instrument using the On/Standby button, and then set the power switch on the rear panel to off.

You can restore the UI application to the screen by clicking its button in the Windows Task bar.

Software Installation

This section describes how to install the system software found on the 8000 Series OS Restore CDs that accompany this product. The instrument ships with the product software installed, *so only perform these procedures if reinstallation becomes necessary.*

Description

The product software comprises two parts:

- **Microsoft Windows.** The Microsoft Windows operating system comes preinstalled on the instrument. Microsoft Windows is the operating system on which the user-interface application of this product runs. The CDROM(s) included with your instrument contain the Windows operating system which can be used to rebuild the instrument hard drive.

If you need to reinstall Windows, you may be able to do so without rebuilding the instrument hard drive. See *Operating System Reinstallation* on page 1-7 for more information.

- **User Interface (UI) Application.** The UI application complements the hardware controls of the front panel, allowing complete set up of all instrument features. The CDROM(s) included with your instrument contain the UI application for reinstallation if rebuilding the hard drive.

Tektronix provides updates to the user interface application on a regular basis. Updates can be obtained by visiting the Tektronix Web site at www.tektronix.com.

Software Release Notes

Read the software release notes in the Release Notes file (or Readme file for earlier versions), if present, on the CDROM containing the user interface application before performing any installation procedures. This file contains additional installation and operation information that supercedes other product documentation.

After installation, you can also read the copy from a directory on the product:

C:\Programs Files\TDSCSA8000\System

Operating System Reinstallation

If reinstalling Microsoft Windows becomes necessary, use the Windows Operating System restore CD(s) that came with your instrument. Follow the installation procedures provided with the CD(s). The procedures vary between instruments and the version of Microsoft Windows being installed.

NOTE. *Only do the reinstall if the Microsoft Windows operating system is missing or corrupted.*

System Hard Drive Rebuild

If you cannot reboot from the instrument hard drive, you must rebuild the instrument hard drive. This process will return the hard disk to the its original condition present when the instrument shipped.

Data and programs you may have installed will be lost when rebuilding the hard drive.

If you must rebuild the system hard drive, use the System Rebuild CD(s) that shipped with the instrument. Follow the instructions in the booklet found in the CD case.

System Diagnostics

In case of instrument problems, you may wish to run the system diagnostics. If so, see the procedure *Perform the Diagnostics*, on page NO TAG.

Windows Safe Mode

If the instrument is turned off before the operating system boots, or if you've installed a third-party product with a driver incompatible with instrument start up, Windows will open in Safe mode. The touchscreen will be inoperable; therefore, you must install the standard-accessory mouse and keyboard to operate the instrument.

When you have finished investigating and removed any barrier to Windows start-up, you can reboot. If the instrument no longer boots to Safe mode, you can remove the keyboard and mouse if desired.



Theory of Operation

Theory of Operation

This chapter describes the electrical operation of the instrument and sampling modules. The diagrams in Chapter 9 show the interconnections of the major circuit blocks.

Logic Conventions

The instrument contains many digital logic circuits. This manual refers to these circuits with standard logic symbols and terms. Unless otherwise stated, all logic functions are described using the positive-logic convention: the more positive of the two logic levels is the high (1) state, and the more negative level is the low (0) state. Signal states may also be described as “true” meaning their active state or “false” meaning their nonactive state. The specific voltages that constitute a high or low state vary among the electronic devices.

Mainframe Overview

This mainframe overview describes the basic operation of each functional circuit block as shown in Figure 5-1 on page 5-2.

General

The instrument control system is a dual Wintel/PowerPC based processor board. The platform features VGA resolution flat-panel display, transparent touch screen and user front-panel with direct access to commonly used scope functions. The instrument is also equipped with a mouse pointing device to facilitate access to more advanced scope functions

Input Signal Path

A signal enters the instrument through a direct coaxial connection to the input connector on a sampling module, or a real time probe connected to the sampling module channel.

Acquisition System. The acquisition system conditions the input signals, samples them, converts them to digital signals, and controls the acquisition process under direction of the processor system. The acquisition system includes the multi-source trigger, acquisition timebase, and acquisition mode generation and control circuitry. The acquisition board is located in the bottom compartment of the instrument and can accommodate four dual-channel sampling Plug-ins, two one-channel optical plug-ins and a trigger/holdoff subsystem. Up to 8 vertical channels are accommodated simultaneously. Channels 1 and 2 are either large or small slots. The presence of an module in one or both large slots displaces the small slot functionality in the leftmost Channel 1 - Channel 2 small slot. The

external trigger and all small slot channels feature a Tekprobe Level 2 probe power connector for additional front end signal conditioning functions like high input-impedance real-time probes.

Processor System. The processor system contains a dual Wintel/PowerPC. The basic instrument configuration supports up to eight channels labeled Ch1 through Ch 8, provides two external trigger inputs for direct and prescaled triggering through built-in prescaler and is able to support two optional internal trigger sources associated with the large slot channels mapped onto electrical channels 1 and 2.

Display Panel Color LCD display Active-matrix touch panel.

Display System. The display system sends the text and waveform information to the display panel.

Touch Panel. The Display board sends information to the processor. Any changes in their settings are reported to the processor system.

Front Panel The front panel board reads the front-panel switches and knob sensors. Any changes in their settings are reported to the processor system. The front panel board also turns the LEDs on and off and generates the bell signal.

Front-panel menu switches are also read by the PPC processor board. The processor sends any changes in menu selections to the processor system. The ON/STBY switch is one of the menu switches. However, it is not read by the front panel board, but passes through the front panel board to the low voltage power supply.

Rear Panel The hard drive and CD Rom provides access to stored waveform data and to load software to customized your instrument with your measurement needs. The GPIB allows for external control of the instrument.

You can make hardcopies on the GPIB and RS-232 ports. Other ports from the front panel board: PC cardbus x 2 and cal adjust lock.

Outputs from the NLX board: SVGA, USB (1), sound, serial, parallel, Ethernet, mouse, keyboard.

Low Voltage Power Supply The low voltage power supply is a switching power converter with active power factor control. It supplies power to all of the circuitry in the instrument.

The principal POWER switch, located on the rear panel, controls all power to the instrument including the Low Voltage Power Supply. The ON/STBY switch,

located on the front panel, also controls all of the power to the instrument except for part of the circuitry in the Low Voltage Power Supply.

The power supply sends a power fail (~PF) warning to the processor system if the power is going down.

Fans The fan assembly provides forced air cooling for the instrument. The fans are controlled by the PPC processor.

Electrical Sampling Modules Overview

The 80E01 and 80E06 are one-channel sampling modules, 50 GHz and 70 GHz, respectively; the 80E02, 80E03, and 80E04 are two-channel modules, 12.5 GHz, 20 GHz, and 20 GHz samplers, respectively. The 80E01 module has a 7 ps rise time, the 80E02 has a 28 ps rise time, the 80E03 and 80E04 modules have a 17.5 ps rise time, and the 80E06 has a 5.0 ps rise time.

For the 80E02 and 80E03, a single strobe delivered from the instrument mainframe to both acquisition channels controls the timing of the strobe assertion to both channels. If channel-to-channel deskew is zero, the sampling coincidence between channels is very close. Acquisition deskew function is carried out by making separate acquisitions over individual acquisition windows.

For the 80E01 and 80E06, an individual strobe delivered from the instrument mainframe to the acquisition channel controls the timing of the strobe assertion to the channel. Acquisition deskew function is carried out by moving the strobe timing for the channel to a unique acquisition window.

Each electrical channel features a Tekprobe Level 2 probe power connector for attachment of a real time probe. The control of this probe is a mainframe function.

All module calibration signals are derived from a 2.5 V precision voltage reference internal to the sampling module. Settings derived from this reference are stored in a non-volatile EEPROM in the sampling module, although the responsibility for the execution of these settings is with the mainframe.

For major functional circuit blocks refer to Figure 5-2 on page 5-3.

80E04 Electrical TDR/Sampling Module

The 80E04 TDR/Sampling module is a two-channel, low noise, 17.5 ps rise time sampler. Each channel is also capable of generating its own Time Domain Reflectometry (TDR) step. The 80E04 sampling module risetime is 17.5 ps.

For the 80E04 a single strobe delivered from the instrument mainframe to both acquisition channels controls the timing of the strobe assertion to both channels. If channel-to-channel deskew is zero, the sampling coincidence between channels is very close. Acquisition deskew function is carried out by making separate acquisitions over acquisition windows.

Each electrical channel features a Tekprobe Level 2 probe power connector for attachment of a real time probe. The control of this probe is a mainframe function.

All module calibration signals are derived from a 2.5 V precision voltage reference internal to the sampling module. Settings derived from this reference are stored in a non-volatile EEPROM in the sampling module, although the responsibility for the execution of these settings is with the mainframe.

When used in the acquisition mode (that is, with the TDR step generator turned off) each channel functions as a normal sampling input. Both channels are strobed simultaneously from a single strobe generator contained within the sampling module, so time coincidence between the two channels is stable.

In the TDR mode, a fast rise time step is generated internally for each channel and applied to the input signal path for that channel. The acquisition portion of the TDR/sampling module remains functional for monitoring the primary step and its reflected components. The sampling module provides two self-contained TDR channels. The polarity of the output step can be selected independently for each channel. This allows differential or common mode testing of two coupled lines as well as independent testing of isolated lines.

For major functional circuit blocks refer to Figure 5-2 on page 5-3.

Optical Sampling Modules Overview

80C0X and 80C0X-CR optical modules share the same mechanical package and are built with a common circuit board. Different functionality within the modules (current and future modules) is achieved by installing different O/E modules, filters and clock recovery boards along with setting the sampler bandwidth as demanded. The key features supported in the module are:

- A one channel, low noise, adjustable bandwidth sampler allowing multiple bandwidth settings for optimizing noise versus bandwidth demands.
- An amplified or non-amplified O/E converter.

- Support for internal RF switches in the signal path with a straight-through path and two hardware-filtered reference receiver paths between the O/E converter and the sampler.
- An average optical power meter.
- Integral clock recovery option with internal coaxial connection to the mainframe trigger, front panel clock and data output (not all have data).
- Communication with the mainframe for identification, control and calibration/compensation storage.

The “system response” depends on all of the components in the signal path from the front panel to the sampler. Bandwidth and reference receiver responses are calibrated at the factory with a sub-picosecond optical impulse applied to the front panel connector or with an optical heterodyne system. This insures that all components are included, but also means that components can not be replaced without performing calibration.

Compensation performs a DC transfer curve characterization for each bandwidth/reference receiver setting. The curve data is stored in the module’s EEPROM and used to generate a look-up table in the mainframe. This data corrects for linearity, gain and offset errors in the sampler.

Reference receivers can be created in any of the following ways:

- A hardware filter inserted between the O/E and the sampler and dominates the response.
- No filter is used, but the sampler’s bandwidth is adjusted.
- The O/E bandwidth is adjusted and dominates the response.

Information about the available bandwidth and reference receiver selections, and the method used to set the bandwidth for the optical modules starts on page 2-6.

The power monitor is a second measure of the photodiode current that is independent of the sampler signal path. Analog circuitry continuously senses the current flowing into the bias side of the photodiode. The signal is amplified by a programmable gain amplifier and input to an 8 bit AD converter. The AD converter and amplifier are controlled through the I²C interface. Compensation performs two functions in the power meter: First, two offset inputs are adjusted in the amplifier so that the signal stays in range for all of the gain settings. Next, offset is measured for all gain settings and stored so it can be subtracted from the raw measured current. Because the measurements are made through independent paths the power monitor is useful in debugging module/mainframe problems.

The main board of the module only provides power and control bits to the clock recovery board. A small fraction of the input signal is split off and applied to the

clock recovery components. The type of splitter for each module is shown in Table 2-1.

Table 2-1: Module optical/electrical split

Module	Optical Split	Electrical Split
C01	✓	
C02	✓	
C03		✓
C04	✓	
C07		✓
C07B		✓
C08		✓
C08B		✓
C08C		✓
C09	✓	
C11	✓	
C12		✓

The recovered clock is routed in coaxial cable through the rear connector of the module to the Optical Front End board in the mainframe. The Optical Front End board has a switch that selects which modules clock will be applied to the trigger. The control signal for that switch comes from the optical module.

80C01 Optical Sampling Module

The 80C01 module supports conformance testing of long wavelength (1100-1650 nm) signals at 622, 2488, and 9953 Mb/s as well as general purpose testing up to 20 GHz optical bandwidth. Bandwidth and reference receiver calibration is performed with a sub-picosecond optical impulse and a fourier transform method.

- OC12: The electrical sampler is adjusted to approximately 7.5 GHz (-3 dB) bandwidth and signal is routed through a hardware filter designed to result in the combined system having an OC12 (STM-4) Reference Receiver response.
- OC48: The electrical sampler is adjusted to 7.5 GHz (-3 dB) bandwidth and signal is routed through a hardware filter designed to result in the combined system having an OC48 (STM-16) Reference Receiver response. These adjustments must be made at the factory.
- OC192: The electrical sampler is adjusted to give the desired response, and signal is not routed through any filter (signal is sent through the straight-

through path). The sampler bandwidth and response is optimized during the calibration such that the combined system will have an OC192 (STM-64) Reference Receiver response.

- 12.5 GHz: The sampler bandwidth and response is set during the calibration such that the combined system will have an Optical Bandwidth (-6 dB) >12.5 GHz.
- 20 GHz: The sampler bandwidth and response is set during the calibration such that the combined system will have an Optical Bandwidth (-6 dB) >20 GHz.

For major functional circuit blocks refer to Figures 5-3 and 5-4 beginning on page 5-4.

80C02 Optical Sampling Module

The 80C02 module is optimized for testing of long-wavelength (1100-1650 nm) signals at (9.953 Gb/s) SONET OC-192 / SDH STM-64 standards. With its high optical bandwidth (>30 GHz) it is also well suited to general purpose high-performance optical component testing.

- OC192: The electrical sampler is adjusted to give the desired response, and signal is not routed through any filter (signal is sent through the straight-through path). The sampler bandwidth and response is optimized during the calibration such that the combined system will have an OC192 (STM-64) Reference Receiver response.
- 12.5 GHz: The sampler bandwidth and response is set during the calibration such that the combined system will have an Optical Bandwidth (-6 dB) >12.5 GHz.
- 20 GHz: The sampler bandwidth and response is set during the calibration such that the combined system will have an Optical Bandwidth (-6 dB) >20 GHz.
- 30 GHz: The sampler bandwidth and response is set during the calibration such that the combined system will have an Optical Bandwidth (-6 dB) >30 GHz.

For major functional circuit blocks refer to Figures 5-5 and 5-6 beginning on page 5-6.

80C03 Optical Sampling Module

The 80C03 module supports conformance testing of both short and long bandwidth (700-1650 nm) signals at 1.063, 1.250, and 2.488 Mb/s as well as general purpose testing with >2.3 GHz optical bandwidth. Its amplified optical to electrical converter design enables the user to examine very low-level optical signals.

- OC48: The electrical sampler is adjusted to approximately 12.5 GHz (-3 dB) bandwidth and signal is not routed through any filter (signal is sent through the straight-through path). The O/E converter is designed by the vendor to match the OC48 reference receiver response curve. The span adjustment provides limited adjustment of the frequency response. It is adjusted at the factory so that the combined system will have an OC48 (STM-64) Reference Receiver response. This mode is synonymous with the 2.3 GHz maximum bandwidth setting.
- FC1063: The electrical sampler is adjusted and O/E converter span voltage are the same values as in the OC48 mode. The signal is routed through a hardware filter designed to result in the combined system having an FC1063 (1.0625 Gb/s Fibre Channel) Reference Receiver response.
- GBE: The electrical sampler is adjusted and O/E converter span voltage are the same values as in the OC48 mode. The signal is routed through a hardware filter designed to result in the combined system having an GBE (1.25 Gb/s Gigabit Ethernet) Reference Receiver response.

The 80C03 module can be configured with clock recovery that supports Fibre Channel 1063 (1.063 Gb/s) and OC-48 / STM-16 (2.488 Gb/s) standards.

For major functional circuit blocks refer to Figure 5-7 and 5-8 beginning on page 5-8.

80C04 Optical Sampling Module

The 80C04 module is optimized for testing of long wavelength (1100-1650 nm) signals at either 9.953 Gb/s or 10.664 Gb/s. With its high optical bandwidth >28 GHz, it is also well suited to general-purpose, high-performance optical component testing.

- OC192 or 10.664 Gb/s: The electrical sampler is adjusted to give the desired response, and signal is not routed through any filter (signal is sent through the straight-through path). The sampler bandwidth and response is optimized during the calibration such that the combined system will have an OC192 (STM-64) or 10.66 Gb Reference Receiver response.
- 20 GHz: The sampler bandwidth and response is set during the calibration such that the combined system will have an Optical Bandwidth (-6 dB) >20 GHz.
- 30 GHz: The sampler bandwidth and response is set during the calibration such that the combined system will have an Optical Bandwidth (-6 dB) >28 GHz.

The 80C04 can be optionally configured with clock recovery (Opt. CR-1) that supports 9.953 Gb/s telecom standards.

For major functional circuit blocks refer to Figures 5-9 and 5-10 beginning on page 5-10.

80C05 Optical Sampling Module

The 80C05 module is designed to test long wavelength (1520–1580 nm) signals. This module is intended to be used as a test and measurement tool for high bandwidth telecommunications with its high optical bandwidth >40 GHz.

- OC192: There is one Reference Receiver setup selectable for 9.95328 Gb/s SONET/SDH standard.
- There is no clock recovery option available.

For major functional circuit blocks refer to Figure 5-11 on page 5-12.

80C06 Optical Sampling Module

The 80C06 module is designed to test long wavelength (1520–1580 nm) signals. This module is intended to be used as a test and measurement tool for high bandwidth telecommunications with its high optical bandwidth >55 GHz.

- 55 GHz: There is only a single bandwidth selection available, no Reference Receiver setups selectable.
- There is no clock recovery option available.

For major functional circuit blocks refer to Figure 5-12 on page 5-13.

80C07 Optical Sampling Module

The 80C07 module is designed to test both long and short wavelength (700–1650 nm) signals. This module is intended to be used as a test and measurement tool for high bandwidth telecommunications with its high optical bandwidth >2.3 GHz.

- Filtered rates are OC-3, OC-12; unfiltered rate is OC-48.
- There is clock recovery option available (155/622/2488 Multi-rate)

For major functional circuit blocks refer to Figures 5-13 and 5-14 on page 5-14.

80C07B Optical Sampling Module

The 80C07B module is designed to test both long and short wavelength (700–1650 nm) signals. This module is intended to be used as a test and measurement tool for high bandwidth telecommunications with its high optical bandwidth >2.3 GHz.

- Supported standards or data filtering rates include OC-3, OC-12, OC-48, ENET2500/2GBE, GBE, FC1063, FC2125, and Infiniband.
- Clock recovery options are available (155/622/1063/1250/2125/2488/2500/2666)

For major functional circuit blocks refer to Figures 5-13 and 5-14 on page 5-14.

80C08 Optical Sampling Module

The 80C08 module is designed to test both long and short wavelength (700–1650 nm) signals. This module is intended to be used as a test and measurement tool for high bandwidth telecommunications with its high optical bandwidth >9.0 GHz.

- 10.0 GHz: No filter is used and the sampler bandwidth is adjusted; the O/E bandwidth is adjusted and dominates the response (9.953/10.3125 Gb/s Multi-rate).
- There is clock recovery option available (9.953/10.3125 Gb/s Multi-rate).

For major functional circuit blocks refer to Figures 5-15 and 5-16 beginning on page 5-16.

80C08B Optical Sampling Module

The 80C08B module is designed to test both long and short wavelength (700–1650 nm) signals. This module is intended to be used as a test and measurement tool for high bandwidth telecommunications with its high optical bandwidth >9.5 GHz.

- 10.0 GHz: No filter is used and the sampler bandwidth is adjusted; the O/E bandwidth is adjusted and dominates the response (9.953/10.3125 Gb/s Multi-rate).
- Clock recovery options are available (9.953/10.3125/10.51875 Gb/s Multi-rate).

For major functional circuit blocks refer to Figures 5-15 and 5-16 beginning on page 5-16.

80C08C Optical Sampling Module

The 80C08C module is designed to test both long and short wavelength (700–1650 nm) signals. This module is intended to be used as a test and measurement tool for high bandwidth telecommunications with its high optical bandwidth >10 GHz.

- 10.0 GHz: No filter is used and the sampler bandwidth is adjusted; the O/E bandwidth is adjusted and dominates the response (9.953/10.3125/10.518/10.66/10.709/11.1 Gb/s).
- Clock recovery options are available (9.953/10.3125/10.518 Gb/s and Continuous-rate from 9.8 Gb/s to 12.6 Gb/s).

For major functional circuit blocks refer to Figures 5-15 and 5-16 beginning on page 5-16.

80C09 Optical Sampling Module

The 80C09 module is designed to test long wavelength (1100–1650 nm) signals. This module is intended to be used as a test and measurement tool for high bandwidth telecommunications with its high optical bandwidth >30 GHz.

- Supported standards or data filtering rates include OC-192 and FEC10.709.
- Clock recovery options are available (OC-192 and FEC10.709)

For major functional circuit blocks refer to Figures 5-17 and 5-18 beginning on page 5-18.

80C10 Optical Sampling Module

The 80C10 module is designed to test long wavelength (1310 and 1550 nm) signals. This module is intended to be used as a test and measurement tool for high bandwidth telecommunications with its high optical bandwidth >65 GHz.

- Supported standards or data filtering rates include OC-768 and FEC43.02 (G.709).
- 30 GHz: The sampler bandwidth and response is set during the calibration such that the combined system will have an Optical Bandwidth (-6 dB) >30 GHz.
- 65 GHz: The sampler bandwidth and response is set during the calibration such that the combined system will have an Optical Bandwidth (-6 dB) >65 GHz.
- There is no clock recovery option available.

For major functional circuit blocks refer to Figure 5-19 on page 5-20.

80C11 Optical Sampling Module

The 80C11 module is designed to test long wavelength (1100–1650 nm) signals. This module is intended to be used as a test and measurement tool for high bandwidth telecommunications with its high optical bandwidth >20 GHz.

- Supported standards or data filtering rates include 9.953/10.31/10.518/10.66/10.71/11.1 Gb/s.
- Clock recovery options are available (9.953/10.66/10.71 Gb/s and Continuous-rate from 9.8 Gb/s to 12.6 Gb/s)

For major functional circuit blocks refer to Figures 5-20, 5-21, 5-22, and 5-23 beginning on page 5-21.

80C12 Optical Sampling Module

The 80C12 module is designed to test both long and short wavelength (700–1650 nm) signals. This module is intended to be used as a test and

measurement tool for high bandwidth telecommunications with its high optical bandwidth >10 GHz.

- There are three Reference Receiver filters selectable that are customer specified from the following list of five rates: 1FC (FC1063) for 1.0625Gb/s FibreChannel, 2FC (FC2125) for 2.125Gb/s FibreChannel, 10GBase-X4 for 3.125Gb/s, VSR-5 for 3.31776 Gb/s, and 4FC (FC4250) for 4.25 Gb/s Fibre Channel. A filterless, full-bandwidth setting (9 GHz) is also available.
- In addition, this module offers the option to support 10 Gb/s optical standards as well. This option is mutually exclusive with the sub-10Gb/s filter options. The standard reference receiver filter rates offered with the Option 10G are SONET/SDH OC-192/STM-64, 10GBase-W, 10 Gb Ethernet (9.95338 Gb/s), 10GBase-R (10.3125 Gb/s), 10G Fibre Channel (10.51875 Gb/s), G.975 FEC (10.66 Gb/s), G.709 FEC (10.71 Gb/s), 10GBE FEC (11.0957 Gb/s). These filter settings require no hardware filters.
- An electrical clock recovery output signal is provided that can be routed to the Tektronix 80A05 Electrical Clock Recovery module for clock recovery.

For major functional circuit blocks refer to Figure 5-24 on page 5-25.

80A01 Trigger Prescale Preamplifier Module

The 80A01 module is designed to increase the sensitivity of the prescale trigger input of the CSA8000/TDS8000 instruments to $\leq 200 \text{ mV}_{\text{pk-pk}}$.

The major function block of the module is a high sensitivity, high gain RF amplifier. The input and output to this amplifier are routed to two identical SMA, female connectors, labelled Input and Output at the module front panel.

The module receives power from the main instrument through a single connector at the rear of the module. The power LED indicates the module is receiving power through the interface connector.

For major functional circuit blocks refer to Figure 5-25 on page 5-26.

80A02 EOS/ESD Protection Module

The 80A02 EOS/ESD (Electrical Over Stress/Electro-Static Discharge) protection module provides static electricity damage protection to vulnerable sampling head input stages and/or other sensitive elements.

The 80A02 works with any CSA/TDS8000 series instruments or with 11K series sampling instruments (11800 or CSA803 series instruments).

The 80A02 EOS/ESD module has a 26 GHz bandwidth, making it possible to provide static protection to a sensitive single input channel of a sampling oscilloscope with very minimal speed degradation.

The 80A02 EOS/ESD module is designed to work with either the Tektronix P8018 probe for manual test station static protection as well as automated test stations.

For major functional circuit blocks refer to Figure 5-26 on page 5-27.

80A05 Electrical Clock Recovery Module

The electrical clock recovery module is capable of performing clock recovery on the input signal (signal input must meet data rate and format requirements), and provides this signal as a trigger source to the CSA/TDS8000 series instruments.

Front panel connectors provide a replica of the recovered clock signal.

The module uses one of two separate clock recovery circuits dependant on the specified data rate. The single-ended or complementary input signals are split with a 1:2 divider and routed to the two circuits.

The low bandwidth circuit recovers clock and data from input data in the 50 Mb/s to 2.7 Gb/s range. The recovered clock from this circuit is routed directly to the front panel and internal trigger.

The high bandwidth circuit recovers clock and data from input data in the 2.7 Gb/s to 12.6 Gb/s range. The recovered clock to the front panel and internal trigger signals are always clock/16.

With option 10G, the 10G recovered clock is also routed to the front panel.

There is one front panel indicator LED - Clock Recovery Enable. It indicates the clock recovery circuitry is on and programmed to the requested bit rate.

For major functional circuit blocks refer to Figure 5-27 on page 5-28.

80A06 PatternSync Trigger Module

The 80A06 PatternSync Trigger Module is designed to provide a frame trigger for the CSA8000 and TDS8000 series instruments. The instrument must be using the Windows 2000 Operating System and product software version 2.4 or greater.

The frame trigger is derived by counting a programmed amount of user supplied clock cycles and generating a pulse at the completion of the count. This pulse is then routed externally to the main instrument's external trigger direct input.

An additional buffered copy of the input clock is output to the front panel for connection to additional equipment such as an 82A04 Phase Reference Module.

The 80A06 consumes a small slot or may be operated on a SlotSaver cable connected to the main instrument's probe power connector.

Pattern triggering works for clocks in the range of 150 MHz to 12.75 GHz.

For major functional circuit blocks refer to Figure 5-28 on page 5-29.

82A04 Phase Reference Module

The 82A04 Phase Reference Module is designed to decrease horizontal position uncertainty with data signals, when a reference clock signal synchronized to the data signal, is available. It consumes a small slot, and displaces operation of both channels in that slot.

The Phase Correction modes available are free run, where the module provides unit circle location information for the phase of the data sample, and triggered, where the module, in conjunction with the trigger signal, provides both base positioning, and refined positioning, for the data sample.

The input is precision 1.85 mm. Phase correction works over the range of 2.5 GHz - 25 GHz (82A04), or 2.5 GHz - 60 GHz (82A04-60G). The LED indicates the module is being utilized for phase correction.

For major functional circuit blocks refer to Figure 5-29 on page 5-30.



Adjustment Procedures

Adjustment Procedures

This chapter contains an adjustment procedure for your instrument. The purpose of this procedure is to return the instrument conformance to its specifications.

Adjustment Interval

The voltage and timing references inside the instrument are very stable over time and should not need routine adjustment. The only time you should perform the *Adjustment Procedures* is if the instrument fails any of the Mainframe performance verification checks starting on page NO TAG.

Adjustment Environment

The instrument must be adjusted in a 20 °C to 30 °C ambient temperature environment. The instrument and signal source must warm up at least 20 minutes in this environment before you begin the adjustment procedure.

Adjustment After Repair

After removal and replacement of a module due to electrical failure, you must either perform the adjustment procedure or not, depending on the module replaced. See Table 3-1.

Table 3-1: Adjustments required for module replaced

Module replaced	Adjustment required
Front panel assembly	No
Acquisition board	Yes
Processor board	No
NLX processor assembly	No
Display panel or display system	No
Power supply	No
Interconnect boards	No
Fans	No

Required Equipment

The adjustment procedure requires the specific test equipment and materials listed in Table 3-2.

Table 3-2: Required equipment and materials

Category	Specific equipment required	Quantity
Signal source	Signal generator 50 MHz to 1 GHz, ≤ 1 ppm frequency accuracy	1 ea
Meter	Digital Multimeter, with 6.5 plus digits	1 ea
Instrument controller (only one of these configurations required)	PC-compatible computer with National Instruments GPIB Controller card and software, running Windows 95/98 or NT	1 ea
	National Instruments USB GPIB Controller card for Windows 98 and National Instruments NI-488.2 for Windows software (to install in the instrument) ¹	1 ea
Divider	Power, 50 Ω , SMA "T". male Tektronix 015-0565-00	1 ea
Adapter	SMA "T", male to 2 SMA female Tektronix part number 015-1016-00	1 ea
Adapter	SMA male to BNC female, Tektronix part number 015-0554-00	1 ea
Adapter	BNC to dual banana plug, Tektronix part number 103-0095-00	1 ea
Coaxial cables	50 Ω , male-to-male SMA connectors	3 ea
GPIB cables	GPIB cable, 1 m minimum length, Tektronix part number 002-0991-01	1 ea

¹ Depending on other USB devices attached to the instrument, a USB hub may also be required. Consult your National Instruments documentation for more information.

Instrumentation Setup

Set the National Instruments GPIB Interface command software to allow GPIB communications between the PC controller and CSA8000/TDS8000, device under test (DUT).

Before you can execute the adjustment program, you need to set up and configure the instrumentation. Make connections according to the following diagrams. See Figure 3-1.

To perform this procedure you must have the specific equipment listed in Table 3-2.

Main Instrument Adjustments

Once the instrumentation is connected and GPIB configured, allow the instrumentation to warm up for at least 20 minutes before starting the *DC Calibrator Adjust procedures*.

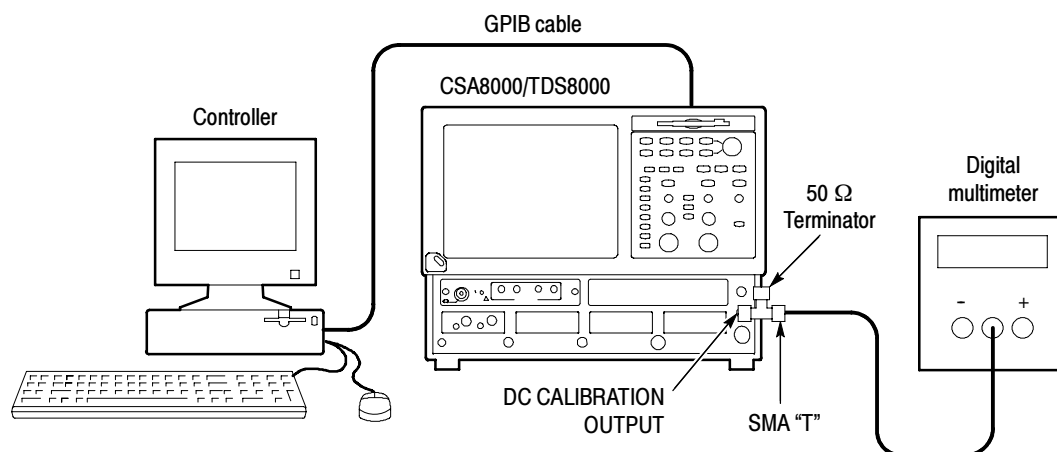

Figure 3-1: Adjustment setup using the DMM

DC Calibrator Adjust

Connect the instrument to a DMM as shown in Figure 3-1.

1. Run the compensation routine, described in *Brief Procedures* section on page NO TAG.
2. Enter the following GPIB command to verify communication between the controller and DUT.
*IDN?
Should respond with Tektronix and Firmware Version.
3. Enter the following GPIB command to turn the instrument's cal constant protection off:
SYST:PROT OFF
4. Enter the following GPIB command to set the instrument's DC calibrator offset cal constant to 0:
CALCOMP:DOUBLE "DcCalOffsetAdj",0.0
5. Wait 8 seconds then enter the following GPIB command to set the instrument's DC calibrator Lsb cal constant to 1.0:
CALCOMP:DOUBLE "DcCalLsbAdj",1.0

6. Wait 8 seconds then enter the following GPIB command to set the instrument's DC calibrator output to 0 Volts:
CALIBRATE:DCCALIBRATOR 0.0
Record DMM reading.
7. Enter the following GPIB command to set the instrument's DC calibrator offset cal constant to $-1 * \text{DMM reading}$:
CALCOMP:DOUBLE "DcCalOffsetAdj",(-1.0 * the DMM reading)

Example: CALCOMP:DOUBLE "DcCalOffsetAdj", 3.2e-4
8. Enter the following GPIB command to set the instrument's calibrator to 1.0 V:
CALIBRATE:DCCALIBRATOR 1.0
Record the DMM reading (*reading1*).
9. Enter the following GPIB command to set the instrument's calibrator to -1.0 V:
CALIBRATE:DCCALIBRATOR -1.0
Record the DMM reading (*reading2*).
Calculate cal constant as follows:
$$\frac{(-1.0 * \text{Reading2} + \text{Reading1})}{2}$$
10. Enter the following GPIB command to set the instrument's calibrator Lsb cal constant:
CALCOMP:DOUBLE "DcCalLsbAdj",calculated result from Step 9.
11. Wait 8 seconds then enter the following GPIB command to save the DC adjustments as follows:
CAL:SAVE:FACT:MAI
12. Enter the following GPIB command to turn the instrument's cal constant protection on:
SYST:PROT ON

**DC Calibrator Adjust
Verification**

To verify that the DC calibration adjustment was successful complete the following procedures:

1. Set the instrument's DC calibrator to -1.0 V and verify as follows:
CALIBRATE:DCCALIBRATOR -1.0
2. Verify that the DMM reads $-1.0 \text{ V} \pm 1 \text{ mV}$
3. Set the instrument's DC calibrator to 1.0 V and verify as follows:
CALIBRATE:DCCALIBRATOR 1.0
4. Verify that the DMM reads $1.0 \text{ V} \pm 1 \text{ mV}$

5. Set the instrument's DC calibrator to 0.0 V and verify as follows:
CALIBRATE:DCCALIBRATOR 0.0
6. Verify that the DMM reads 0.0 V \pm 0.1 mV

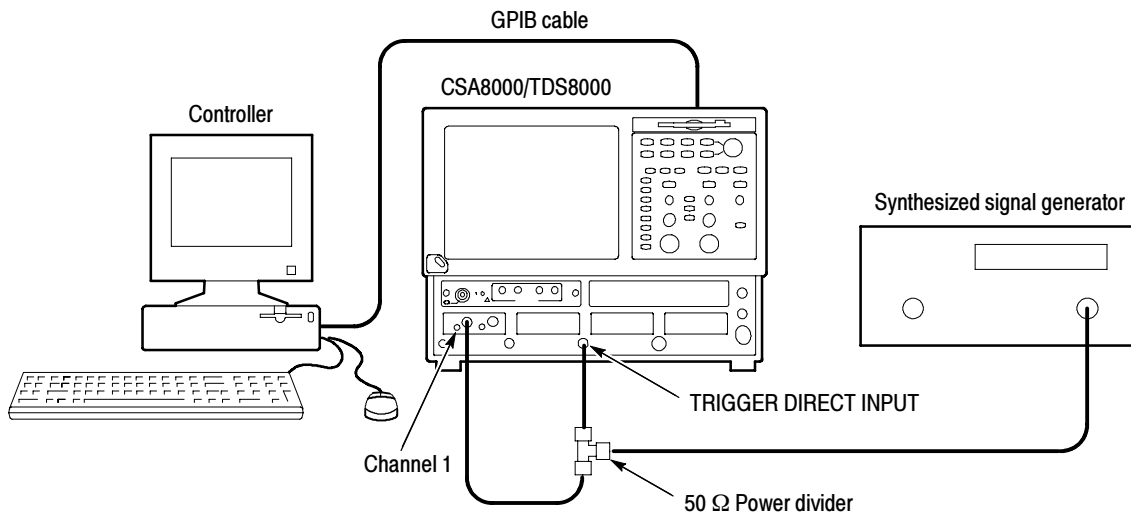

Figure 3-2: Adjustment setup using the signal generator

Internal 10 MHz Adjust Setup

Connect the instrument to a signal generator as shown in Figure 3-2.

Set the signal generator as follows:

- Frequency to 1 GHz
- Amplitude to 1.0 V peak to peak
- Output to on

Preset the CSA8000/TDS8000 controls:

NOTE. CSA8000/TDS8000 settings; Acquisition, Horizontal, Measurement, Trigger, or Vertical menus are located in the Setups dialog, which can be popped up by selecting the Setup Menu.

- Select C1 in the Waveform Selector.
- Acquisition menu, Acquisition to, Average, 64 samples.
- Horizontal menu, Timebase, Scale to 250 ps/division.
- Horizontal menu, All Timebases Mode, Lock to Int 10MHz.
- Measurement menu, Select Meas, Timing, + Cross.
- Measurement menu, select Statistics.

1. Enter the following GPIB command to turn the instrument's cal constant protection off:
SYST:PROT OFF
2. Set the calibration value to default by sending the following GPIB command:
CALCOMP:DOUBLE "Internal10MHzRefFreq",10e6
3. Click Run/Stop (button should be green).
4. Measurement menu, click Show Stats.
5. Record *target value* = (*Mean value* +1 μ s); where *Mean* is from the Statistics window.
6. Horizontal menu, Timebase, Position, enter *target value* recorded in step 5.
7. Click Run/Stop (button should be gray).
8. Measurement menu, click Clear Stats.
9. Click Run/Stop (button should be green), wait 8 seconds then click Run/Stop again (button should be gray).
10. Using the present *Mean* value from the Statistics window, and the *target value* calculated in step 5., Calculate the error and the new cal constant:
$$Error = (mean - target\ value) / 1\ \mu s$$
$$New\ Cal\ Const = Error * 10e6 + 10e6$$
11. Input the new calibration constant into the instrument by sending the following GPIB command:
CALCOMP:DOUBLE "Internal10MHzRefFreq", *New Cal Const* where *New Cal Const* is from Step 10.
12. Wait 8 seconds then save the mainframe factory calibration constants by entering the following GPIB commands:
CAL:SAVE:FACT:MAI
13. Update the mainframe calibration time/date/temperature stamp by entering the following GPIB command:
CAL:UPDATEINFO:MAI
14. Enter the following GPIB command to turn the instrument's cal constant protection on:
SYST:PROT ON

End of Procedure



Maintenance

Maintenance

This section contains the information needed to do periodic and corrective maintenance on the Mainframe, Sampling Heads and Optical modules. The following subsections are included:

- *Preparation.* Introduction plus general information on preventing damage to internal modules when doing maintenance.
- *Inspection and Cleaning.* Information and procedures for inspecting the instrument and cleaning its external and internal modules.
- *Removal and Installation Procedures.* Procedures for the removal of defective modules and replacement of new or repaired modules. Also included is a procedure for disassembly of the instrument for cleaning.
- *Troubleshooting.* Information for isolating and troubleshooting failed modules. Included are instructions for operating the instrument's internal diagnostic routines and troubleshooting trees. Most of the trees make use of these internal diagnostic routines to speed fault isolation to a module.

Preventing ESD

Before servicing this product, read the *Safety Summary* and *Introduction* at the front of the manual and the ESD information below.



CAUTION. *Static discharge can damage any semiconductor component in this instrument.*

When performing any service which requires internal access to the instrument, adhere to the following precautions to avoid damaging internal modules and their components due to electrostatic discharge (ESD).

1. Minimize handling of static-sensitive circuit boards and components.
2. Transport and store static-sensitive modules in their static protected containers or on a metal rail. Label any package that contains static-sensitive boards.
3. Discharge the static voltage from your body by wearing a grounded antistatic wrist strap while handling these modules. Do service of static-sensitive modules only at a static-free work station.
4. Nothing capable of generating or holding a static charge should be allowed on the work station surface.

5. Handle circuit boards by the edges when possible.
6. Do not slide the circuit boards over any surface.
7. Avoid handling circuit boards in areas that have a floor or work-surface covering capable of generating a static charge.

Inspection and Cleaning

Inspection and Cleaning describes how to inspect for dirt and damage. It also describes how to clean the exterior and interior of the instrument. Inspection and cleaning are done as preventive maintenance. Preventive maintenance, when done regularly, may prevent instrument malfunction and enhance its reliability.

Preventive maintenance consists of visually inspecting and cleaning the instrument and using general care when operating it.

How often to do maintenance depends on the severity of the environment in which the instrument is used. A proper time to perform preventive maintenance is just before instrument adjustment.

General Care

The cabinet helps keep dust out of the instrument and should normally be in place when operating the instrument.



WARNING. *Before performing any procedure that follows, power down the instrument and disconnect it from line voltage.*

Flat Panel Display Cleaning

The portable mainframe display is a soft plastic display and must be treated with care during cleaning.



CAUTION. *Improper cleaning agents or methods can damage the flat panel display.*

Avoid using abrasive cleaners or commercial glass cleaners to clean the display surface.

Avoid spraying liquids directly on the display surface.

Avoid scrubbing the display with excessive force.

Clean the flat panel display surface by gently rubbing the display with a clean-room wipe (such as Wypall Medium Duty Wipes, #05701, available from Kimberly-Clark Corporation).

If the display is very dirty, moisten the wipe with distilled water or a 75% isopropyl alcohol solution and gently rub the display surface. Avoid using excess force or you may damage the plastic display surface.



CAUTION. To prevent getting moisture inside the instrument during external cleaning, use only enough liquid to dampen the cloth or applicator.

Exterior Use the following guidelines and methods to inspect and clean the outside of the instrument.

Inspection — Exterior. Inspect the outside of the instrument for damage, wear, and missing parts, using Table 4-1 as a guide. Immediately repair defects that could cause personal injury or lead to further damage to the instrument.

Table 4-1: External inspection check list

Item	Inspect for	Repair action
Cabinet, front panel, and cover	Cracks, scratches, deformations, damaged hardware.	Repair or replace defective module.
Front-panel knobs	Missing, damaged, or loose knobs.	Repair or replace missing or defective knobs.
Connectors	Broken shells, cracked insulation, and deformed contacts. Dirt in connectors.	Repair or replace defective modules. Clear or wash out dirt.
80C0X male fiber connections	Lint or dust on all male fiber connections.	Clean all male fiber connections with a lint-free cleaning cloth.
Carrying handle, and cabinet feet.	Correct operation.	Repair or replace defective module.
Accessories	Missing items or parts of items, bent pins, broken or frayed cables, and damaged connectors.	Repair or replace damaged or missing items, frayed cables, and defective modules.

Cleaning — Exterior. Clean the exterior surfaces of the chassis with a dry lint-free cloth or a soft-bristle brush. If any dirt remains, use a cloth or swab dipped in a 75% isopropyl alcohol solution. Use a swab to clean narrow spaces around controls and connectors. Do not use abrasive compounds on any part of the chassis that may damage the chassis.

Clean the On/Standby switch using a dampened cleaning towel. Do not spray or wet the switch directly.



CAUTION. Avoid the use of chemical cleaning agents which might damage the plastics used in this instrument. Use only deionized water when cleaning the menu buttons or front-panel buttons. Use a 75% isopropyl alcohol solution as a cleaner and rinse with deionized water. Before using any other type of cleaner, consult your Tektronix Service Center or representative.

Interior

Use the following guidelines and methods to inspect and clean the inside of the instrument.

Inspection — Interior. To access the inside of the instrument for inspection and cleaning, refer to the *Removal and Installation Procedures* in this section.

Inspect the internal portions of the instrument for damage and wear, using Table 4-2 as a guide. Defects found should be repaired immediately.

If any circuit board is repaired or replaced, check Table 3-1 on page 3-1, in Chapter 5 to see if it is necessary to adjust the instrument.



CAUTION. To prevent damage from electrical arcing, ensure that circuit boards and components are dry before applying power to the instrument.

Table 4-2: Internal inspection check list

Item	Inspect for	Repair action
Circuit boards	Loose, broken, or corroded solder connections. Burned circuit boards. Burned, broken, or cracked circuit-run plating.	Remove and replace damaged circuit board.
Resistors	Burned, cracked, broken, blistered condition.	Remove and replace damaged circuit board.
Solder connections	Cold solder or rosin joints.	Resolder joint and clean with isopropyl alcohol.
Capacitors	Damaged or leaking cases. Corroded solder on leads or terminals.	Remove and replace damaged circuit board.

Table 4-2: Internal inspection check list (cont.)

Item	Inspect for	Repair action
Semiconductors	Loosely inserted in sockets. Distorted pins.	Firmly seat loose semiconductors. Remove devices that have distorted pins. Carefully straighten pins (as required to fit the socket), using long-nose pliers, and reinsert firmly. Ensure that straightening action does not crack pins, causing them to break off.
Wiring and cables	Loose plugs or connectors. Burned, broken, or frayed wiring.	Firmly seat connectors. Repair or replace modules with defective wires or cables.
Chassis	Dents, deformations, and damaged hardware.	Straighten, repair, or replace defective hardware.

Cleaning Procedure — Interior. To clean the instrument interior, do the following steps:

1. Blow off dust with dry, low-pressure, deionized air (approximately 9 psi).
2. Remove any remaining dust with a lint-free cloth dampened in isopropyl alcohol (75% solution) and rinse with warm deionized water. (A cotton-tipped applicator is useful for cleaning in narrow spaces and on circuit boards.)

STOP. If, after doing steps 1 and 2, a module is clean upon inspection, skip the remaining steps.

3. If steps 1 and 2 do not remove all the dust or dirt, the instrument may be spray washed using a solution of 75% isopropyl alcohol by doing steps 4 through 8.
4. Gain access to the parts to be cleaned by removing easily accessible shields and panels (see *Removal and Installation Procedures*).
5. Spray wash dirty parts with the isopropyl alcohol and wait 60 seconds for the majority of the alcohol to evaporate.
6. Use hot (120 °F to 140 °F) deionized water to thoroughly rinse them.
7. Dry all parts with low-pressure, deionized air.
8. Dry all components and assemblies in an oven or drying compartment using low-temperature (125 °F to 150 °F) circulating air.

Removal and Installation Procedures

This subsection contains procedures for removal and installation of all mechanical and electrical modules.

Preparation



WARNING. *Before doing this or any other procedure in this manual, read the Safety Summary found at the beginning of this manual. Also, to prevent possible injury to service personnel or damage to this instrument's components, read Installation in Chapter 2, and Preventing ESD in this section.*

This subsection contains the following items:

- Preparatory information that you need to properly do the procedures that follow.
- A list of tools required to remove and disassemble all modules.
- Procedures for removal and reinstallation of the electrical and mechanical modules.
- A disassembly procedure for removal of all the major modules from the instrument at one time and for reassembly of those modules into the instrument. Instructions for doing the actual cleaning are found under *Inspection and Cleaning* at the beginning of this section.
- Module disassembly procedures.



WARNING. *Before doing any procedure in this subsection, disconnect the power cord from the line voltage source. Failure to do so could cause serious injury or death.*

NOTE. *Read Equipment Required for a list of the tools needed to remove and install modules in this instrument. See Table 4-3, page 4-8.*

Read the cleaning procedure before disassembling the instrument for cleaning.

Equipment Required. Most modules in this instrument can be removed with a screwdriver handle mounted with a size T-15, Torx® screwdriver tip. *Use this tool whenever a procedure step instructs you to remove or install a screw unless a different size screwdriver is specified in that step.* All equipment required to remove and reinstall each module is listed in the first step of its procedure.

Table 4-3: Tools required for module removal

Item No.	Name	Description	Part number
1	Screwdriver handle	Accepts Torx®-driver bits	General Tool: 620-440
2	Screwdriver handle, extended length, 10.5 to 12 inches	Accepts Torx®-driver bits and $\frac{3}{16}$ socket tip. Used for removing the T-10 screws and $\frac{3}{16}$ inch hex posts from the electrical and optical module slots.	Standard tool or Xcelite 99X10V N/S#48706
3	T-10 Torx tip	Used for removing the electrical or optical module chassis. Torx®-driver bit for T-10 size screw heads.	General Tool: 640-235
4	T-15 Torx tip	Used for removing most the instrument's screws. Torx®-driver bit for T-15 size screw heads.	General Tool: 640-247
5	T-20 Torx tip	Used for removing the handle hardware. Torx®-driver bit for T-20 size screw heads.	General Tool: 640-250
6	$\frac{3}{16}$ inch socket tip	Used for removing the $\frac{3}{16}$ inch hex posts from the electrical and optical module slots.	Standard tool
7	$\frac{1}{8}$ inch flat-bladed screwdriver	Screwdriver for unlocking cable connectors.	Standard tool
8	#0 phillips screwdriver	Screwdriver for removing small phillips screws, CD, floppy & hard drive.	Standard tool
9	Angle-Tip Tweezers	Used to remove front panel knobs	Standard tool
10	$\frac{3}{16}$ inch open-end wrench	Used to remove the rear panel nut posts.	Standard tool
11	$\frac{5}{16}$ inch open-end wrench	Used to remove the rear panel nut posts.	Standard tool
12	Coaxial cable connector tool	Used to remove coaxial connectors from d-subminiature connector housings.	Amp: 58095-1

Procedures for External Modules

The following procedures are found here and are listed in order presented.

- Front Panel Knobs
- Trim (all)
- Bottom cover
- Left and Right covers
- Line Fuse and Line Cord

Front-Panel Knobs

1. *Assemble equipment and locate modules to be removed:* Use an angled-tip tweezers (Item 9) and locate the the front panel see Figure 4-2 on page 4-11.
2. *Orient the instrument:* Set the instrument so its bottom is down on the work surface and its front is facing you.
3. *Remove the knob(s):* Grasp any knob you want to remove and pull it straight out from the front panel about a $\frac{1}{4}$ inch to create some clearance between the base of the knob and the front panel. Insert the tweezers between the knob and front panel and use them to remove the knob. See Figure 4-1.
4. *Reinstallation:* To reinstall, align knob to shaft and push it in until it snaps.



CAUTION. To prevent damage to the encoders located onto the circuit board, apply pressure to the backs of the encoders while pushing the knob on the shaft.

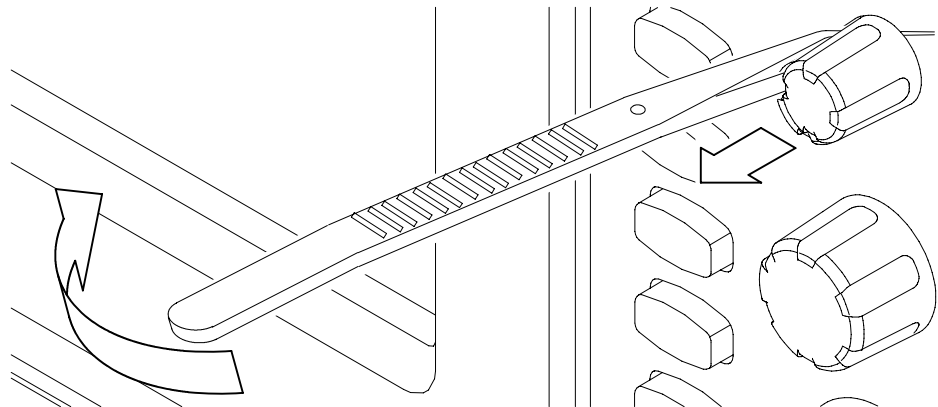

Figure 4-1: Knob removal

Trim and Carrying Handle

1. *Locate module to be removed:* Locate the Trim in the locator diagram, See Figure 4-7, page 4-18.
2. *Remove the front panel trim:* Use Figure 4-2, page 4-11, as a guide.
 - a. Grasp the trim ring by its top edge and pull toward you to detach the three plastic snaps. (Alternatively, you can use a flat-bladed screwdriver or other small prying tool to help you detach the snaps.)
 - b. Swing the bottom of the ring upward and off the front panel.
3. *Remove the acquisition trim:* Use Figure 4-2, page 4-11 as a guide.
 - a. Remove the six T-15 Torxdrive screws that secure the acquisition trim to the instrument.
 - b. Remove the knobs from the electrical and optical ejector levers. Grasp the knobs with your fingers and pull straight out.
 - c. Remove the acquisition trim from the instrument.
4. *Remove the top cover trim:* Use Figure 4-2, page 4-11 as a guide.
 - a. Remove the accessory pouch; it snaps off.
 - b. Remove the four T-15 Torxdrive screws that secure the top cover trim to the instrument. The T-15 Torxdrive screws also secure the snap studs to the top cover.
 - c. Remove the top cover trim from the instrument.
5. *Remove the carrying handle and the right/left side trim panels:* Use Figure 4-2, page 4-11 as a guide.
 - a. Remove the two T-20 Torxdrive screws that secure the handle to the instrument. Remove the handle from the instrument.



CAUTION. *Over-tightening the handle screws may cause the handle to break off from the cabinet. When reinstalling the screws, use a torque wrench to tighten the screws to 8-10 in.lb.*

- b. Slide the side trim panels towards the rear of the instrument allowing the tabs to clear the cover openings, then pull out to remove the panels from the instrument.
6. *Reinstallation:* Do in reverse steps 2 through 5 to reinstall the appropriate trim.

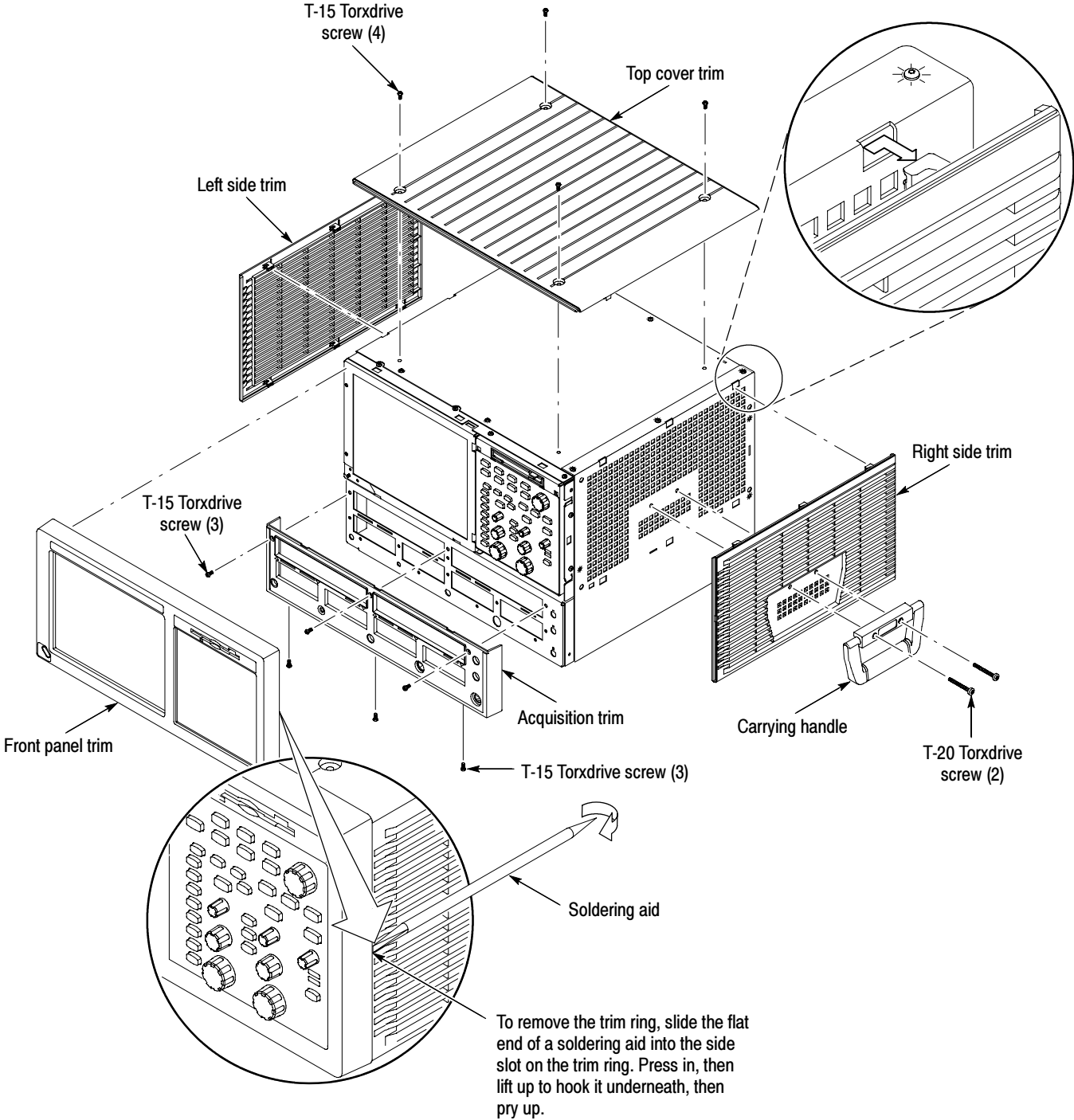

Figure 4-2: Trim removal

Bottom Cover 1. Remove the bottom cover: See Figure 4-3, page 4-12.

2. *Orient the instrument:* Set the instrument so its top is down on the work surface and its bottom is facing you.
 - a. Remove the five T-15 Torxdrive screws that secure the bottom cover to the instrument.
 - b. Remove the bottom cover from the instrument.
3. *Reinstallation:* Do in reverse steps a and b to reinstall the cabinet feet.

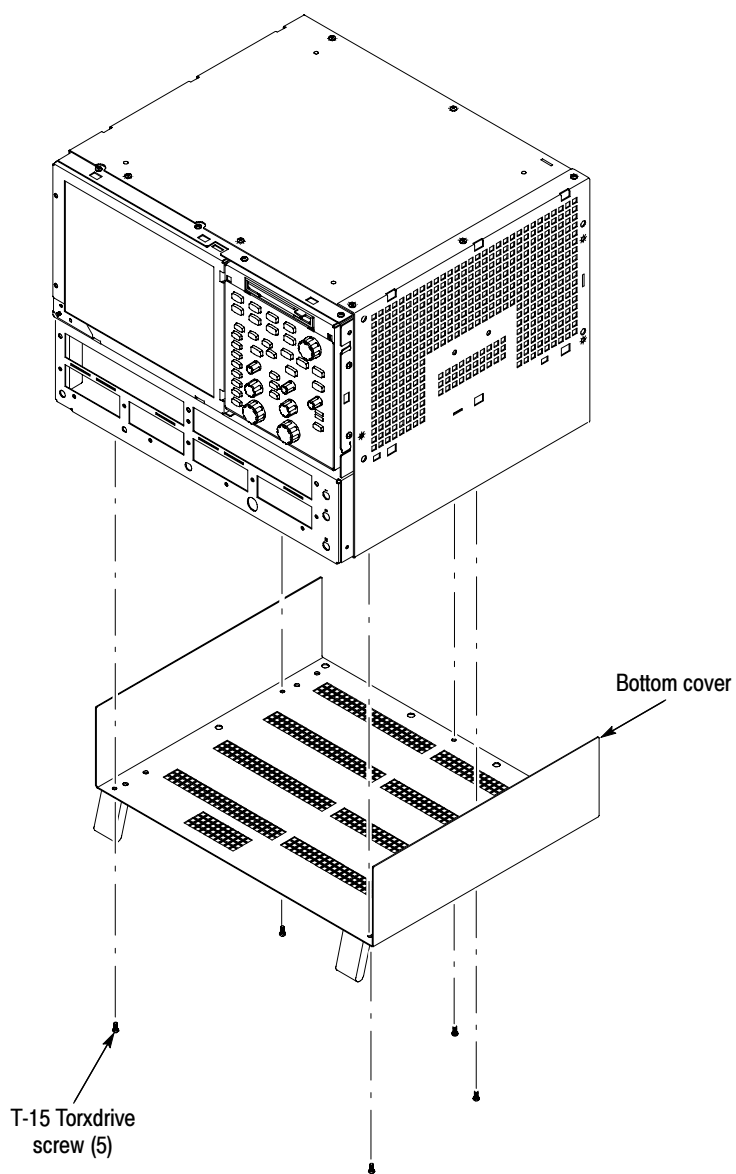

Figure 4-3: Bottom cover removal

- Covers**
1. *Remove the left and right covers:* See Figures 4-4 and 4-5, pages 4-14 and 4-15.
 - Trim (all)
 - Bottom cover
 2. *Orient the instrument:* Set the instrument so its rear is on the work surface and the front of the instrument facing the technician.

NOTE. *All mounting screw holes are indicated by a star etched around the mounting hole.*

- a. Remove the thirteen T-15 Torxdrive screws that secure the covers to the top and both sides of the chassis.
- b. Remove the nine T-15 Torxdrive screws that secure the covers to the bottom of the chassis.
- c. Pull the bottom-right cover down and slide to the right to remove from the instrument. Pull the top-left cover upward and slide to the left to remove from the instrument.



CAUTION. *Take care not to bind or snag the covers on the instrument's internal cabling as you remove or install.*

3. *Reinstallation:* Do in reverse steps a through c to reinstall the cabinet.

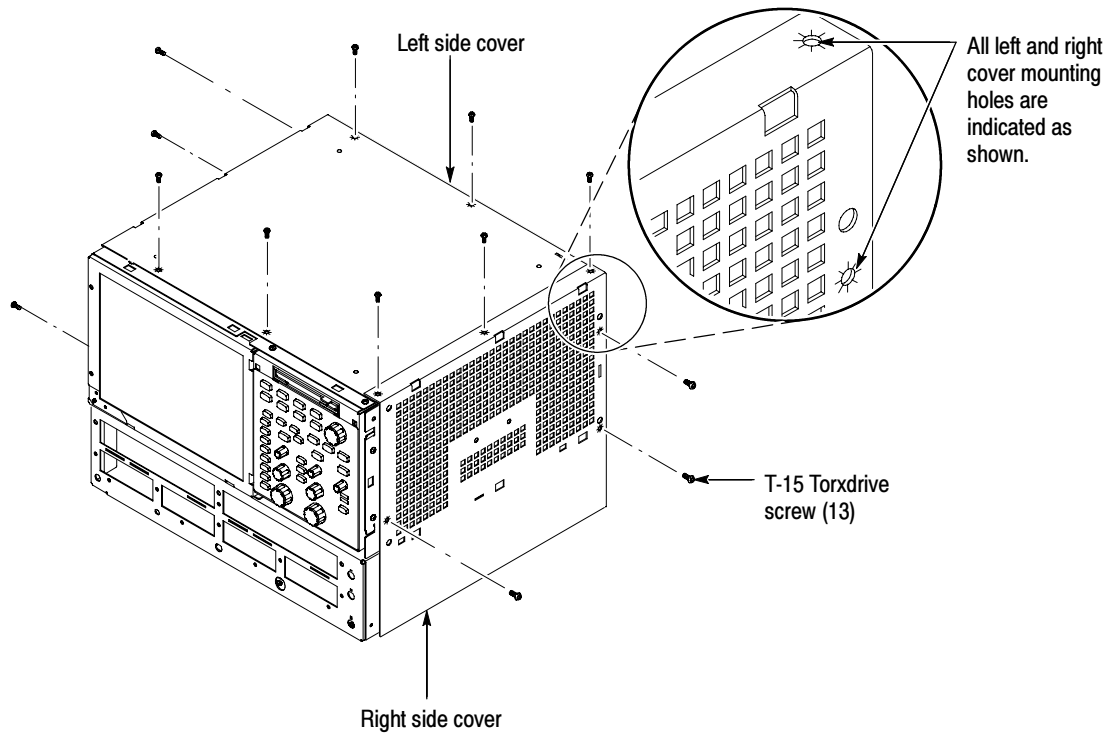

Figure 4-4: Cover removal

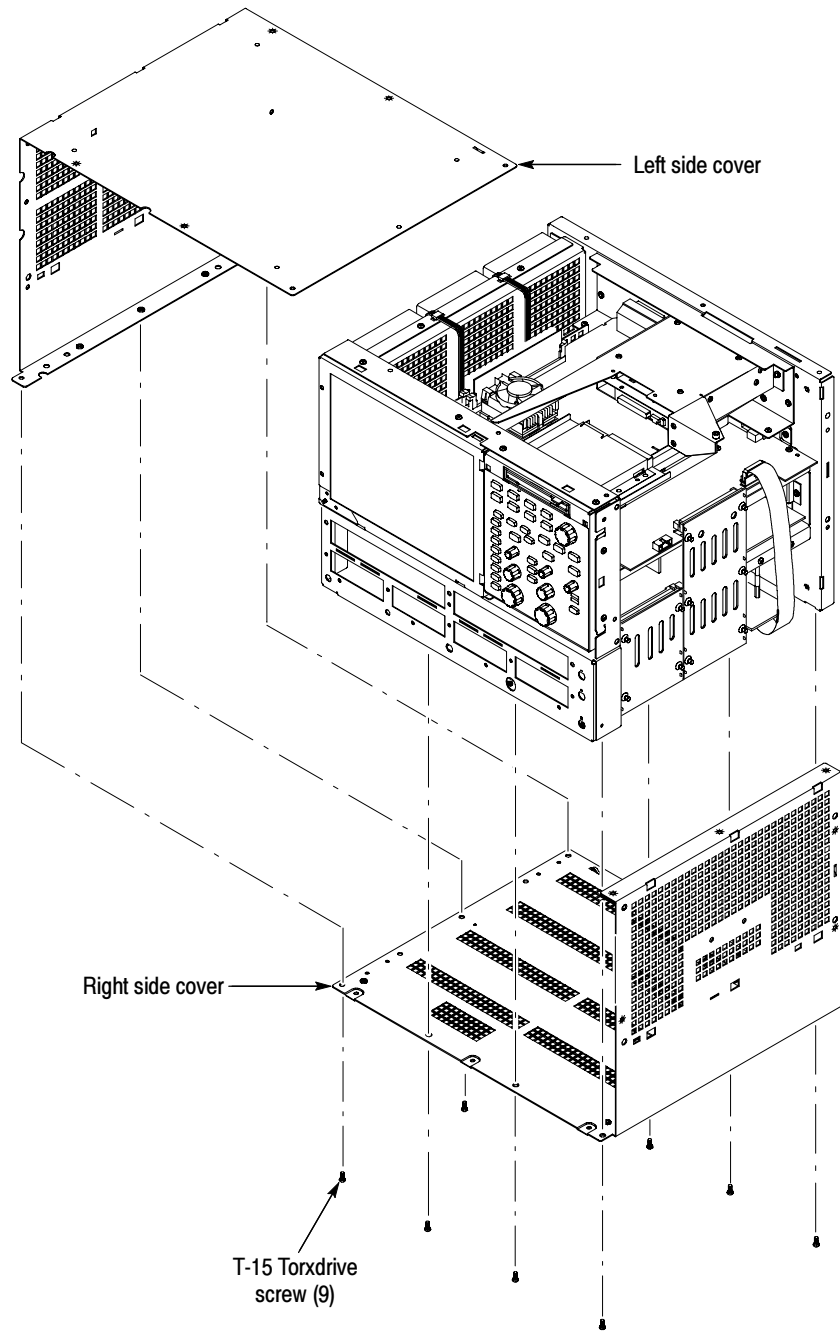

Figure 4-5: Cover removal

Line Fuses and AC power cord connector

1. *Assemble equipment and locate modules to be removed:* Locate the power switch, line fuses and AC power cord connector in Figure 4-6, page 4-17.
2. The instrument has a built-in soft power-off function that safely powers off the instrument when you press the On/Standby switch. You must power off the instrument using the Windows 98 shutdown process before depressing the front panel On/Standby switch.
3. Power off the rear panel power switch before servicing the line fuses or power cord.



CAUTION. *When powering off the instrument, use the Windows 98 shut down procedure. (Choose Shutdown from the Start menu.)*

Powering down the instrument without using the Windows 98 shut down procedure can corrupt the software on the hard disk.

4. *Orient the instrument:* Set the instrument so its bottom is down on the work surface and its rear is facing you. If you are servicing the line fuses, do the next step; if you are servicing the line cord, skip to step 6.
5. *Remove line fuses:* Find the fuse caps on the rear panel. Now, remove both fuse caps by turning them counterclockwise using a flat-bladed screwdriver, and remove the line fuses. Reverse procedure to reinstall.
6. *Remove line cord:* Find the line cord on the rear cover. Pull the line cord away to remove from the AC power connector. Reverse procedure to reinstall.
7. *Reinstallation:* Do in reverse steps 5 and 6 to reinstall the line cord and then the line fuse.

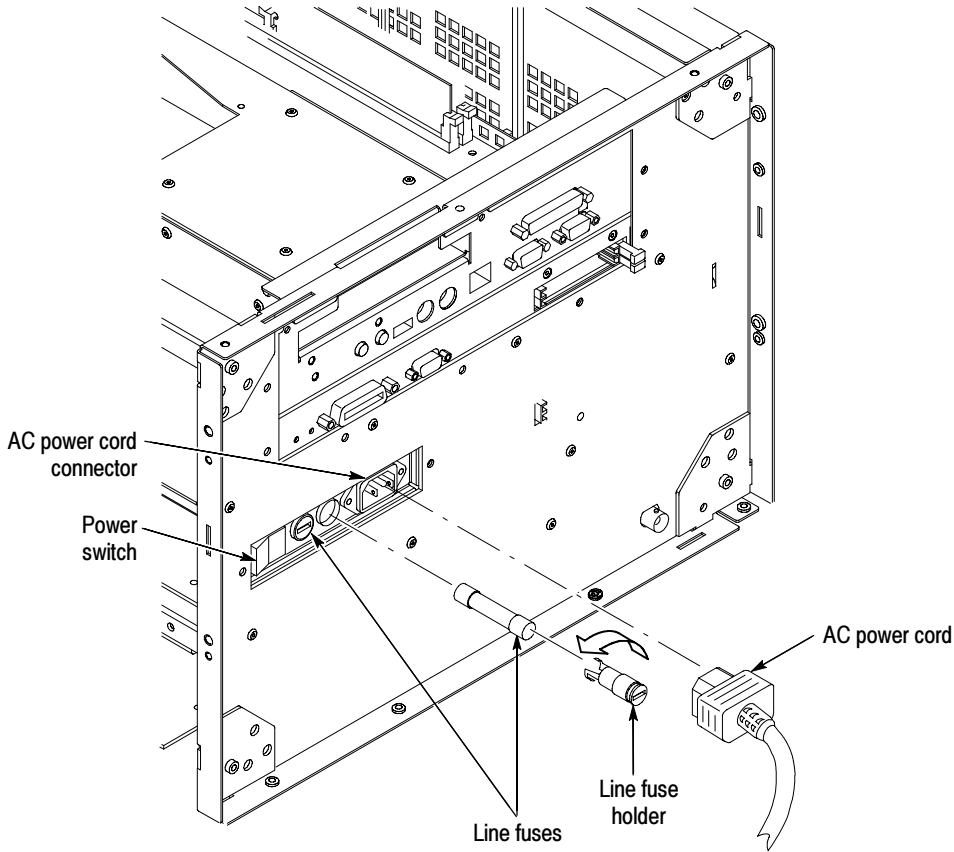

Figure 4-6: Line fuses and line cord removal

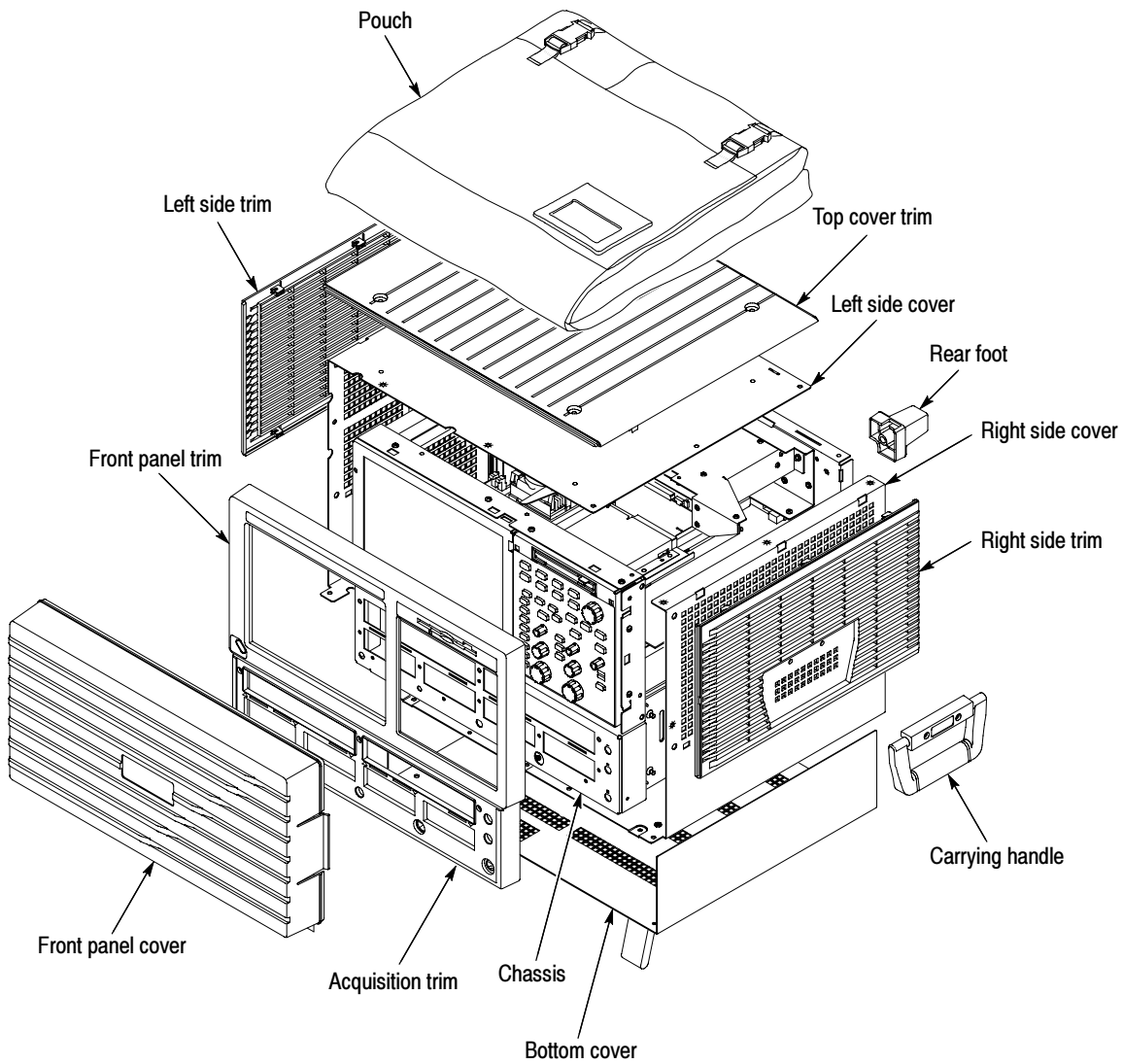

Figure 4-7: External modules

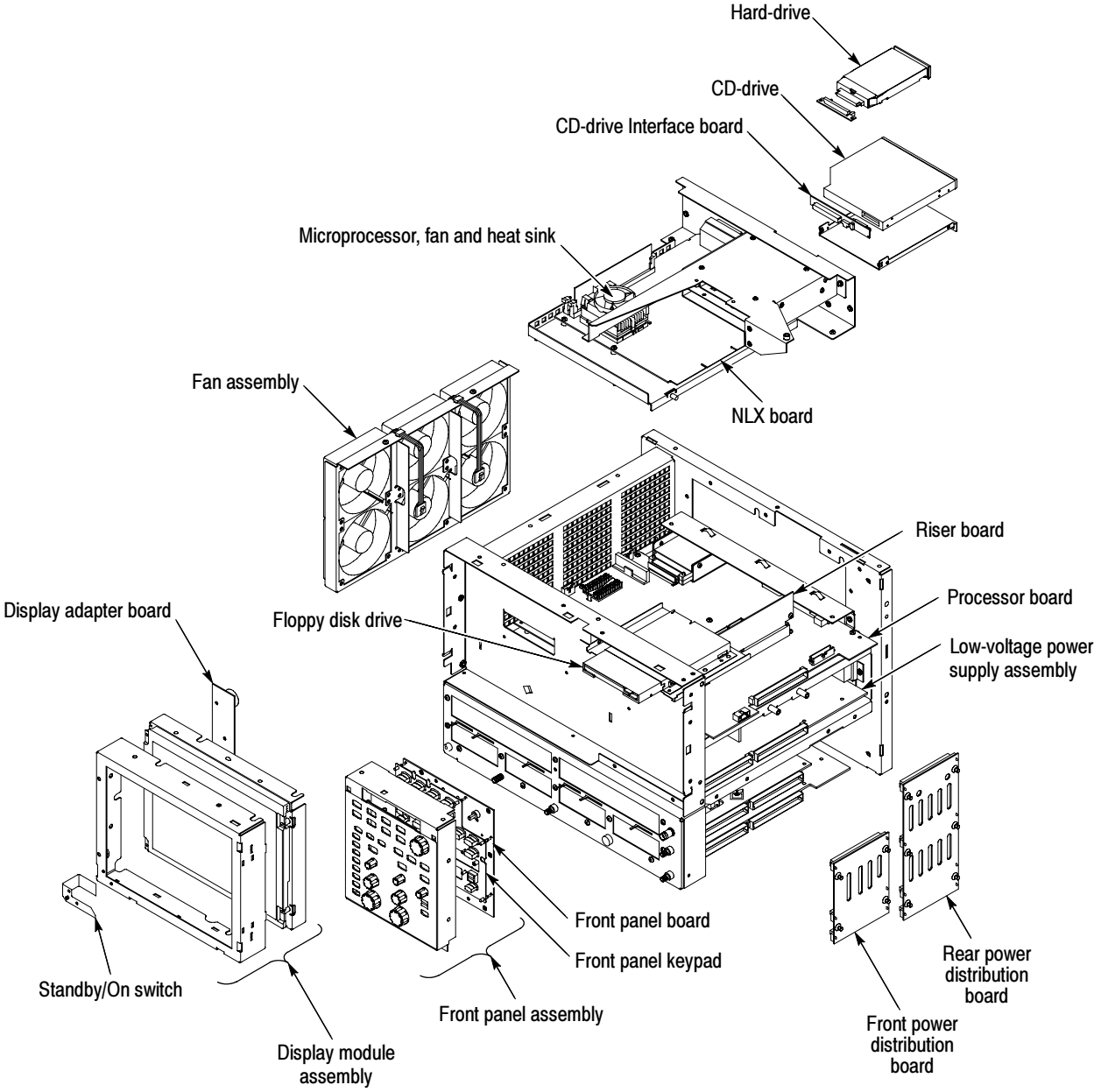

Figure 4-8: Internal modules

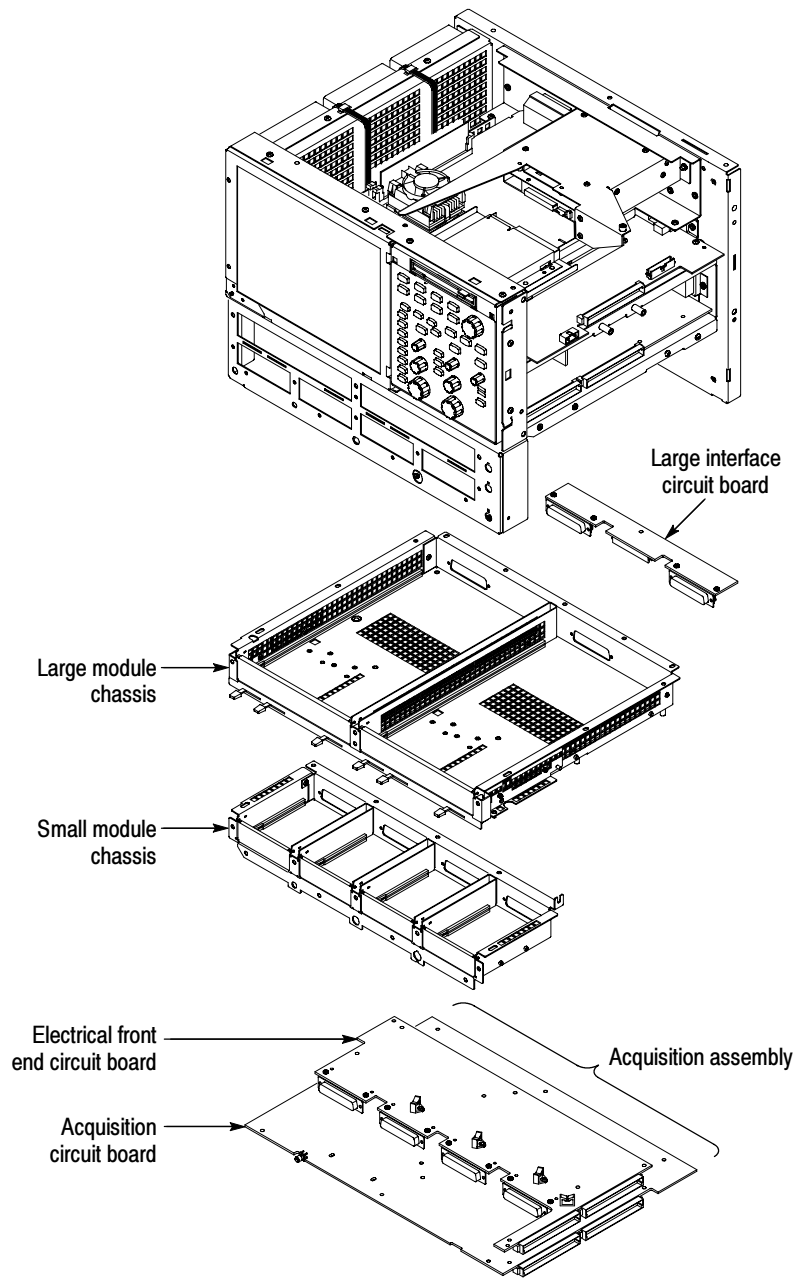

Figure 4-9: Acquisition modules

Procedures for Modules

You should have completed the Procedures for external modules before doing many of the procedures in this collection. The procedures found here are listed in disassembly order:

- Front Panel assembly
- Front Panel Board
- Front Panel Keypad
- Display assembly
- Display Adapter Board
- Standby/On Switch Flex Circuit
- Floppy Disk Drive
- Hard Disk Drive
- CD Drive
- Front and Rear Power Distribution Boards
- Low-Voltage Power Supply
- NLX Board
- Microprocessor
- PC Processor Board
- Fan assembly
- Acquisition assembly
- Large Module Interface Board
- Module Slot Doors
- Electrical Modules
- Optical Modules
- 80A00 and 82A00 Series Modules

Front Panel Assembly

1. *Locate module to be removed:* Locate the Front Panel assembly Figure 4-10, page 4-22. Additional modules to be removed:
 - Trim (Front panel)

2. *Remove the Front Panel assembly:* See Figure 4-10, page 4-22.
3. *Orient the instrument:* Set the instrument so its bottom is down on the work surface and its front panel is facing you.
 - a. Remove the six T-15 Torxdrive screws that secure the Front panel assembly to the front chassis.
 - b. Grasp the top of Front Panel assembly and pull forward to allow access to the ribbon cable connector on the front panel board.
 - c. Use the $\frac{1}{8}$ inch flat-bladed screwdriver to carefully lift J1 cable connector lock up to disconnect J1 flex cable from the display module assembly. See Figure 4-11, page 4-23. Note the connector's pin 1 index mark and the black stripe on the cable for later reassembly.
 - d. Pull the Front Panel assembly forward and remove from the instrument.
4. *Reinstallation:* Do in reverse steps a through d to reinstall the front panel assembly.

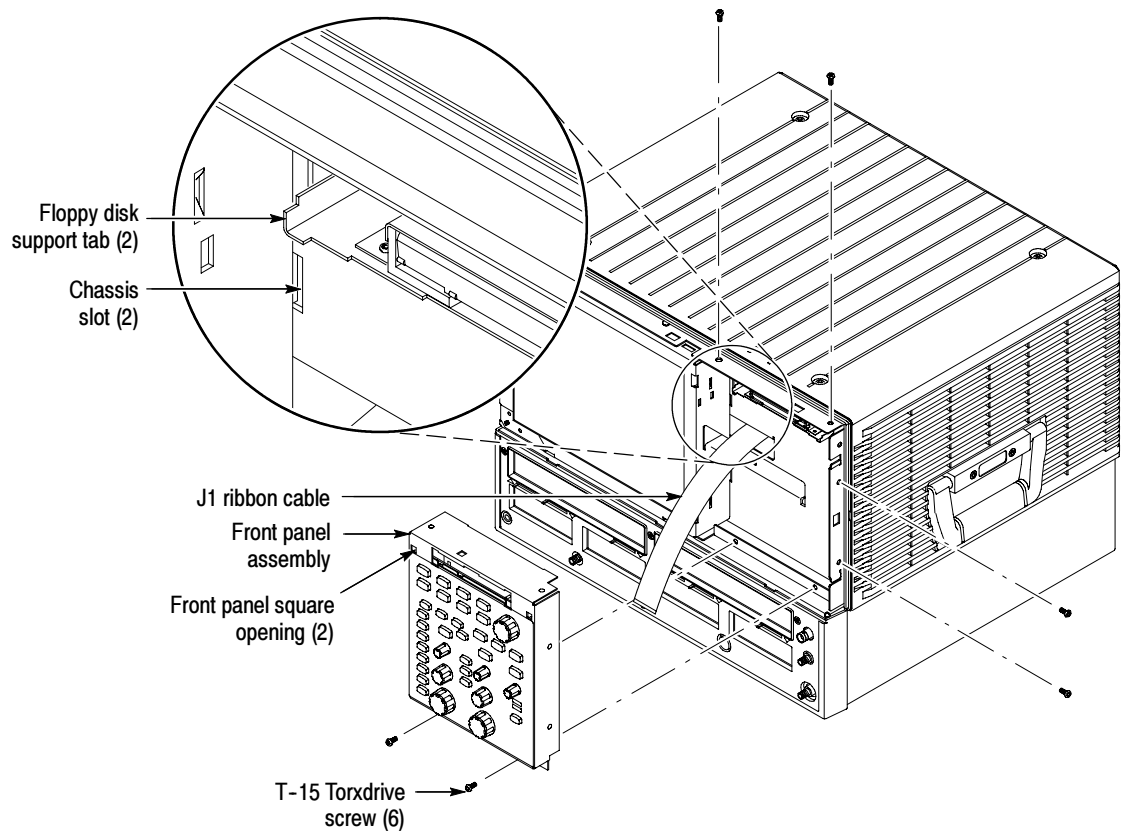

Figure 4-10: Front panel assembly removal

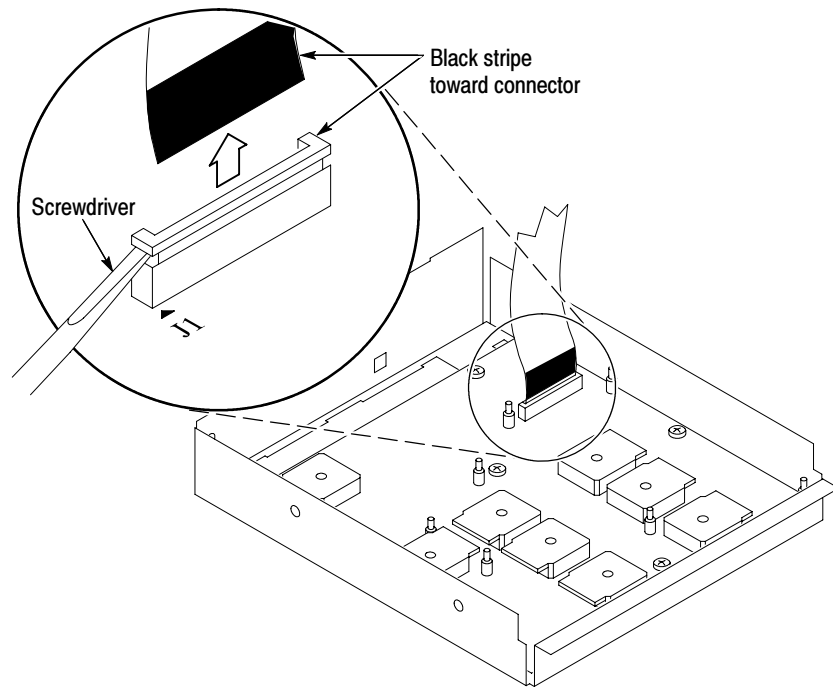

Figure 4-11: J1 flex cable connector removal

Front Panel Board

1. *Locate module to be removed:* Locate the Front Panel assembly Figure 4-10, page 4-22. Additional modules to be removed:
 - Front Panel Knobs
 - Trim (front panel)
 - Front Panel assembly
2. *Remove the Front Panel board:* See Figure 4-12, page 4-24.
 - a. Remove the eight T-15 Torxdrive screws that secure the Front panel board to the Front panel assembly.
 - b. Pry the board up off the alignment studs. Place a flat bladed screwdriver in the pry point access holes to pry the board up from the assembly.
 - c. Remove the board from the assembly.
3. *Reinstallation:* Do in reverse steps a through c to reinstall the front panel board.

Front Panel Keypad

1. *Locate module to be removed:* Locate the Front Panel assembly Figure 4-10, page 4-22. Additional modules to be removed:
 - Front Panel Knobs
 - Trim (front panel)
 - Front Panel assembly
 - Front Panel Board
2. *Remove the Front Panel keypad:* See Figure 4-12, page 4-24.
 - a. Pull on each of the keypad support guides to separate the keypad from the Front panel board. Use a pair of tweezers or equivalent tool to pull the keypad support guides.
 - b. Remove the keypad from the front panel board.

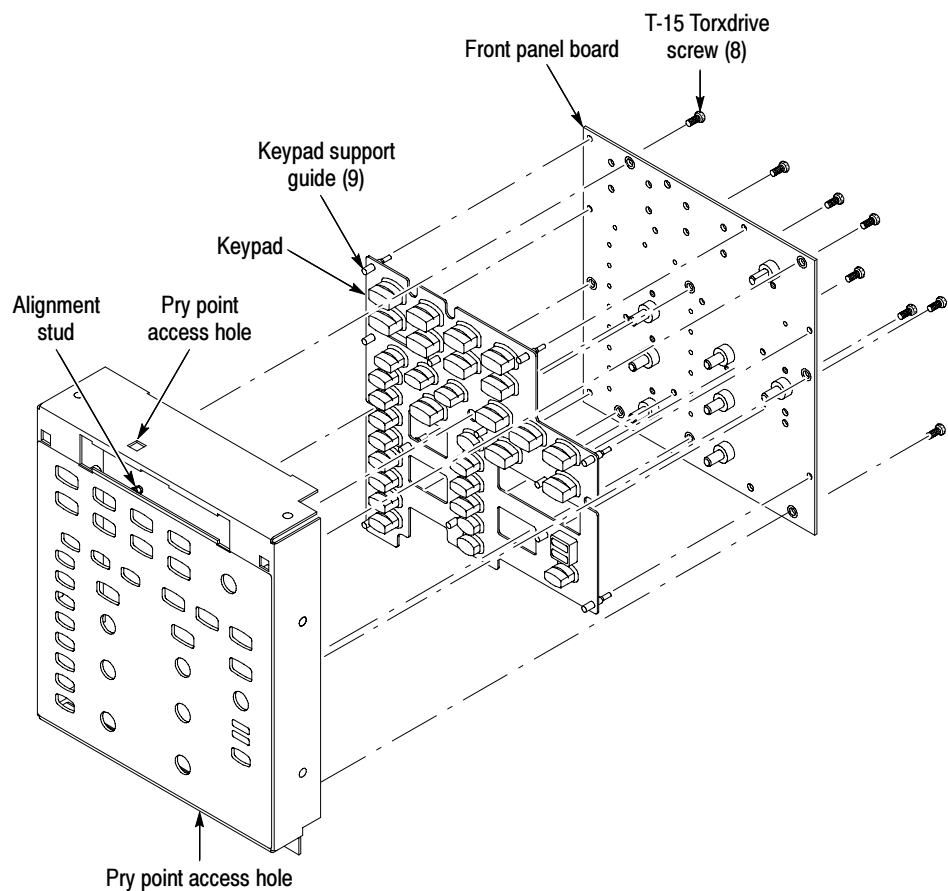

Figure 4-12: Front panel board and keyboard removal



CAUTION. When removing or installing the keypad, make sure you do not touch the switch contact with your fingers. The oils in your fingers will degrade or damage the switch contacts. To help prevent damage to the keypad use cotton gloves when removing or installing the keyboard pad.

3. *Reinstallation:* Do in reverse steps to reinstall the Keypad, front panel board, and the front panel assembly. Then see the following instructions:
 - a. Make sure the keypad is aligned properly on the Front Panel board.
 - b. Make sure the ribbon cable is routed correctly when installing the Front Panel into the chassis.
 - c. Insert the two floppy disk support tabs into the front panel square openings. Both left front panel tabs must go into the chassis slots. See Figure 4-10, page 4-22.

Display Assembly

1. *Locate module to be removed:* Locate the Display assembly, Figure 4-13, page 4-26. Additional modules to be removed:
 - Trim (front panel and top)
2. *Orient the instrument:* Set the instrument so its bottom is down on the work surface and its front panel is facing you.



CAUTION. To avoid damage to the front panel Standby/On switch assembly, do not set the Display module assembly on a work surface. Sliding the instrument over the edge of the work surface could break off the Standby/On switch assembly.

3. *Remove the Display assembly:* See Figure 4-13, page 4-26.
 - a. Remove the four T-15 Torxdrive screws that secure the Display assembly to the chassis.
 - b. Grasp the top edge of the Display assembly and pull forward far enough to allow access to the flex cable connector.
 - c. Disconnect J8 flex cable from the display assembly. Remove the display module assembly from the instrument. See Figure 4-13, page 4-26.

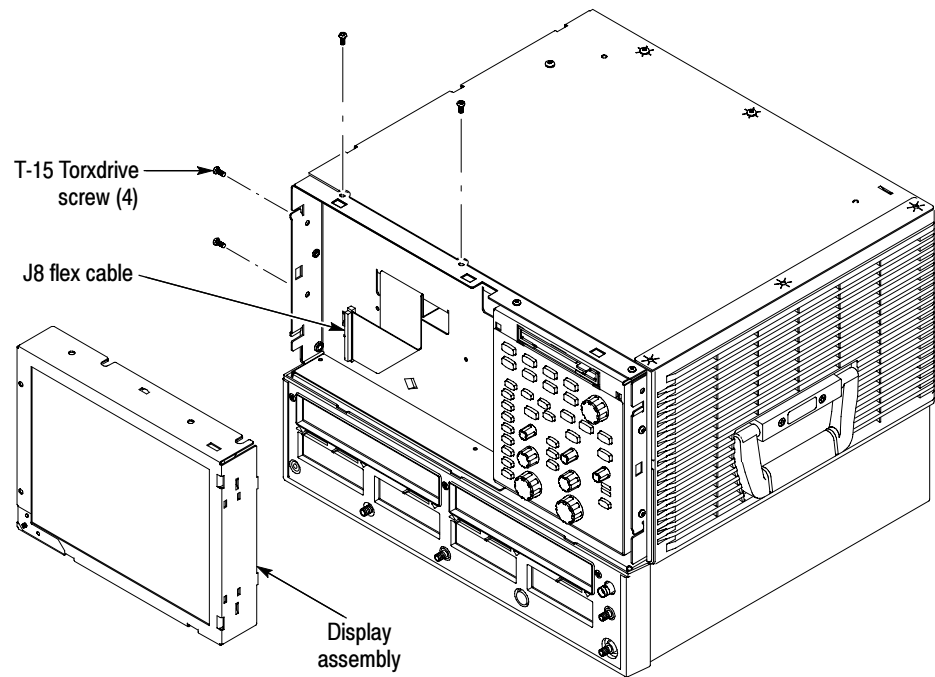

Figure 4-13: Display removal

4. *Remove the Touch panel from the Display assembly:* See Figures 4-14 and 4-15, pages 4-27 and 4-28.



CAUTION. *To prevent degradation of the display sharpness, this procedure must be performed in a dust free environment. The service technician should wear cotton gloves to prevent finger oils from contaminating all surfaces of the display glass.*

- a. Disconnect J1, J9 and J10 cables from the Display Adapter circuit board.
- b. Separate the assembly by carefully prying the Touch panel (outer) assembly from the Display (inner) assembly. Insert a flat-bladed screwdriver in the access notches to push out on the Touch panel assembly.

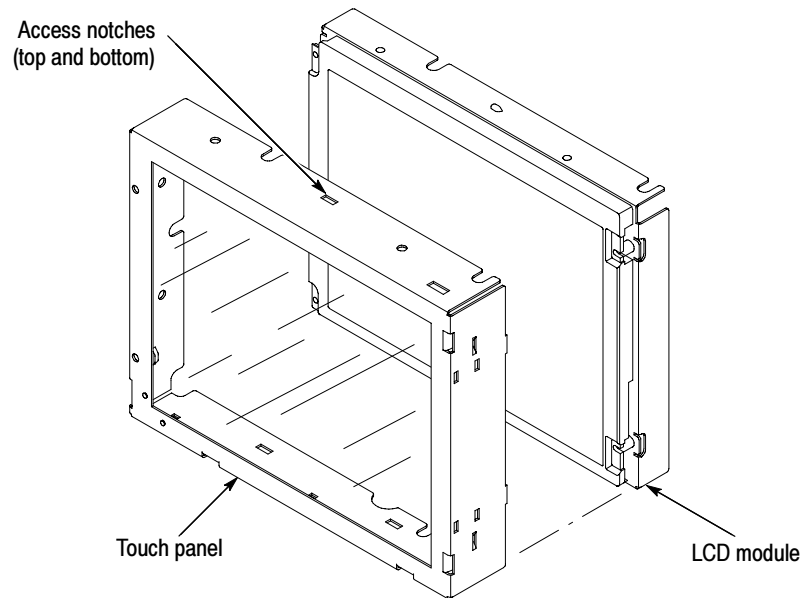

Figure 4-14: Touch panel and LCD assembly removal

5. *Reinstallation:* Do in reverse steps 1 through 5 to reinstall the Display assembly.

Display Adapter Board

1. *Locate module to be removed:* Locate the display adapter board in the locator diagram *Internal Modules*, Figure 4-7, page 4-18. Additional modules to be removed:
 - Trim (front panel and top)
 - Display assembly
2. *Remove the Display Adapter Board:* See Figures 4-15 and 4-16, page 4-28.
 - a. Disconnect J11, J1, J7, J8, and J9 cables from the Display Adapter board.
 - b. Slide the clip off the connector (at J10).
 - c. Disconnect J10 cable from the Display Adapter board.
 - d. Remove the two T-15 Torxdrive screws that secure the Display Adapter circuit board to the Display assembly. Remove the Display Adapter from the assembly.
3. *Reinstallation:* Do in reverse steps 2a through 2d to reinstall the board.

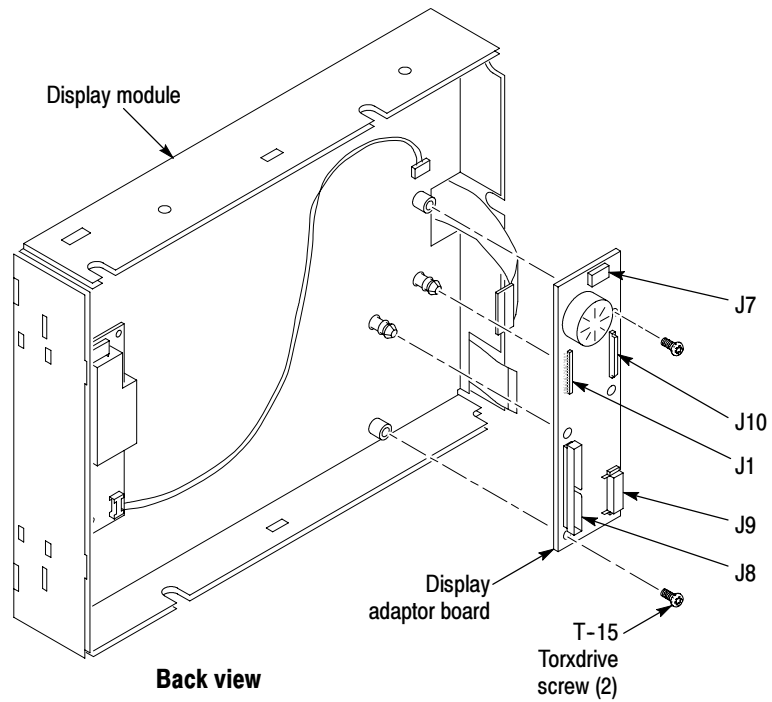

Figure 4-15: Display adaptor board removal

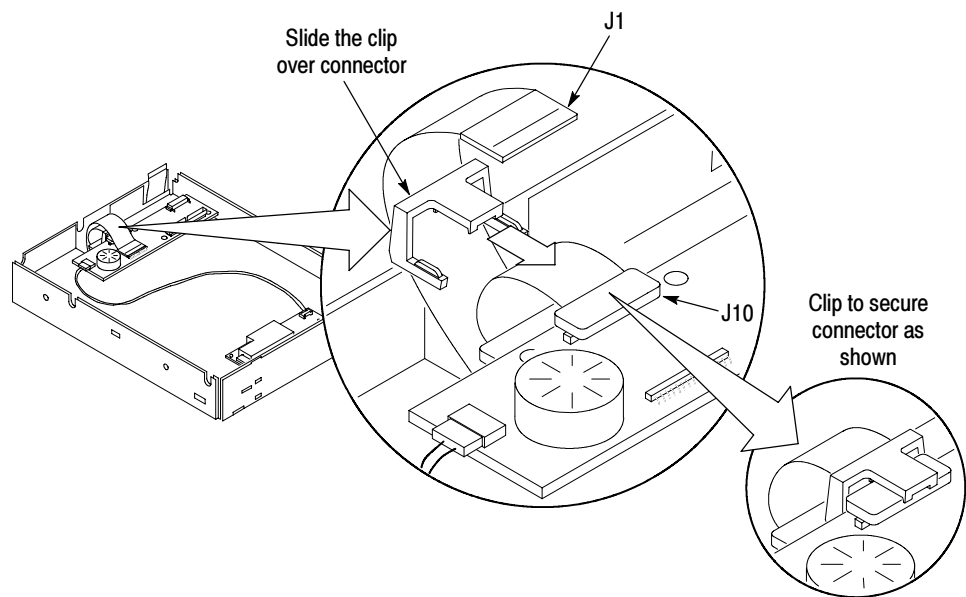

Figure 4-16: Connector clip assembly

**Standby/On Switch Flex
Circuit Removal**

1. *Locate module to be removed:* Locate the Standby/On Switch flex circuit in the locator diagram *Internal Modules*, Figure 4-8, page 4-19. Additional modules to be removed:
 - Trim (front panel and top)
 - Display assembly
2. *Orient the oscilloscope:* Set the oscilloscope so its bottom is down on the work surface and its front is facing you.
3. *Remove the Standby/On Switch flex circuit:* See Figure 4-17, page 4-30.
 - a. Peel the Standby/On switch flex circuit away from the front of the display assembly.
 - b. Disconnect the flex circuit from J9 on the Display Adapter circuit board.
 - c. Grasp the flex circuit and pull it out of the Display assembly.
4. *Reinstallation:* Do following procedure to reinstall the Standby/On Switch.
 - a. Remove the protective backing on the Standby/On switch flex circuit.
 - b. Slide the connector end of the Standby/On switch flex circuit through the slot in the Display assembly. Make sure the flex circuit connector aligns with J9 on the Display Adapter circuit board.
 - c. Align the holes in the flex circuit to the two index posts on the front side of the Display assembly.
 - d. Firmly press the flex circuit to the Display assembly chassis surface.

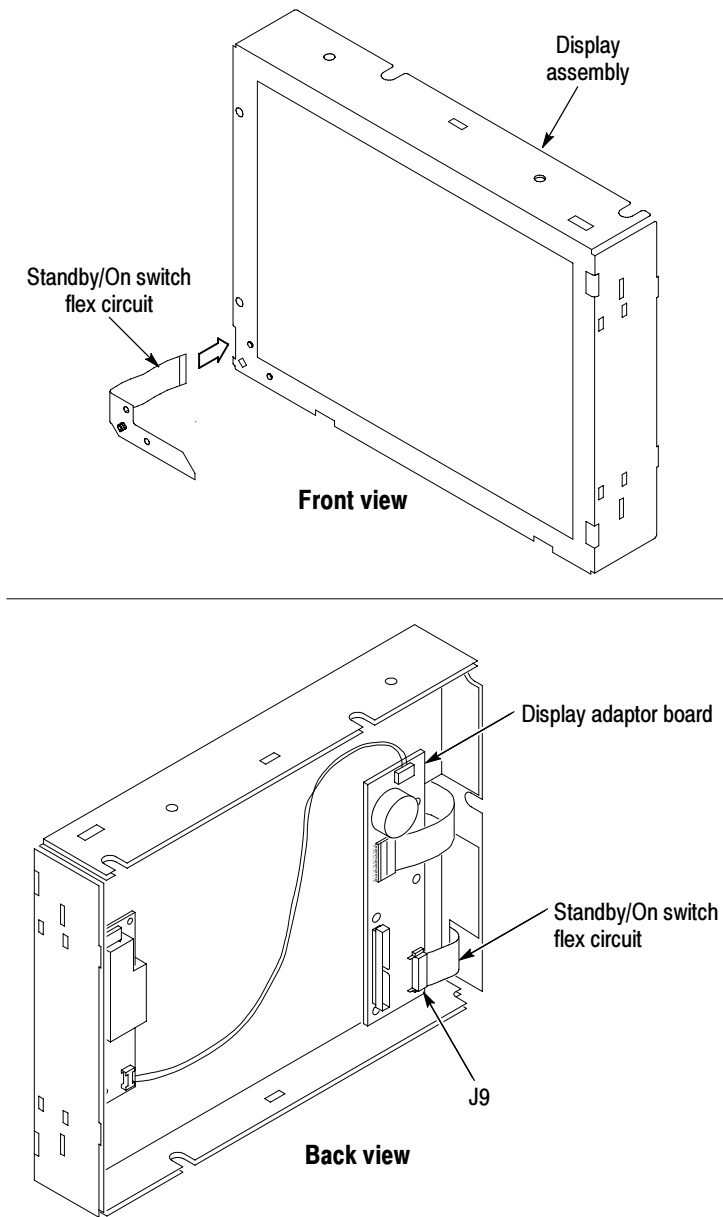
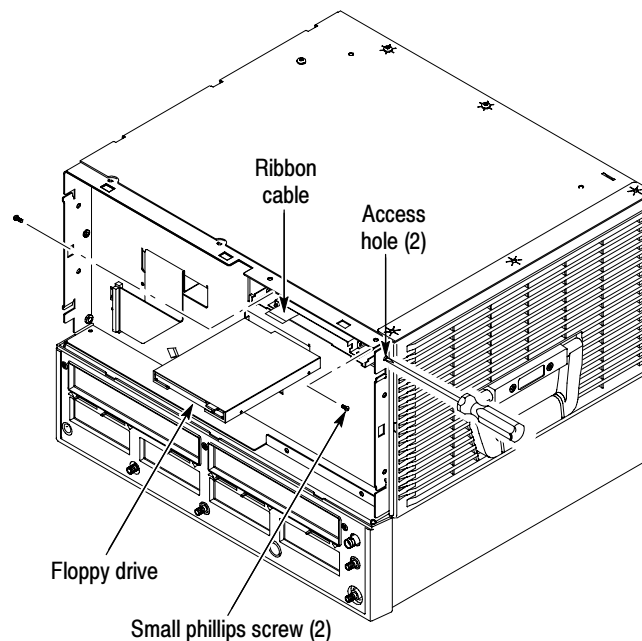

Figure 4-17: Standby/On switch flex circuit removal

Floppy Disk Drive

1. *Locate modules to be removed:* Locate the Floppy Disk Drive in the locator diagram *Internal Modules*, Figure 4-8, page 4-19. Additional modules to be removed:
 - Trim (front panel and top)
 - Front Panel assembly
 - Display assembly
2. *Remove the floppy disk drive:* Use Figure 4-18, page 4-31 as a guide. A #0 phillips screwdriver is required for this procedure.
3. *Orient the instrument:* Set the instrument so its bottom is down on the work surface and its front panel is facing you.
 - a. Remove the two small phillips screws that secure floppy disk drive assembly to the bracket. Use the access hole located on the outer chassis to remove one of the small phillips screws.
 - b. Slide the floppy drive out toward the front of the instrument far enough to allow you to disconnect the ribbon cable connector.
 - c. Remove the floppy drive from the instrument.
4. *Reinstallation:* Do in reverse steps a through c to reinstall the floppy disk drive.

**Figure 4-18: Floppy disk drive removal**

Hard Disk Drive

1. *Locate module to be removed:* Locate the Hard Disk Drive in the locator diagram *Internal Modules*, Figure 4-8, page 4-19.



CAUTION. *Do not remove the replaceable hard disk drive when the mainframe is powered on.*

The replaceable hard disk drive may be permanently damaged if it is removed while the mainframe is powered on.

Always power down the mainframe before removing the replaceable hard disk drive.

2. *Orient the instrument:* Set the instrument so its bottom is down on the work surface and its rear panel is facing you.
3. *Remove the hard disk drive:* See Figure 4-19, page 4-33.
 - a. Verify that the chassis is powered down.
 - b. Push the hard disk drive cover in and the hard drive will disconnect from the latch.
 - c. Grasp the hard disk drive assembly and slide it out of the instrument.
4. *Reinstallation:* Do in reverse steps a and b to reinstall the hard disk drive assembly. The hard disk drive will push in to lock and push in again to unlock.

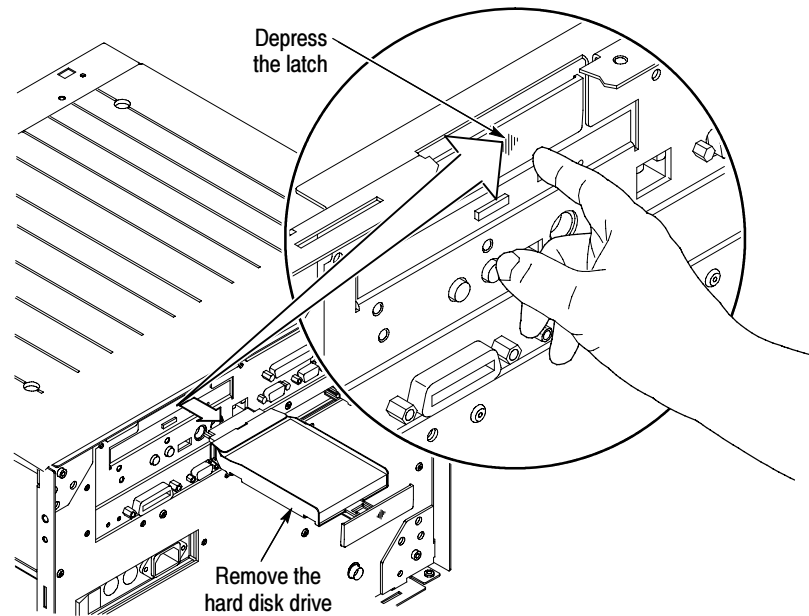

Figure 4-19: Hard drive disk removal

5. *Remove the hard disk drive from the cartridge:* See Figure 4-20, page 4-33.
 - a. Remove the four #0 phillips screws that fasten the hard disk drive to the cartridge.
 - b. Carefully remove the hard disk drive from the cartridge, and remove the cable assembly from the connector on the hard disk drive.

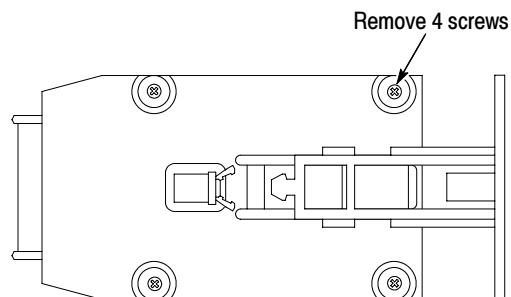

Figure 4-20: Removing the hard disk drive from the cartridge

- CD Drive**
1. *Locate module to be removed:* Locate the CD Drive in the locator diagram *Internal Modules*, Figure 4-8, page 4-19. Additional modules to be removed:
 - Trim (all)
 - Bottom cover
 - Left and Right covers
 2. *Remove the CD Drive assembly:* See Figure 4-21, page 4-35.
 3. *Orient the instrument:* Set the instrument so its bottom is down on the work surface and its rear panel is facing you.
 - a. Remove the two T-15 Torxdrive screws that secure CD Drive assembly to the rear chassis.
 - b. Disconnect the CD Drive ribbon cable J230, from Riser board.
 - c. Slide the CD Drive assembly (with the cable attached) toward the rear of the chassis and remove it from the instrument.
 4. *Remove the CD Drive bracket and Rom interface board:* See Figure 4-21, page 4-35.
 - a. Remove the four #0 phillips screws that secure the bracket to the CD Drive. Remove the CD Drive from the bracket.
 - b. Remove the Interface board from the CD Drive by pulling the Interface board straight back until they separate.
 5. *Reinstallation:* Do in reverse steps 3 and 4 to reinstall the CD Drive assembly.

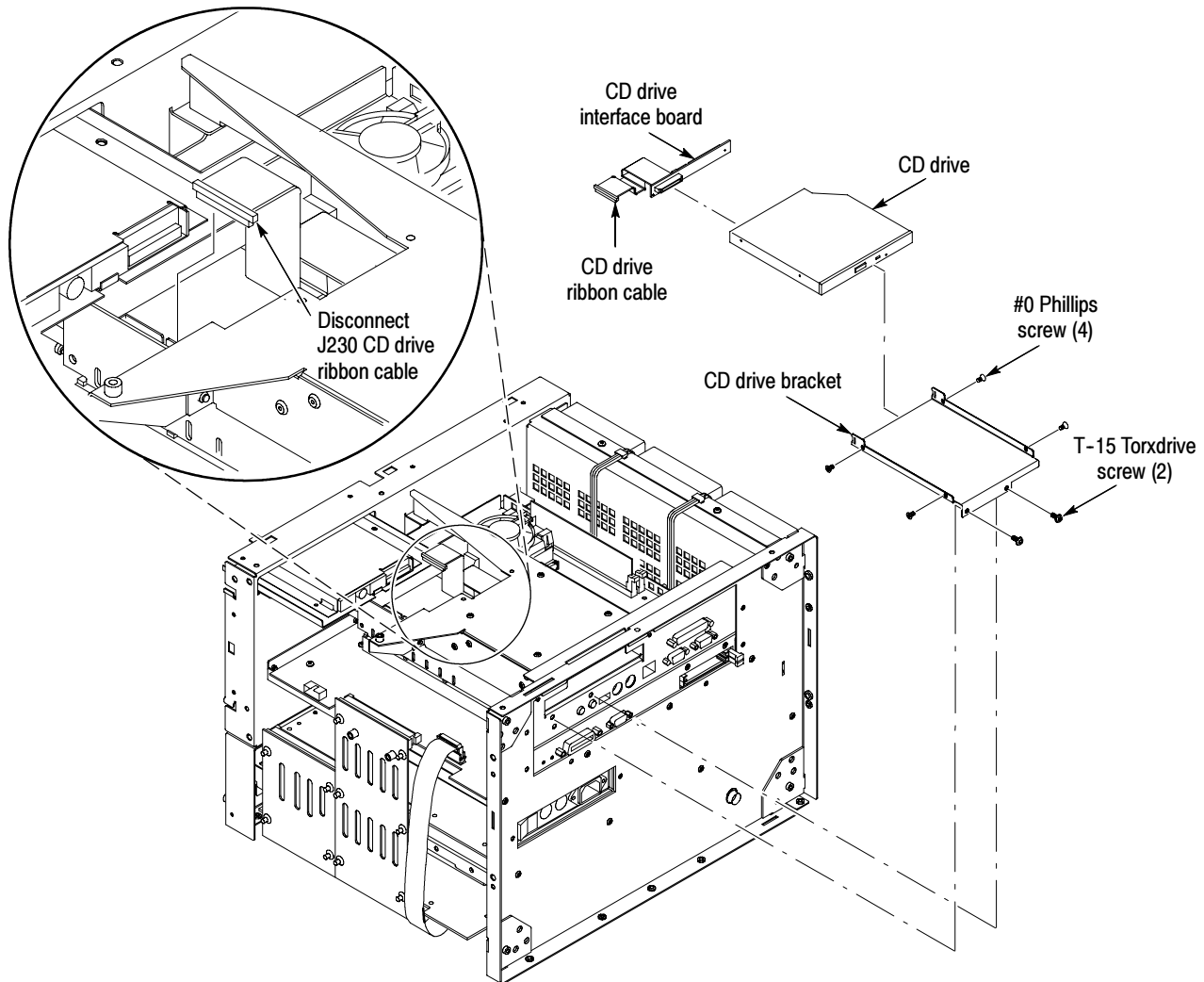

Figure 4-21: CD drive and bracket removal

Fan Assembly Removal

1. *Locate module to be removed:* Locate the Fan assembly in the locator diagram *Internal Modules*, Figure 4-8, page 4-19. Additional modules to be removed:
 - Trim (all)
 - Bottom cover
 - Left and Right covers
2. *Orient the instrument:* Set the instrument so its bottom is down on the work surface and its left side is facing you.

3. *Remove the fan assembly:* See Figure 4-22, page 4-36.



CAUTION. Take care when handling the fan assembly, the fan blades are brittle and can be easily damaged.

- a. *Disconnect the fan from processor/display board:* Disconnect the fan's two power cables J130 and J170 located on the processor board.
 - b. Remove the two T-15 Torxdrive screws securing the fan assembly to the top main chassis.
 - c. Lift the fan assembly up and out from the chassis.
4. *Reinstallation:* Do in reverse steps a through c to reinstall the fan assembly.

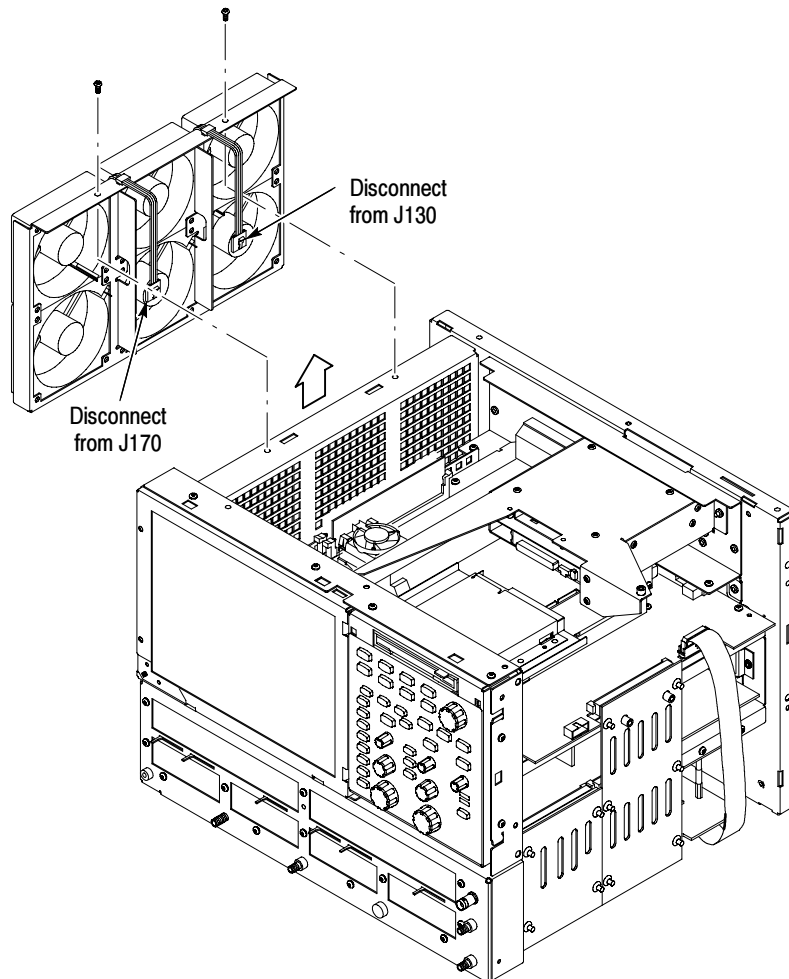

Figure 4-22: Fan assembly removal

Front and Rear Power Distribution Boards

1. *Assemble equipment and locate modules to be removed:* Find the modules to be removed in the locator diagram *Internal Modules*, Figure 4-8, page 4-19. Additional modules to be removed:
 - Trim (all)
 - Bottom cover
 - Left and Right covers
2. *Orient the instrument:* Set the instrument so its left side is down on the work surface and its right side is facing you.
3. *Remove the Front power distribution board:* See Figure 4-23, page 4-37.
 - a. Grasp the Front power distribution board and pull it out from the instrument to disconnect it from the following connectors; J2 Power supply board, J102 Electrical front-end board, and J202 Acquisition board.
 - b. *Remove the Rear power distribution board:* Grasp the Rear Power Distribution board and pull it out from the instrument to disconnect it from the following connectors; J201 Processor board, J1 Power supply board, J301 Electrical front-end board, and J102 Acquisition board.
4. *Reinstallation:* Do in reverse steps a and b to reinstall the front and rear power distribution circuit boards.

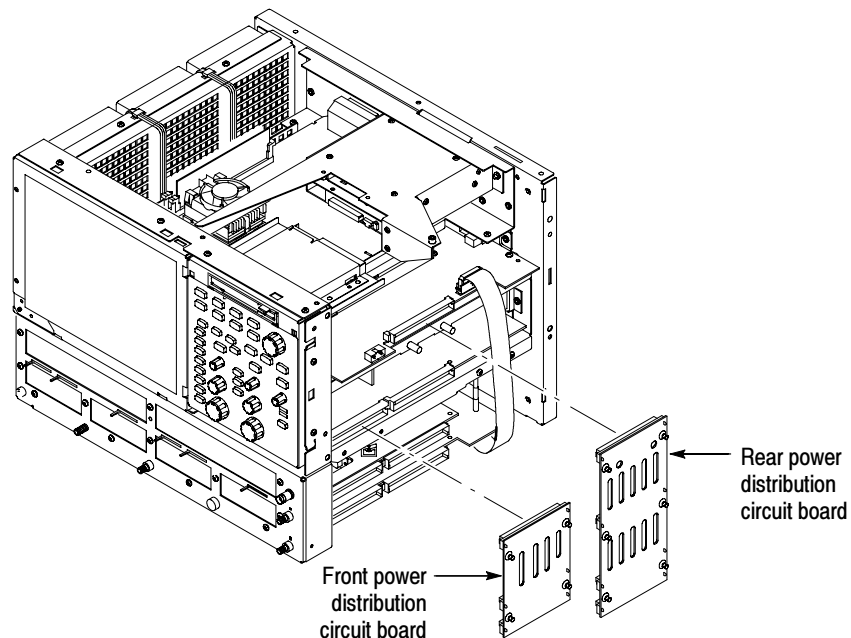

Figure 4-23: Front and rear power distribution board removal

Low-Voltage Power Supply

1. *Assemble equipment and locate modules to be removed:* Locate the modules to be removed in the locator diagram *Internal Modules*, Figure 4-8, page 4-19. Additional modules to be removed:

NOTE. *In addition to this topic, see Checking the Power Supply Voltages on page 4-74 in the Troubleshooting section.*

- Trim (all)
 - Bottom cover
 - Left and Right covers
 - Front and Power rear distribution boards
2. *Orient the instrument:* Set the instrument so its bottom is down on the work surface and its right-side is facing you.
 3. *Remove the low-voltage power supply:* See Figure 4-24, page 4-39.
 - a. Disconnect J930 ribbon cable connector from the PC processor board.
 - b. Remove the two T-15 Torxdrive screws securing the low-voltage power supply to the right-side chassis support.
 - c. Remove the three T-15 Torxdrive screws securing the low-voltage power supply to rear chassis.
 - d. Grasp the low-voltage power supply and carefully slide the assembly out of the mainframe.
 4. *Reinstallation:* Do in reverse steps a through c to reinstall the low-voltage power supply.

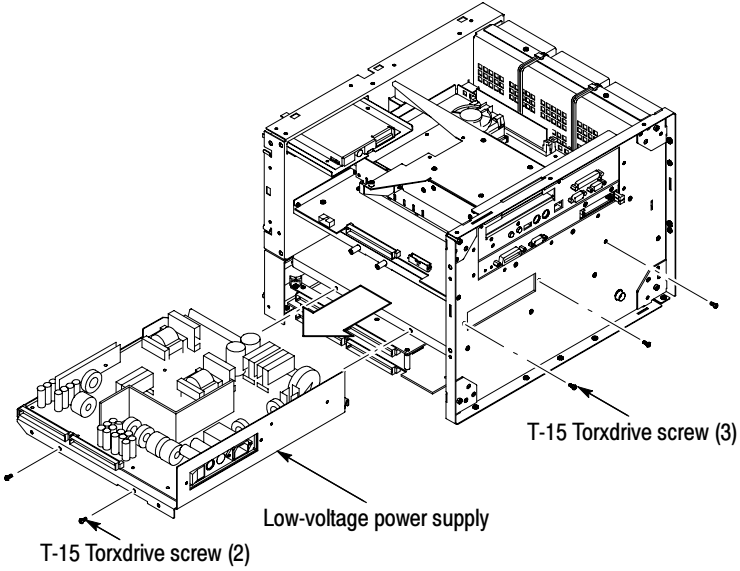

Figure 4-24: Low-voltage power supply removal

- NLX Board**
1. *Locate module to be removed:* Locate the NLX Board in the locator diagram *Internal Modules*, Figure 4-8, page 4-19. Additional modules to be removed:
 - Trim (all)
 - Bottom cover
 - Left and Right covers
 2. *Remove the NLX Board assembly:* See Figure 4-25, page 4-41.
 3. *Orient the instrument:* Set the instrument so its bottom is down on the work surface and its top panel is facing you.
 - a. Remove the two T-15 Torxdrive screws that secure the floppy disk drive assembly into the front chassis.
 - b. Slide the floppy drive assembly, with cable attached, out toward the rear of the instrument. Place floppy drive assembly on top of the hard/CD drive bracket.
 - c. Remove the five T-15 Torxdrive screws that secure NLX board assembly to the chassis.
 - d. Remove the five T-15 Torxdrive screws that secure NLX board assembly to the rear chassis.
 - e. Grasp the front edge of the NLX board assembly and pull up on the assembly to disconnect the Riser Adapter from the PC Processor board's edge connector.
 - f. Remove the NLX board assembly from the instrument.

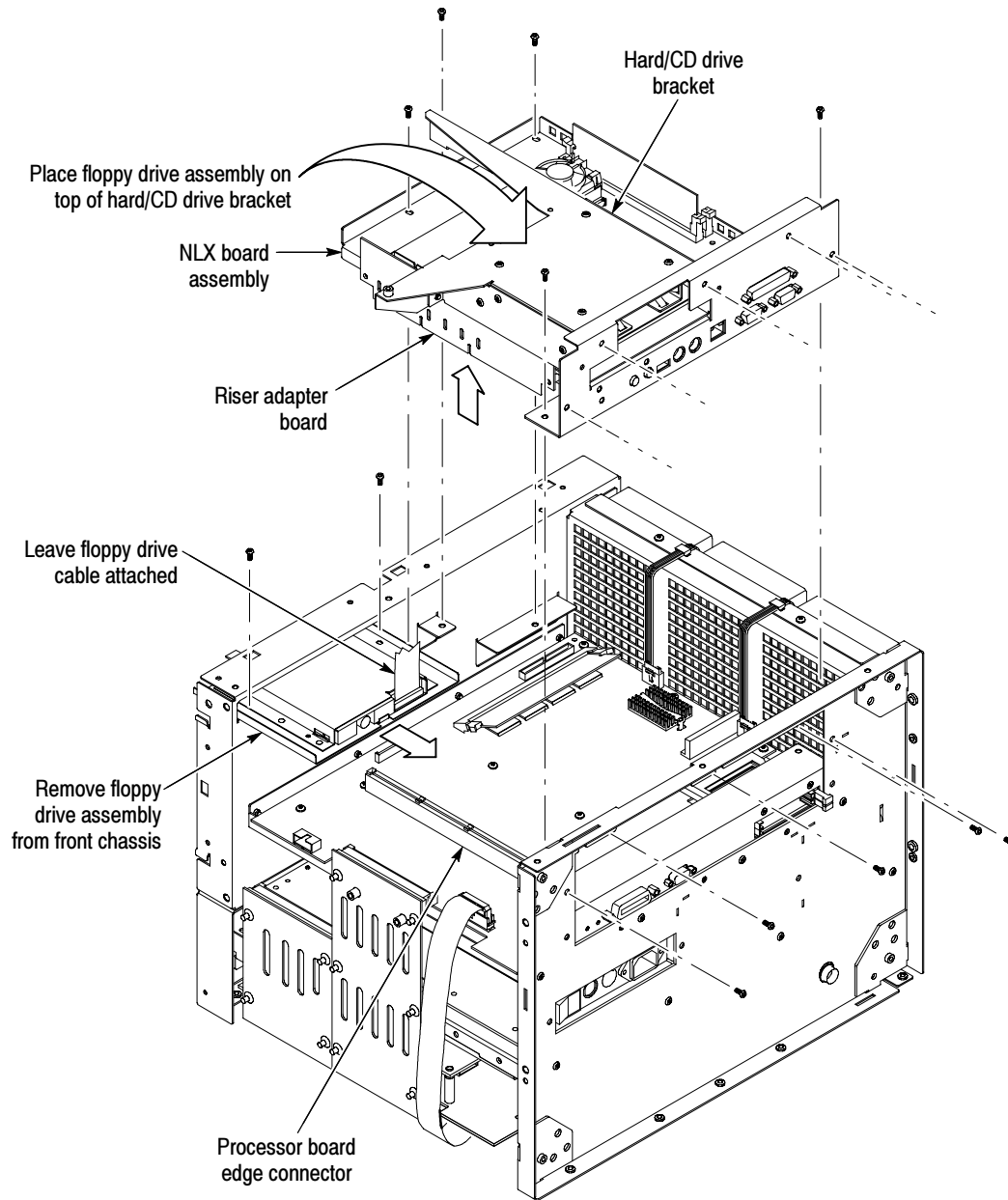

Figure 4-25: NLX assembly removal

4. *Remove the Riser Adapter and NLX boards:* See Figure 4-26, page 4-42.
 - a. Remove the two T-15 Torxdrive screws that secure Riser Adapter board to the NLX support bracket.
 - b. Disconnect the ribbon cable connectors from the floppy drive, hard drive and CD drive.

- c. Remove the floppy drive assembly from the NLX board assembly.
 - d. Grasp the Riser board and pull it straight out to disconnect J510 edge card connector from the NLX board. Remove the Riser Adapter board from the NLX board assembly.
 - e. Remove the four T-15 Torxdrive screws that secure NLX board to the NLX support bracket.
 - f. Remove the six 3/16 nut posts that secure the three connectors to the rear of the support bracket. Then remove the NLX board from the support bracket.
 - g. Remove the NLX board from the support bracket.
5. *Reinstallation:* Do in reverse steps 3 and 4 to reinstall the NLX board.

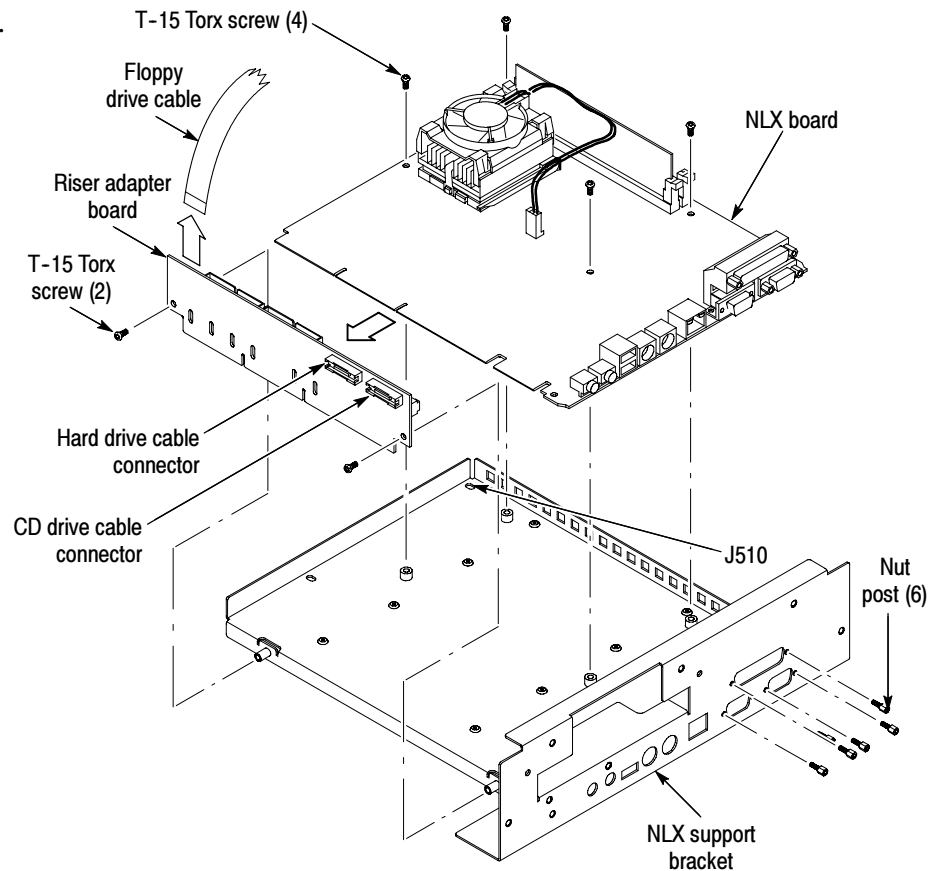

Figure 4-26: Riser adapter and NLX board removal

Microprocessor

1. *Locate module to be removed:* Locate the Front Panel board in the locator diagram *Internal Modules*, Figure 4-8, page 4-19. Additional modules to be removed:
 - Trim
 - Bottom cover
 - Left and Right covers



CAUTION. *The microprocessor is susceptible to static-discharge damage. Service this component only in a static-free environment. Observe standard handling precautions for static-sensitive devices while servicing the chassis. Always wear a grounded wrist and foot straps while servicing the microprocessor, NLX or processor boards.*

2. *Remove the microprocessor:* See Figure 4-27, page 4-44.
 - a. Disconnect the fan power cable J401 from the NLX board.
 - b. Push down and pull out on the holding bracket located nearest to the outer edge of the circuit board.
 - c. Pull out and unlatch the remaining bracket. Lift the fan/heatsink assembly out from the microprocessor.
 - d. Lift the microprocessor socket locking lever upward. Remove the microprocessor.
3. *Reinstallation:* To reinstall the microprocessor to the NLX board as follows:
 - a. Install the microprocessor in the socket.
 - b. Lower the socket locking lever.
 - c. Make sure the fan/heatsink assembly is positioned with the fan cable toward the outer edge of the circuit board.
 - d. Place the fan/heatsink assembly on the microprocessor to allow you to latch the bracket to the tab that is nearest to the center of the circuit board.
 - e. Set the remaining edge of the fan/heatsink down on the microprocessor and fasten the remaining bracket to the assembly.
 - f. Connect the fan power cable J401 from the NLX board.

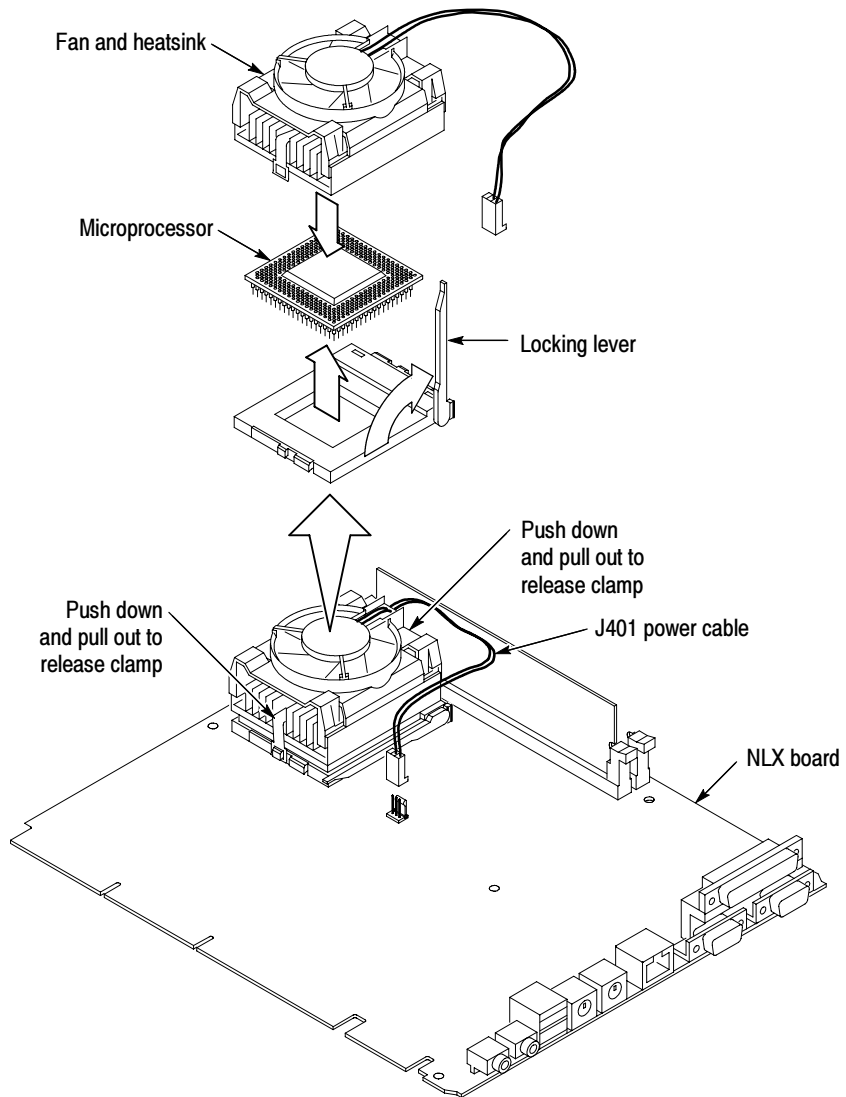

Figure 4-27: Microprocessor removal

PC Processor Board

1. *Locate module to be removed:* Locate the PC Processor Board assembly in the locator diagram *Internal Modules*, Figure 4-8, page 4-19. Remove the following in this order:
 - Trim (all)
 - Bottom cover
 - Left and Right covers
 - Hard Disk and CD Drive
 - Floppy Disk Drive
 - NLX Board
 - Front and Rear Power Distribution Boards
2. *Orient the instrument:* Set the instrument so its bottom is down on the work surface and its top panel is facing you.
3. *Remove the PC Processor board assembly:* See Figure 4-28, page 4-46.
 - a. Disconnect J190 and J691 ribbon cables from the PC processor board.
 - b. Remove the nine T-15 Torxdrive screws securing the PC processor board to the chassis support.
 - c. Remove the five T-15 Torxdrive screws securing the PC processor board assembly to the rear chassis.
4. *Remove the PC Processor Board:* See Figure 4-28, page 4-46.
 - a. Remove the two $\frac{3}{16}$ nut posts that secure the RS-232 connector to the rear of the support bracket.
 - b. Remove the two $\frac{5}{16}$ nut posts that secure the sub-D connector to the rear of the support bracket.
 - c. Remove the two phillips screws that secure the PCMCIA (Personal card, memory card interface adapter) to the pc processor board. Remove the PCMCIA from the PC processor board.
 - d. Disconnect J930 ribbon cable connector from the PC processor board.
 - e. Then remove the PC processor board from the instrument.
5. *Reinstallation:* Do in reverse steps 3 and 4 to reinstall the PC processor assembly.

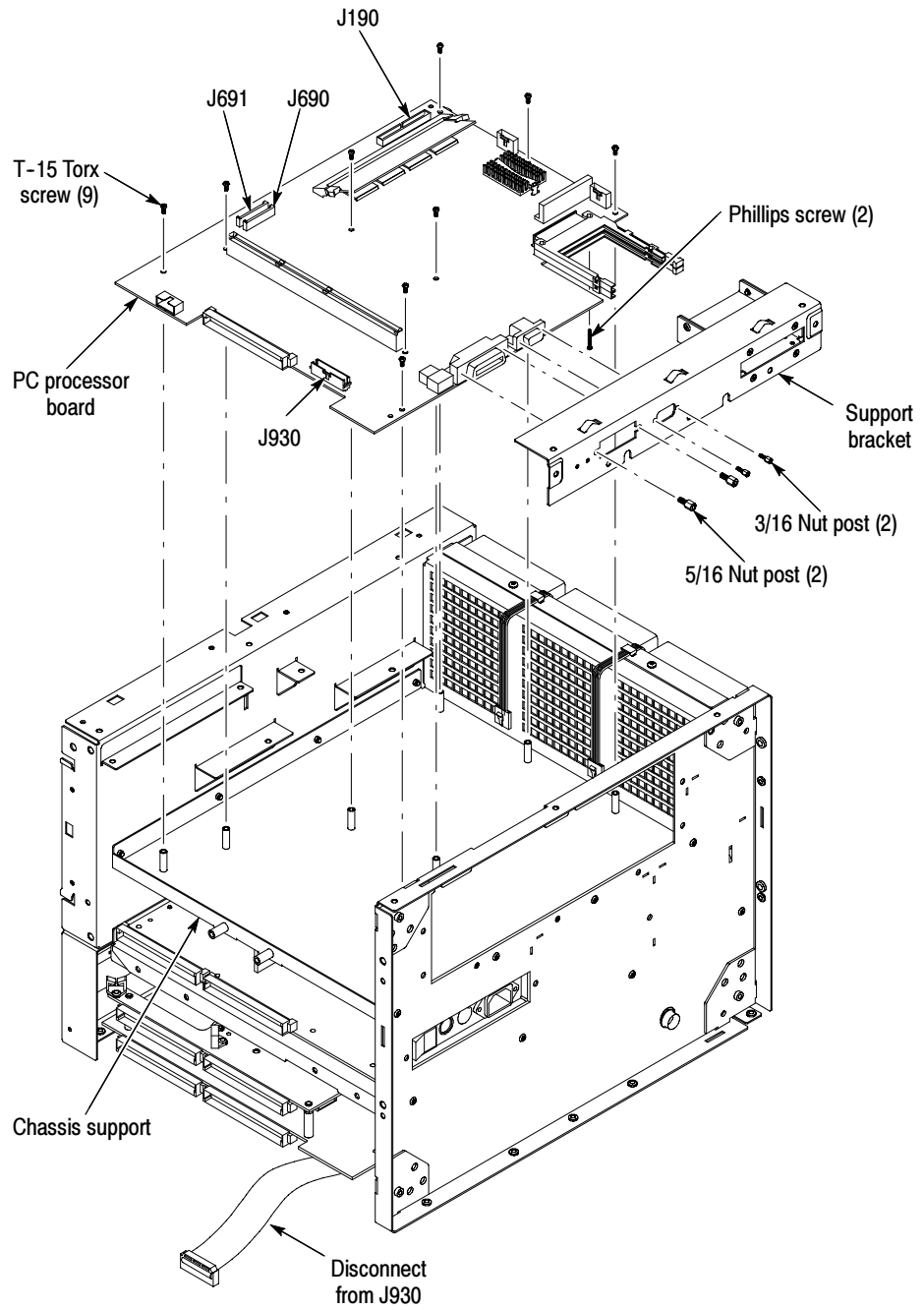

Figure 4-28: Processor board removal

Acquisition Assembly

1. *Locate module to be removed:* Locate the Acquisition assembly in the locator diagram, Figure 4-9, page 4-20. Remove the Acquisition assembly following in this order:
 - Trim
 - Bottom cover
 - Left and Right covers
 - Front and Rear Power Distribution Boards
2. *Orient the instrument:* Set the instrument so its top is down on the work surface and its bottom is facing you.
3. *Remove the Acquisition assembly:* The Acquisition assembly includes, the Acquisition board and Electrical Front End board. See Figure 4-31, page 4-50 (8000 instrument), Figure 4-32, page 4-51 (8000B instrument), or Figure 4-33, page 4-52 (8200 instrument).
 - a. Remove the $\frac{5}{16}$ inch nut that secures the TRIGGER PRESCALE SMA cable to the front panel.
 - b. Remove the ten T-15 Torxdrive screws securing the Acquisition assembly to the chassis.

NOTE. Six (seven on the 8000B and 8200) Acquisition assembly screws are 0.312 inch long. Three Acquisition assembly screws are 1.750 inch long. The 1.750 inch screw locations are marked on the circuit board.

- c. Disconnect the one SMB connector that is connected to the trigger hybrid, located on the front edge of the Acquisition circuit board.
- d. Disconnect two coaxial cables from J8 and J16, located on the Acquisition circuit board.
- e. Disconnect coaxial cable from J5, located on the Acquisition circuit board (8000B only). See Figure 4-32, page 4-51.
- f. Disconnect J10 ribbon cable connector from the J930 processor board.
- g. *Orient the instrument:* Set the instrument so its front panel surface is facing you. Push the module slot covers in to access the slot connectors and attaching hardware.



CAUTION. Note the locations of the T-10 Torxdrive screws and the $\frac{3}{16}$ inch hex threaded posts for later reassembly. Make sure you reinstall the Torxdrive screw and threaded posts in the correct position. The $\frac{3}{16}$ inch hex threaded posts have etched lines around their mounting holes. Interchanging the threaded posts with the Torxdrive screws could cause damage to your module connector. See Figure 4-29 for hardware locations.



CAUTION. Do not interchange the small and large sampling module threaded posts. The large slot sampling module threaded posts are single threaded posts and the small slot sampling module posts are double threaded posts. Installing the double threaded posts into the large module slot could damage the large module connector.

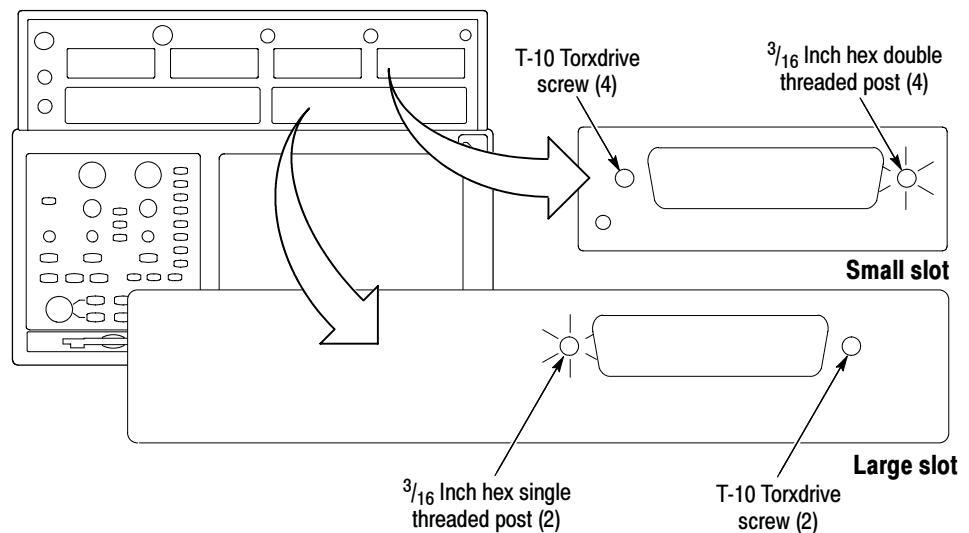

Figure 4-29: T-10 screws and threaded posts

- h.** Remove the four $\frac{3}{16}$ inch hex threaded post from each small module slot.
- i.** Remove the four T-10 Torxdrive screws from each small module slot.
- j.** Remove the Torxdrive screw retaining the circuitry thermal cover. Lift the cover off and remove the $\frac{3}{16}$ inch hex threaded post (8200 only). See Figure 4-30, page 4-49.

NOTE. When reinstalling the thermal cover, make sure that the cover sits in the holding clips.

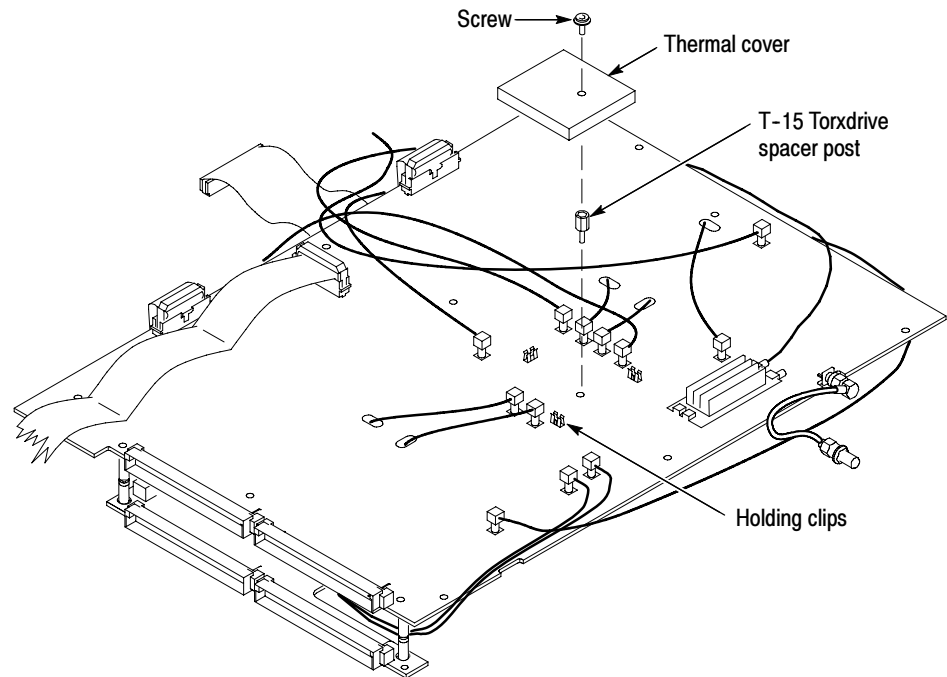

Figure 4-30: Thermal cover removal (8200 only)

- k. Disconnect J6 ribbon cable connector from the large module circuit board.
 - l. Disconnect J5 coaxial cable connector from the large module circuit board.
 - m. Disconnect the three coaxial cables connected to the front panel; INTERNAL CLOCK OUTPUT, DC CALIBRATION OUTPUT, AND EXTERNAL 10 MHz REFERENCE INPUT.
 - n. Disconnect the TRIGGER PROBE POWER ribbon connector from J25 on the Electrical front end board.
 - o. Slide the Acquisition assembly back toward the rear of the instrument then lift up and out of the instrument.
4. *Reinstallation:* Do, in reverse order, substeps h through o.

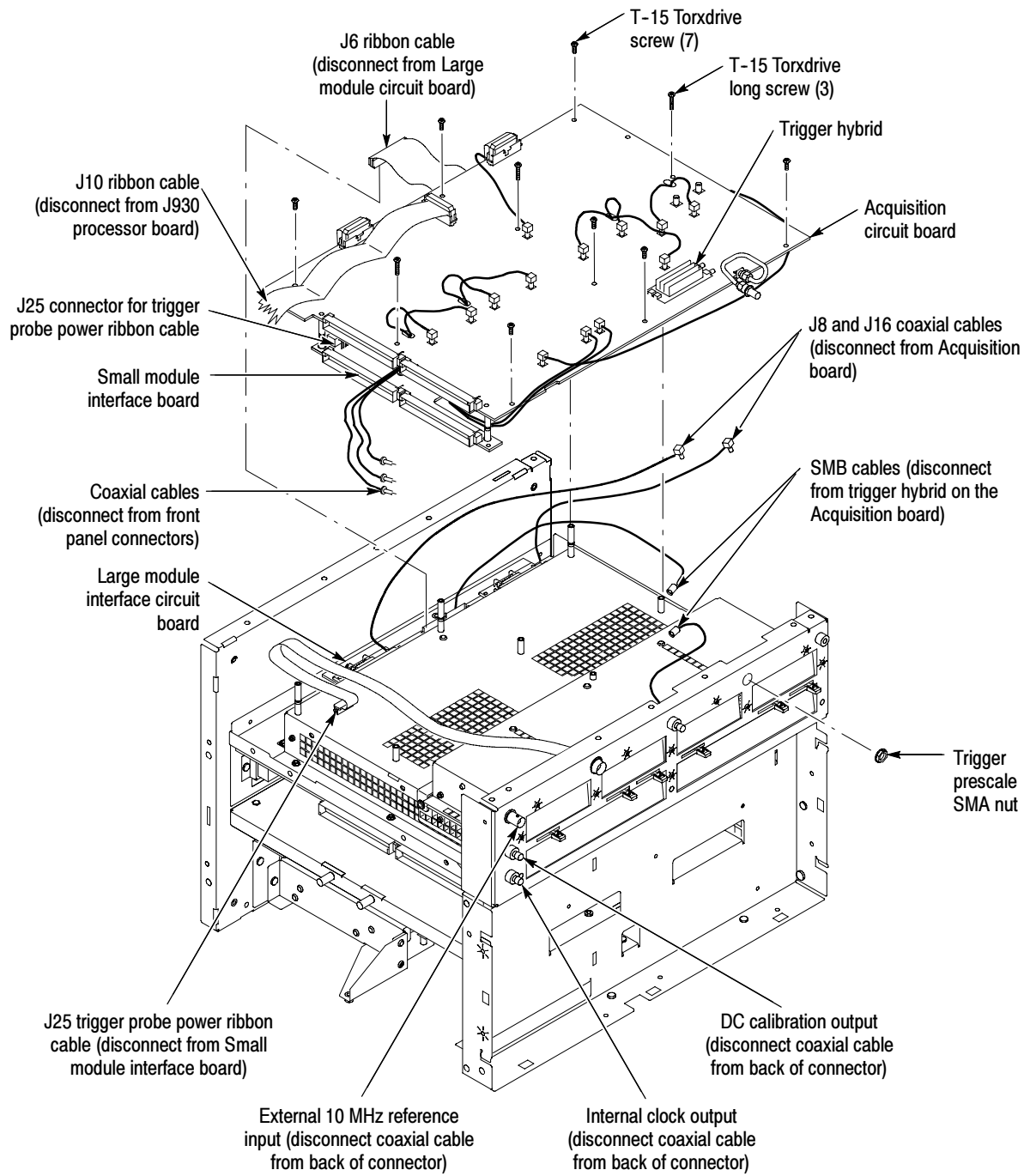

Figure 4-31: Acquisition circuit board assembly removal (8000)

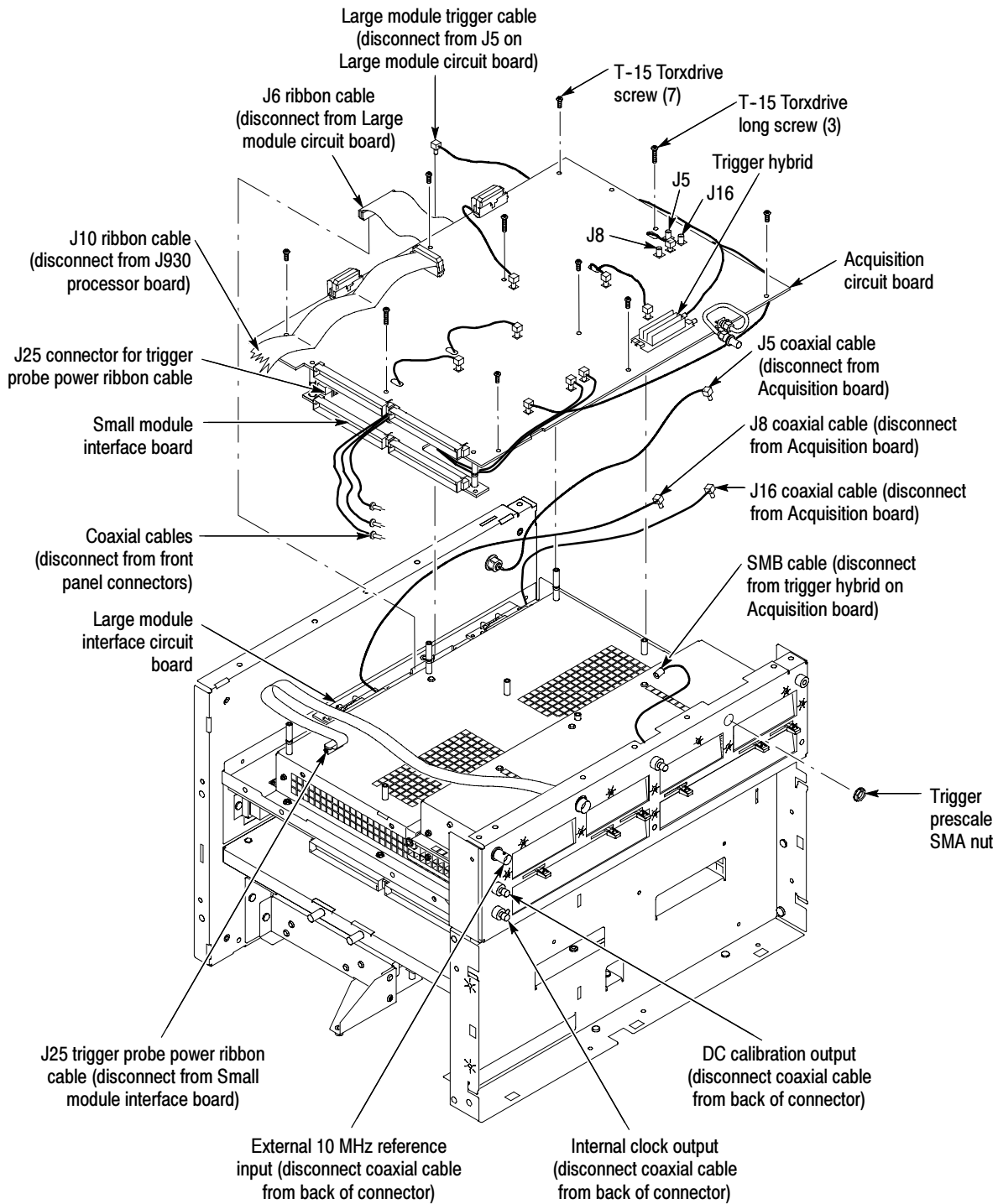

Figure 4-32: Acquisition circuit board assembly removal (8000B)

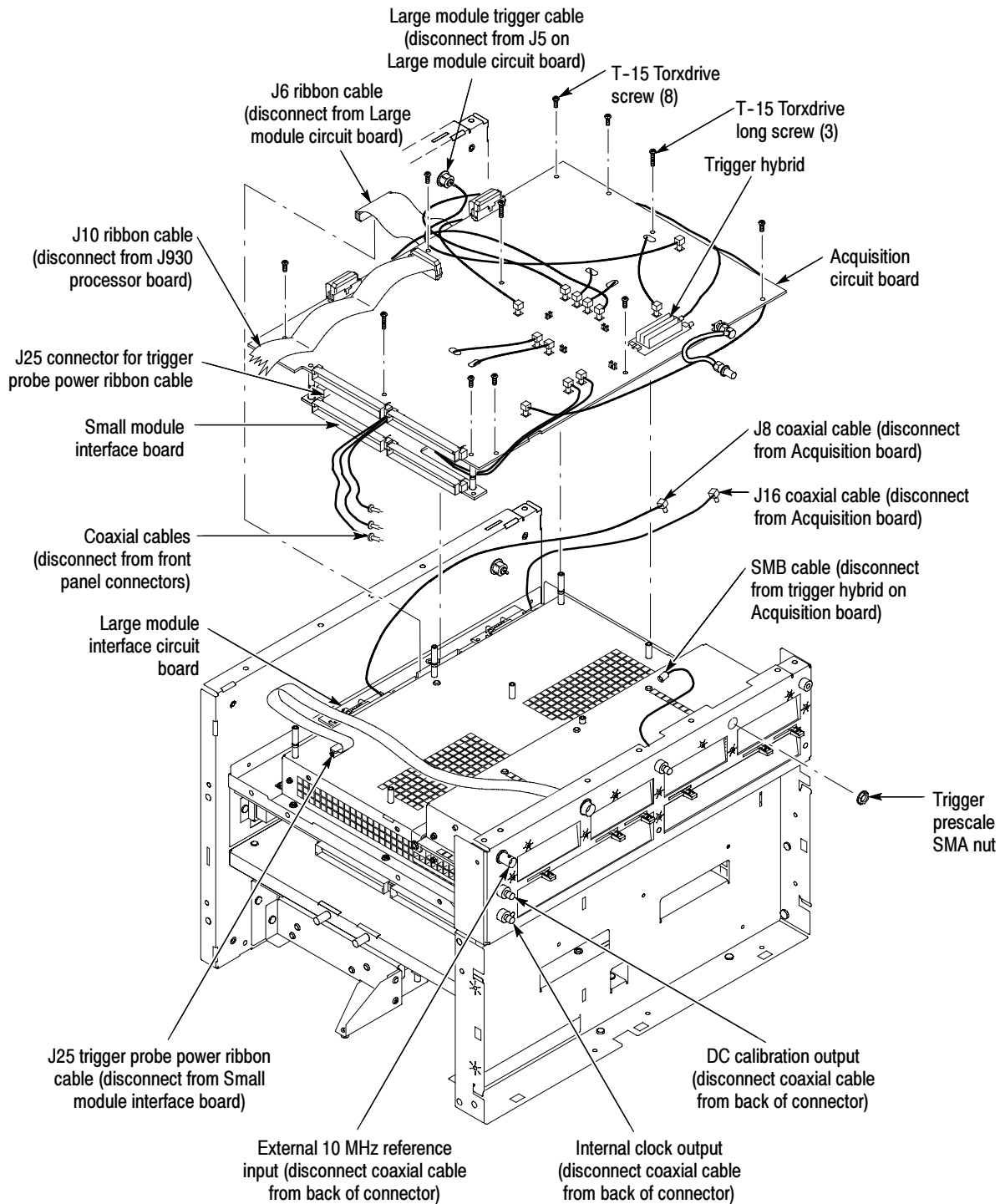

Figure 4-33: Acquisition circuit board assembly removal (8200)

**Large Module Interface
Circuit Board**

1. *Locate module to be removed:* Locate the Large module Interface circuit board in the locator diagram, Figure 4-9, page 4-20. Remove the Large Module Interface circuit board following in this order:
 - Trim
 - Bottom cover
 - Left and Right covers
 - Front and Rear Power Distribution boards
 - Acquisition assembly
2. *Orient the instrument:* Set the instrument so its top is down on the work surface and its bottom is facing you.
3. *Remove the Large Module Interface circuit board:*
 - a. Remove the two $\frac{3}{16}$ inch hex threaded post from each optical module slot. See Figure 4-29, page 4-48
 - b. Remove the two T-10 Torxdrive screws from each optical module slot.
 - c. Remove the T-15 Torxdrive screw located on the Large Module Interface circuit board. See Figure 4-34, page 4-54 (8000 and 8000B) or Figure 4-35, page 4-55 (8200).
 - d. Lift up on the rear of the Large Module Interface circuit board and lift the board out of the instrument.
4. *Reinstallation:* Do, in reverse order, substeps a through d.

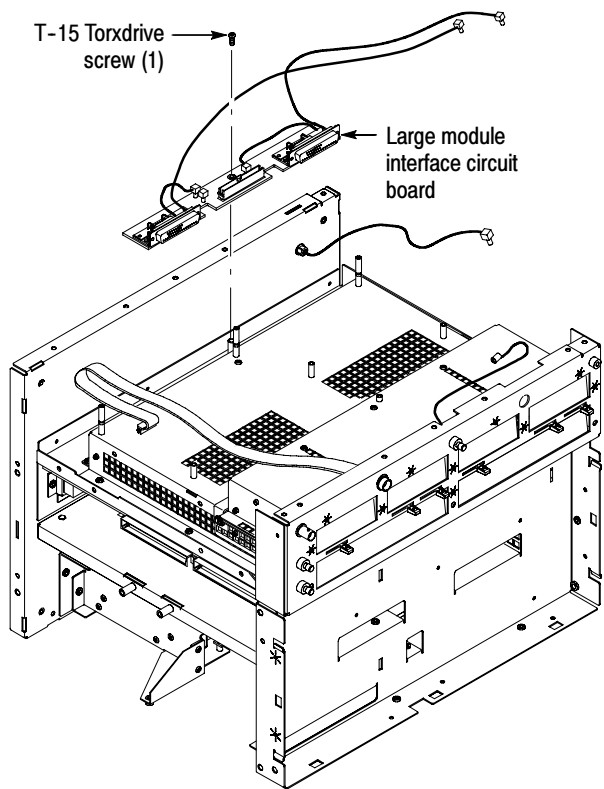

Figure 4-34: Large module interface circuit board removal (8000 and 8000B)

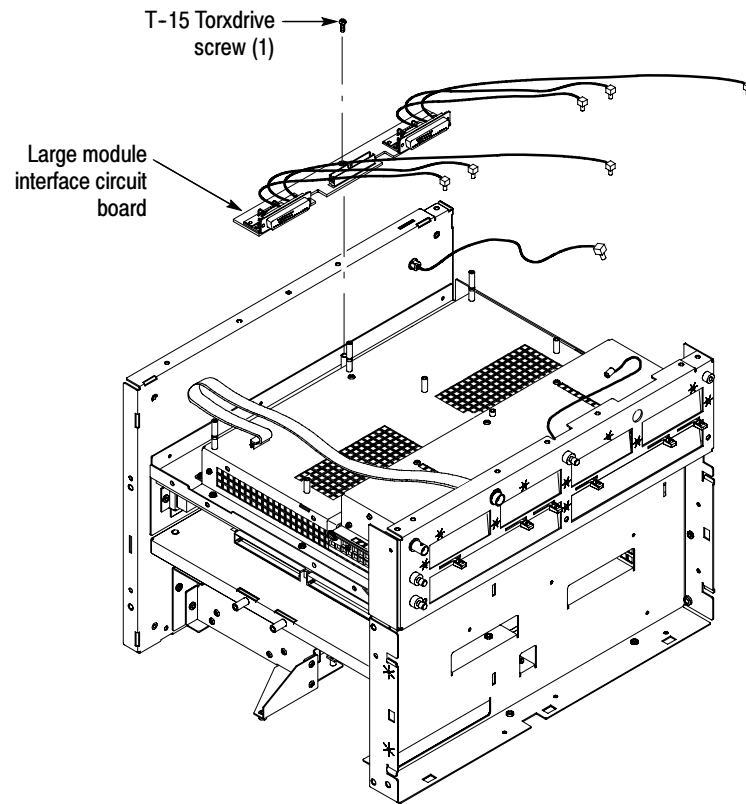

Figure 4-35: Large module interface circuit board removal (8200)

Module Slot Doors

1. *Assemble equipment and locate modules to be removed:* Locate the Module Slot Doors in the locator diagram. Figure 4-9, page 4-20. Additional modules to be removed:
 - Trim
 - Bottom cover
 - Left and Right covers
 - Front and Rear Power Distribution boards
 - Acquisition assembly
2. *Orient the instrument:* Set the instrument so its top is down on the work surface and its front is facing you.

3. *Remove the small module chassis:* See Figure 4-36, page 4-57.
 - a. Remove the nine T-10 Torxdrive screws from front panel.



CAUTION. *One of these Torxdrive screws secures a $\frac{5}{16}$ inch hex nut and grounding lug to the inside chassis. When removing the top right T-10 Torxdrive screw, make sure this ground nut is retained for later reassembly. See Figure 4-36, page 4-57.*

- b. Remove the seven $\frac{5}{16}$ inch hex nuts that secures the small module chassis to the instrument.
 - c. Lift the chassis up and out of the instrument.
4. *Remove the large module chassis:* See Figure 4-36, page 4-57.
 - a. Remove the four T-10 Torxdrive screws from the front panel.
 - b. Remove the eleven $\frac{5}{16}$ inch hex nuts that secure the optical module chassis to the instrument.
 - c. Remove all the snap-on ejector lever handles.
 - d. Lift the back of the chassis up over the studs, then slide the chassis to the rear and out of the instrument.

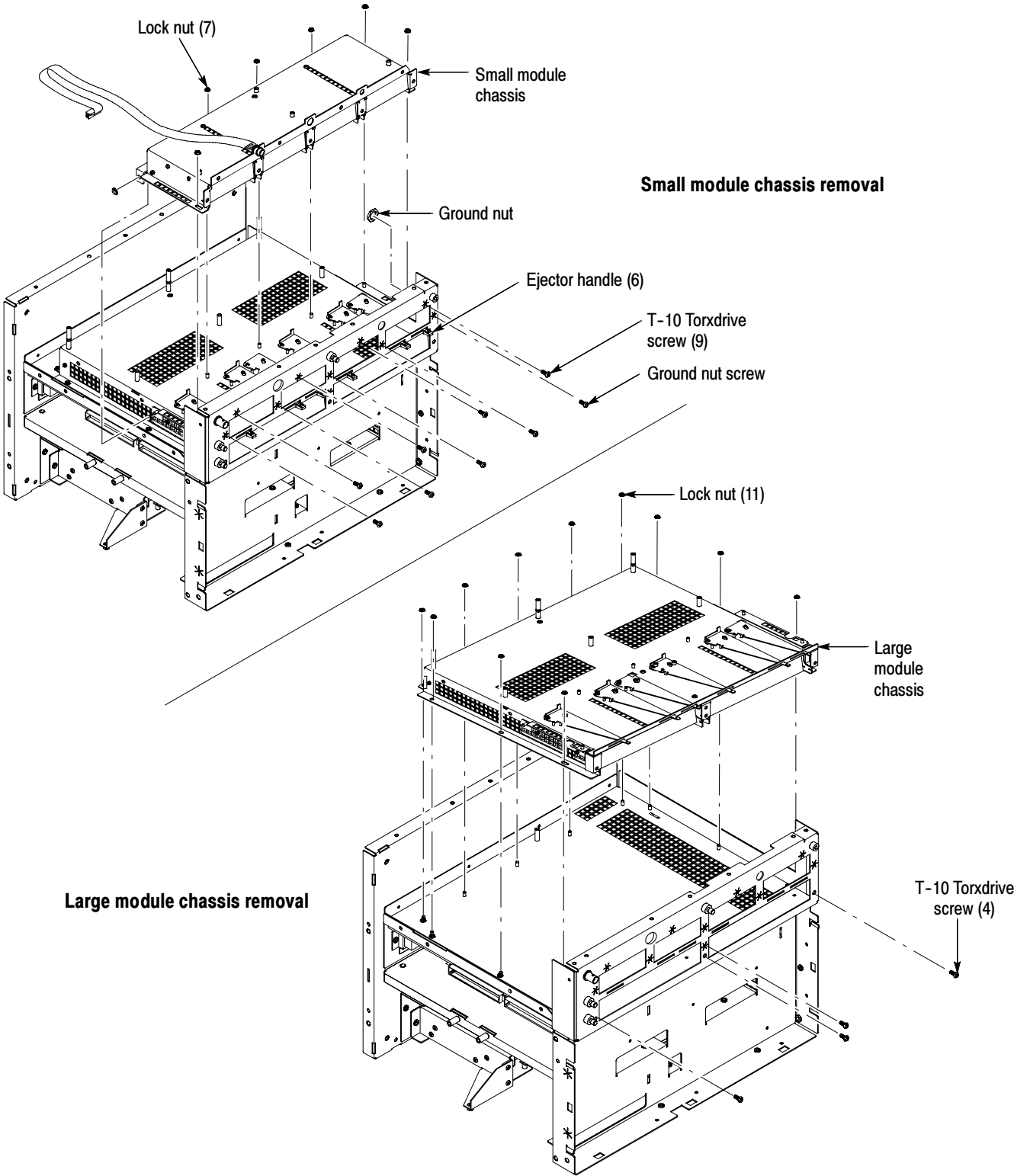

Figure 4-36: Small and Large module chassis removal

5. *Remove the module slot doors:* See Figures 4-37 and 4-38, pages 4-59 and 4-60.
6. *Orient the small or large module chassis:* Set the chassis so the module slot cavities with springs and slot guides are facing you.
 - a. Remove both slot door springs by prying the spring arm from the small slots located on the sides of the module slot. Use a pair of tweezers to pull the spring arms out from the slot.

NOTE. *There is a right and left spring, note locations of the springs for later reassembly.*

- b. Push the module slot door slightly in while lifting the door out of the chassis.

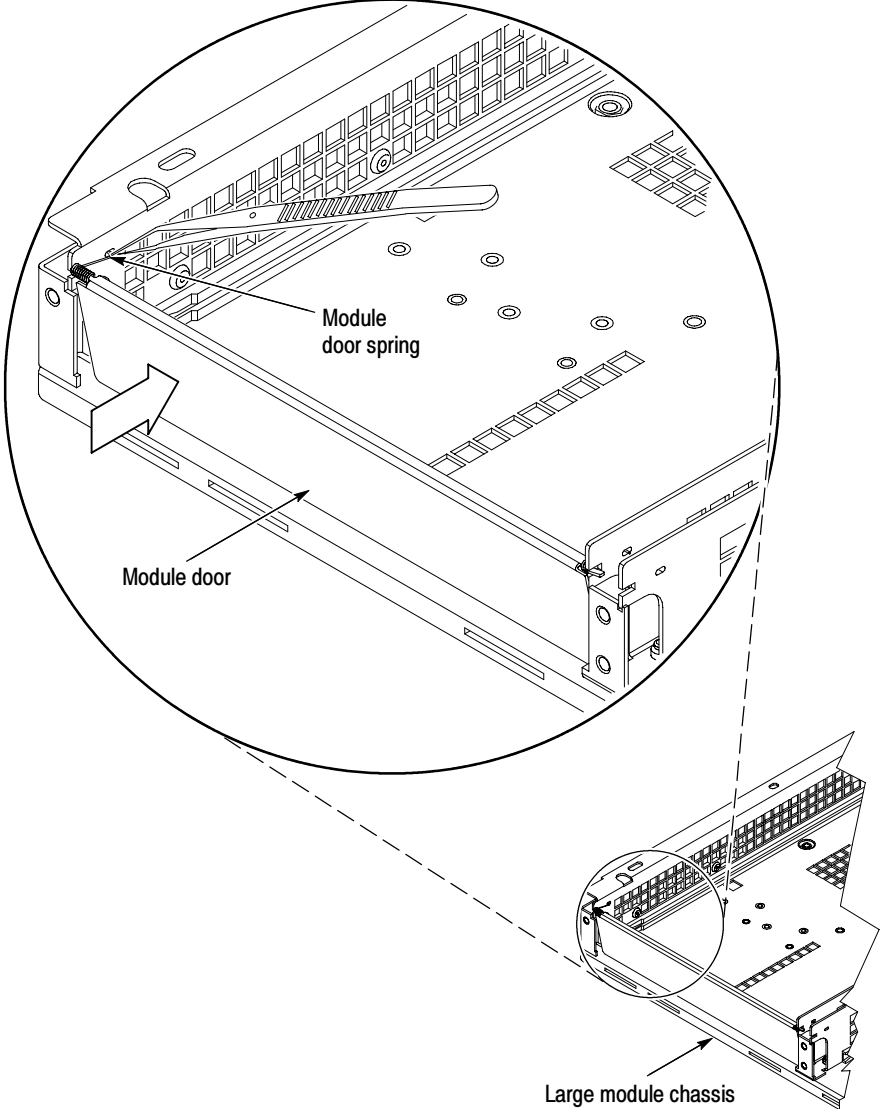

Figure 4-37: Module door spring removal

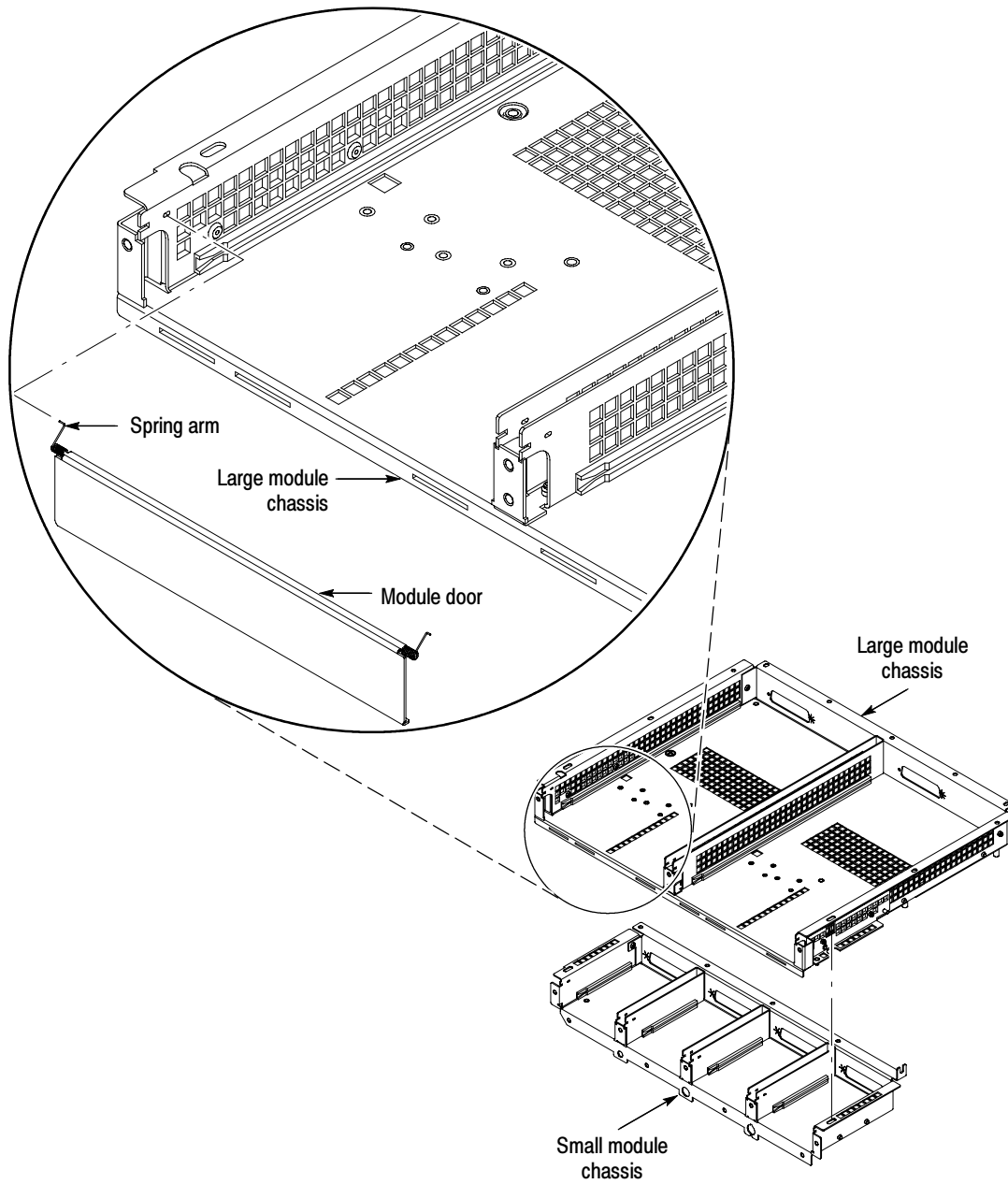

Figure 4-38: Module slot door removal

7. *Remove the module ejector levers:* See Figures 4-39 and 4-40, pages 4-62 and 4-63.
8. *Orient the small or large module chassis:* Set the optical chassis so the module ejector levers are facing you.
 - a. Remove both T-10 Torxdrive screws that secure the ejector lever to the optical chassis.
 - b. Remove both brass washers, ejector lever and ejector spring.
9. *Reinstallation:* Perform the following procedure to reinstall the ejector levers and module slot doors.
 - a. Place the ejector spring over the pem nut standoffs (pivot and slider). One spring arm is positioned next to the ejector lever spring tab. The other spring arm is positioned to the left-side of the stud post.
 - b. Place the ejector lever over the ejector spring and pem nut standoffs (pivot and slider).

NOTE. *Make sure the ejector lever is positioned correctly. The ejector lever has a dimple protruding to accommodate the snap-on handle. When installing the ejector lever this dimple must be facing up from the optical chassis. See Figure 4-39, page 4-62.*

- c. Place brass shoulder washers over both pivot and slider mounting positions.
- d. Install both T-10 and Torxdrive screws to secure the pivot and slider mounting positions.
- e. Move the left spring arm to the right-side of the stud post. The right spring arm must be on the left of the lever tab. See Figure 4-40, page 4-63.

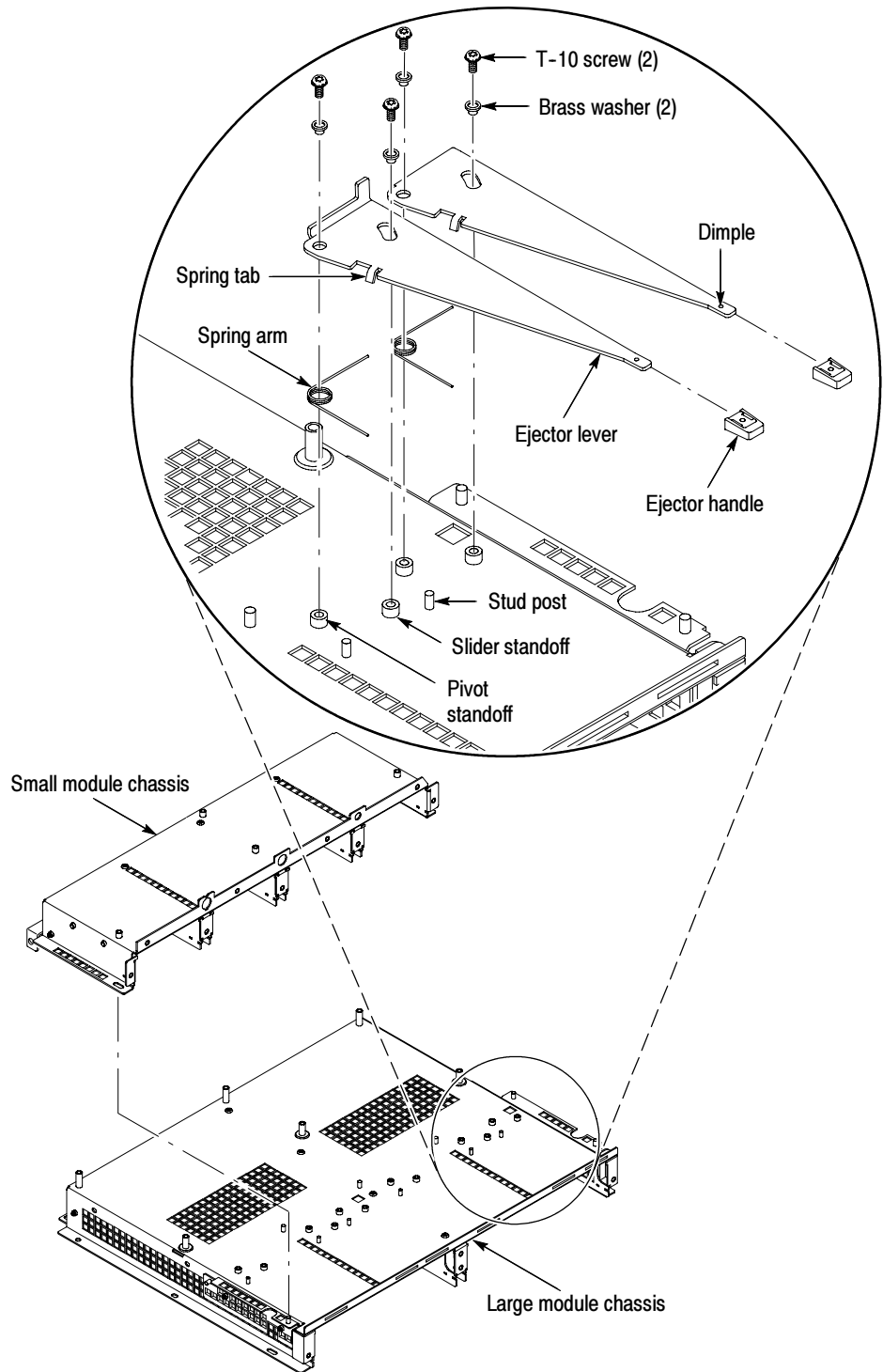

Figure 4-39: Module ejector handles removal

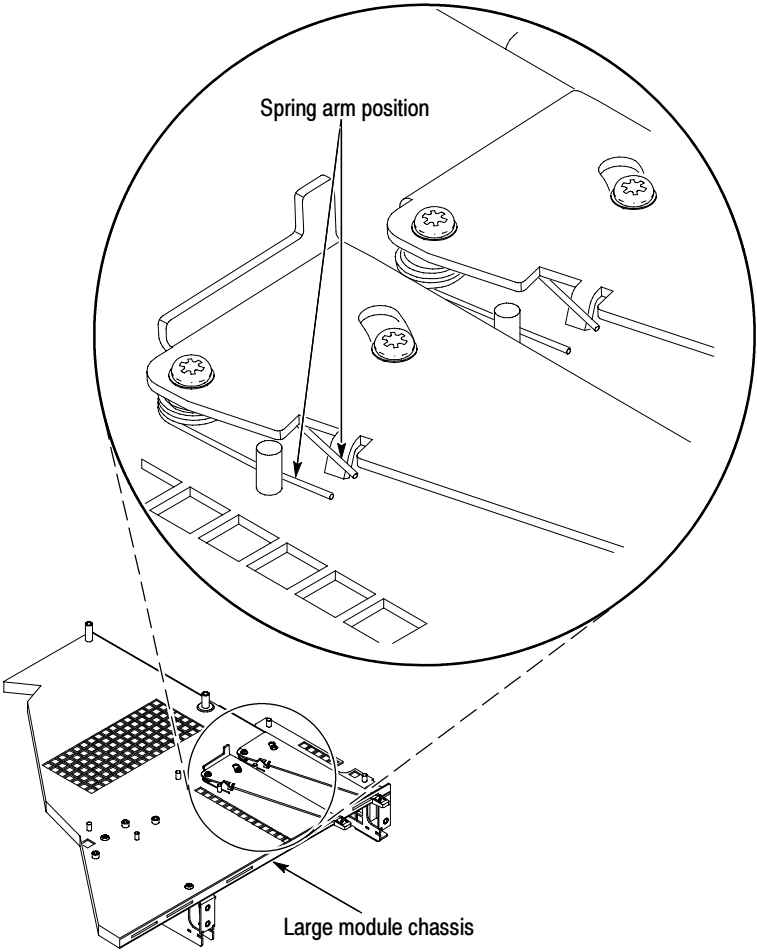

Figure 4-40: Spring arm position

Electrical Modules

1. *Orient the sampling module:* Set the sampling module so its left side is down on the work surface and its right side is facing you.



CAUTION. *Static discharge can damage any semiconductor in the instrument or sampling module. To prevent damage from static discharge wear wrist and foot grounding straps while handling sampling module chassis. Service should be performed in a static-free work station by a qualified service technician. Minimize handling of static-sensitive components.*

2. *Remove the cover:* See Figure 4-41, page 4-64.
 - a. Remove two phillips screws that secure the front panel to the cover. Remove the front panel.
 - b. Remove the four phillips screws that secure the cover to the chassis.
 - c. Slide the chassis out toward the rear of the cover.

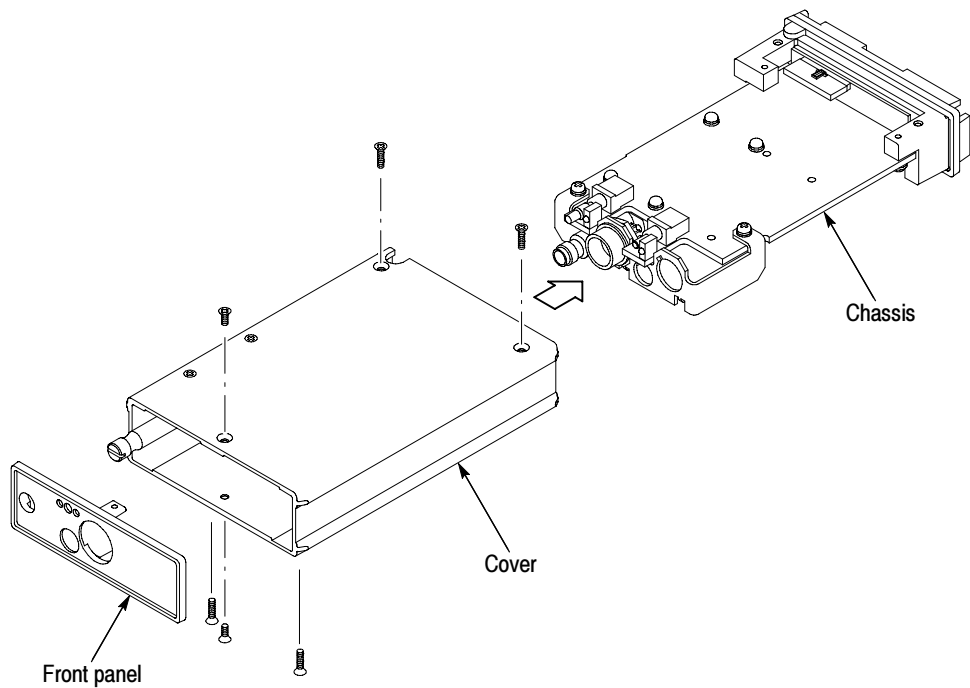

Figure 4-41: Electrical module hardware removal

Exchanging the Electrical Sampling Module

Replacing the sampling module chassis

If it is determined that a sampling module failure is caused by an internal part, you must exchange the complete sampling module chassis to Tektronix. The customer will keep the cover and attaching hardware. Sampling module exchange can be made with either your local Tektronix service center or central Tektronix exchange in Beaverton, Oregon.

1. Transport the chassis sampling modules with terminations on the inputs.
2. Transport the chassis sampling modules in their original containers and store the sampling modules on a metal or conductive surface.
3. When handling the exposed chassis sampling module only, do not touch any exposed component on the circuit board. Grasp the exposed module by the edges of the circuit board or the rear or front housings.

Reinstalling exchange module serial number

Program the serial number (printed on the sampling module cover) into the new replacement sampling module chassis.

1. Reinstall the chassis into the cover following the procedure on page 4-64.
2. Install the electrical sampling module into one of the instrument's slots.
3. Connect a GPIB cable to the GPIB port of the instrument connect the remaining end to the GPIB port of a PC.



CAUTION. Do not have any user interface dialogs active. Dialogs such as Compensation, System properties will prevent the instrument from responding to GPIB commands.

4. Enter the following GPIB commands:
 - a. SYSTem:PROTect OFF
 - b. SYSTem:PROPerties:CH(1-8):SERialnum <serialNum_string>

Example: SYST:PROP:CH3:SER "B010123"

NOTE. For a 2 channel sampling module either channel can be specified in step b. For an 80E01 sampling module use only the lower numbered channel number such as CH1 or CH3.

- c. SYSTem:PROTect ON

5. Verify the serial number change: Pull down the **Utility** menu and then select **System Properties, Sampling Modules**. Click on the channel you want to verify, such as **C3** or **C4**. This display will confirm the sampling module serial number.

Optical Modules

1. *Orient the optical sampling module:* Set the optical sampling module so its left side is down on the work surface and its right side is facing you.
2. *Remove the cover:* See Figure 4-42.
 - a. Remove the seven T-10 Torxdrive screws (80C02 has eleven T-10 Torxdrive screws, four T-10 Torxdrive screws on the top cover) that secure the cover to the module chassis.
 - b. Lift the rear of the cover up and slide back about $\frac{1}{2}$ inch, then lift the non-optical connector side up toward the optical connector side.
 - c. Remove the cover from the chassis.
3. *Reinstallation:* Do in reverse steps a through d to reinstall the front panel assembly.

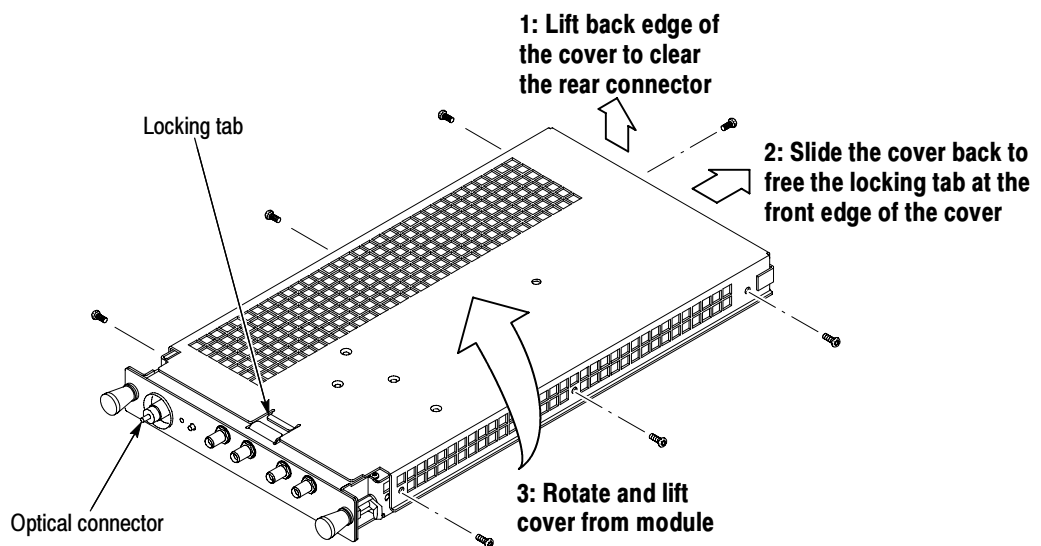

Figure 4-42: Optical module cover removal

80A00 and 82A00 Series Modules

1. *Orient the module:* Set the module so that its left side is down on the work surface and its right side is facing you.

CAUTION. Static discharge can damage any semiconductor in the instrument or sampling module. To prevent damage from static discharge wear wrist and foot grounding straps while handling the module chassis. Service should be performed in a static-free work station by a qualified service technician. Minimize handling of static-sensitive components.

2. *Remove the front panel:* See Figure 4-43, page 4-67.
 - a. Remove two coaxial terminators on the front panel connectors.
 - b. Remove two phillips screws that secure the front panel to the cover. Remove the front panel.

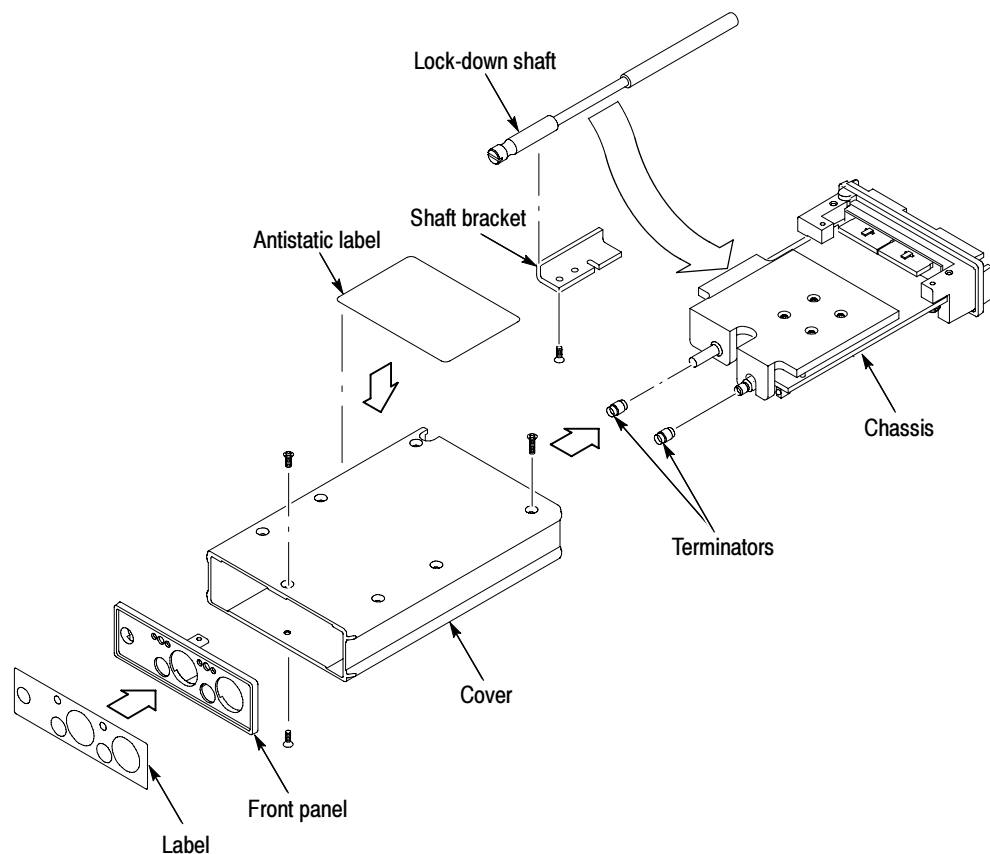

Figure 4-43: 80A00 and 8200 series parts removal (80A01 shown)

- 3.** *Remove the cover:* See Figure 4-43, page 4-67.
 - a.** Remove the six phillips screws that secure the cover to the chassis.
 - b.** Slide the chassis out toward the rear of the cover.
- 4.** *Remove the lock-down shaft and bracket:* See Figure 4-43, page 4-67.
 - a.** Remove the two phillips screws that secure the bracket to its mount. Remove it.
 - b.** Lift out the lock-down shaft.
- 5.** *Reinstallation: Perform steps 2 through 4 in reverse to reassemble the module.*
 - a.** If installing a replacement the front panel, do the following steps before performing step 2:
 - Remove the backing from the front panel label.
 - Align the holes and attach to the front panel.
 - b.** If installing a replacement cover, do the following steps before performing step 3:
 - Remove the backing from the antistatic label.
 - Install the antistatic label to the replacement cover.

Troubleshooting

This section contains information and procedures designed to help you isolate faulty modules in the instrument. If a module needs to be replaced, follow the *Removal and Installation Procedures* located in this section.

Check for Common Problems

Use Table 4-4 to quickly isolate possible failures. The table lists problems related to the instrument and possible causes. The list is not exhaustive, but it may help you eliminate a problem that is quick to fix, such as a blown fuse or loose cable.

Table 4-4: Failure symptoms and possible causes

Symptom	Possible cause(s)
Mainframe will not power on	<ul style="list-style-type: none">■ Power cord not plugged in.■ Failed fuse.■ Faulty power supply.■ Faulty modules.■ Main power switch (rear panel) not on.■ Front panel power switch not on.■ Monitor not connected properly.
Front panel light comes on (mainframe powers on), but one or more fans will not operate	<ul style="list-style-type: none">■ Faulty fan cable.■ Defective fan assembly.■ Faulty power supply.
Mainframe powers on but no signal displayed	<ul style="list-style-type: none">■ Wrong channel is selected, Waveform Selector and Setup menus.■ Module not fully installed into the slot.■ Signal cable not connected properly.■ Wrong trigger input, check signal cable and Setup menus are Direct or Prescale.
Controller appears “dead”; power light comes on, but monitor screen(s) is (are) blank	<ul style="list-style-type: none">■ SO DIMMs incorrectly installed or missing.■ Defective NLX board

Table 4-4: Failure symptoms and possible causes (cont.)

Symptom	Possible cause(s)
Flat LCD panel display blank	<ul style="list-style-type: none"> ■ External monitor plugged in but not powered on. ■ External monitor plugged in (look on external monitor for display). ■ Connect an external monitor cable to the SCOPE ONLY VGA OUT rear panel connector. If monitor has a display, replace the LCD panel assembly. ■ Connect an external monitor cable to the SVGA OUT rear panel connector, if monitor has a display the BIOS may need to be setup. ■ If the BIOS is OK then, replace the Power PC circuit board assembly. ■ Connect an external monitor cable to the SVGA OUT rear panel connector. If the monitor has no display, replace the NLX circuit board assembly. ■ If the monitor has no display when connected to the SVGA OUT rear panel connector, replace the NLX circuit board assembly. ■ Defective cable from front panel board to riser board. ■ Defective cable from Power PC board to front panel board.
Front panel LEDs do not light.	<ul style="list-style-type: none"> ■ Replace the front panel board.
Hard disk drive related symptoms	<ul style="list-style-type: none"> ■ Defective hard disk drive. ■ Incorrect hard disk type selected in the BIOS setup. ■ Replaceable hard disk drive not installed. ■ Power supply failure. ■ Corrupted controller BIOS module firmware, reinstall firmware. ■ Controller BIOS setup problem. See BIOS Settings. ■ Replaceable hard disk drive or optionally field installed fixed hard disk drive not configured as bootable (slave) master hard disk drive. ■ Faulty benchtop controller.
CD-ROM related symptoms	<ul style="list-style-type: none"> ■ Defective CD-ROM. ■ Defective CD-ROM drive cable. ■ Defective CD-ROM board. ■ Incorrect CD-ROM configuration in the BIOS setup.

Table 4-4: Failure symptoms and possible causes (cont.)

Symptom	Possible cause(s)
Diagnostic errors	<ul style="list-style-type: none"> ■ Remove all electrical and optical modules from the instrument, then diagnostics again. If the instrument passes diagnostics, check for the electrical and optical module that is causing the failures. Then run diagnostics again. ■ If the instrument fails the diagnostics without the installed modules replace the Acquisition assembly. The run diagnostics again.
Compensation errors	<ul style="list-style-type: none"> ■ Remove all electrical and optical modules from the instrument, then run compensation again. If the instrument passes compensation, check for the electrical and optical module that is causing the failure. ■ Verify that each module is completely installed into the slot. If the instrument still fails compensation, replace the Acquisition assembly.
Modules not recognized	<ul style="list-style-type: none"> ■ Module firmware incompatible with mainframe software version. ■ Faulty module. Refer to appropriate module service manual for further troubleshooting information. ■ Module not fully installed into the slot.
80C0X modules have no signals displayed	<ul style="list-style-type: none"> ■ Module not fully installed into the slot. ■ Wrong channel is selected, Waveform Selector and Setup menus. ■ Signal cable not connected properly. ■ Replace optical cables. ■ Replace Optical assembly or Acquisition assembly.
80C0X modules; poor noise performance	<ul style="list-style-type: none"> ■ Male fiber-fiber connections need to be cleaned. Refer to Table 4-1 on page 4-3.
80C0X modules; frequency response exhibits a steep negative “droop” in its plot.	<ul style="list-style-type: none"> ■ Bad internal O/E RF amplifier de-coupling. Check tightness of all rigid cable interconnect.
BIOS error messages	<ul style="list-style-type: none"> ■ Refer to the BIOS error message table.
Instrument locks up	<ul style="list-style-type: none"> ■ Power down the instrument, then restart. ■ Replace the NLX assembly. ■ Replace the Power PC circuit board assembly.

Equipment Required

You will need a digital voltmeter to check power supply voltages, as described on page 4-74.

Testing might also be required to correct some faults. Under those circumstances, you will need the test equipment listed in the *Performance Verification and Adjustment Procedures* in this manual.

Isolating Failures between the 80E0X/80C0X Modules or the Mainframe

To determine if the sampling module has failed or the mainframe failed, perform the following:

1. Perform the module compensation. Refer to *Perform the Compensation* on page NO TAG.
2. Perform the measurement procedures you require to make your test.
3. If the the measurement fails, Remove the sampling module and install it into another slot.
4. Perform steps 1 and 2, then take the following action:
 - If the measurement successfully functions, there is a good chance the mainframe channel has failed. Perform other mainframe diagnostics in this section.
 - If the measurement fails, there is a good chance the sampling module has failed. Return to Tektronix, Inc. for repair.

Isolating to a Board if Power Will Not Come Up

If the mains power is on, a red light (see Figure 4-44 for its location) is visible through the right side of the instrument.

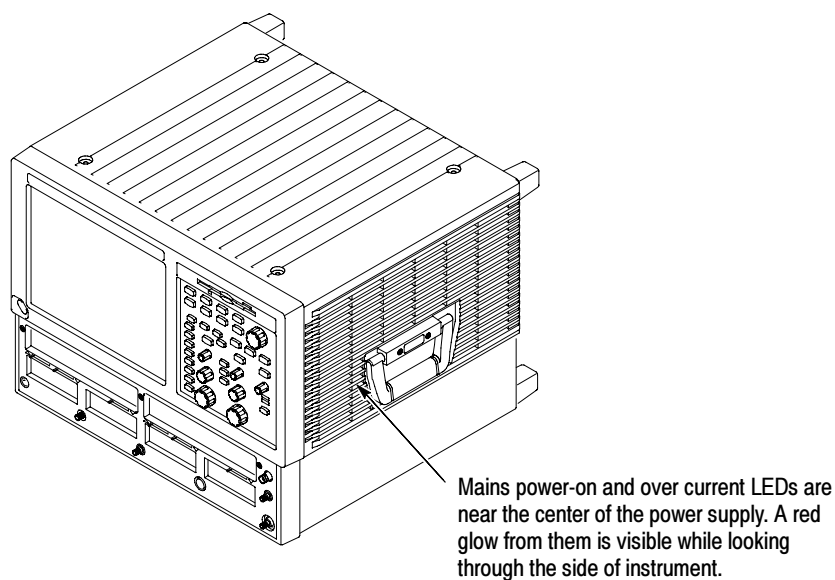

Figure 4-44: Location of power-on and over current LEDs

If the instrument thinks power is on, a red light (see Figure 4-44) means that there is an over current condition.

If the on/standby pin (pin C1 of P201 on the rear power distribution board or pin B162 on the riser board) is low, the instrument thinks power is on.

Remove boards one at a time to locate a fault (the display, floppy, acquisition board, front [analog supply to acquisition board] and rear power distribution boards, the NLX board, and the riser board). If you remove the NLX board, you must jumper the debug power-on pins (see Figure 4-45). The PPC board and the rear power distribution board are required for power to come up.

If removing the boards did not find the problem, replace the power supply.

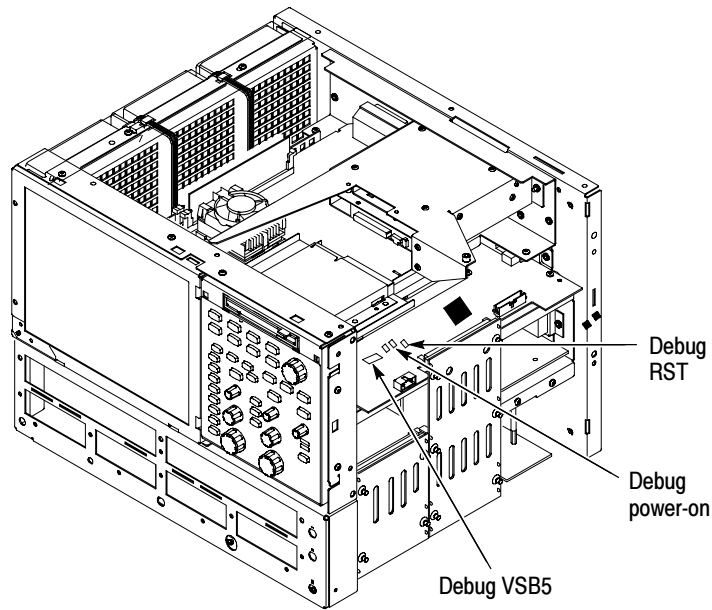

Figure 4-45: Location of debug pins

Checking the Power Supply Voltages

Power off the mainframe and remove any modules installed in it. Power on the instrument and connect the reference lead of a digital voltmeter to chassis ground, such as the top of the power supply.

Attach a 0.025 inch square pin to the probe tip of the other lead and insert it into a pin on one of the connectors. The pins that should be carrying voltages are listed in Table 4-5. The location of the P1 and P2 connectors is shown in Figure 4-46 on page 4-75.

Measure the power supply voltages with the voltmeter and compare each reading to the values listed in the tables. If the voltages are within about 5% of the nominal voltages, your power supply is functional.

Also see *Low-Voltage Power Supply* on page 4-38.

Table 4-5: Power supply voltages

Front power distribution board (P2)	Voltage	Rear power distribution board (P1)	Voltage
Pins A1, B1, C1	+3.3 V	Pins A5, B5, C5	+12 V
Pins A13, B13, C13	-15 V	Pins A8, B8, C8	+5 V
Pins A15, B15, C15	+15 V	Pins A19, B19, C19	+3.3 V
Pins A17, B17, C17 (8000 series only)	-5 V		
Pins A24, B24, C24 (8000 series only)	+5 V		
Pins A17, B17, C17 (8000B series only)	-5.2 V		
Pins A24, B24, C24 (8000B series only)	+5.2 V		

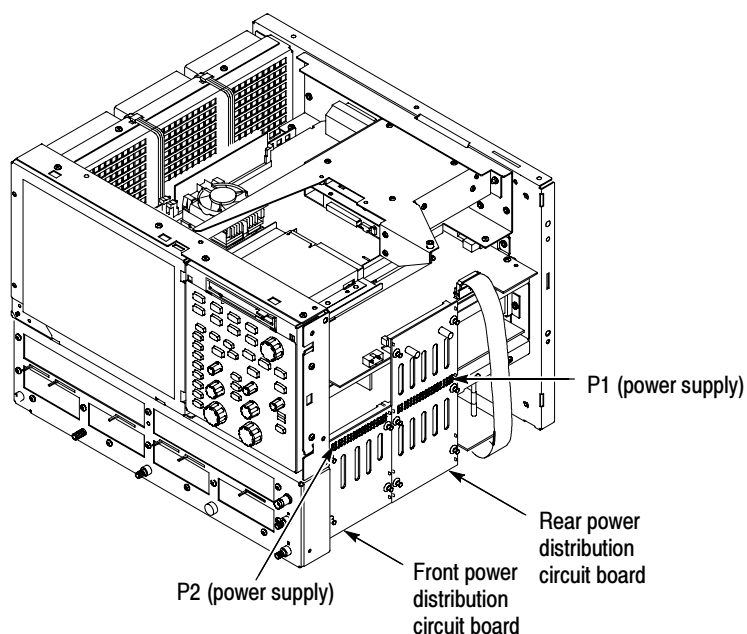

Figure 4-46: Connectors J1 and J2

If the instrument Will Not Boot

If there is a display on the VGA port, but not on the LCD, replace the display assembly (LCD, lamps, and cable).

If nothing is displayed, is the display turned on? At boot time and while using an external monitor connected to the NLX external video port, press F2 to enter the BIOS setup. The Advanced Video Configuration menu lets you select PCI (LCD) or AGP (the NLX port on the rear panel). The lower VGA port on the rear panel is the PCI video port (driven by the same video controller as the LCD).

If none of the above is true, the display adapter may be bad.

Booting Into Windows

If the instrument will not boot, press F8 to enter the start up menu, and boot to the command prompt. If you can boot to the command prompt, use the MSDOS Edit program to edit the autoexec.bat file to run the CMOS restore utility (see *Update/Restore the NLX Board CMOS* on page 4-79).

If booting starts, finds the hard disk, but hangs displaying the Windows splash screen:

1. Select the AGP video port using the setup menu.
2. Disable the busses and disconnect the PPC board by installing J840 and J841.
3. If the system boots (it will only boot to Windows, the instrument application will not run) to the external NLX video port, replace the PPC board.

PPC and NLX PC Diagnostics

The primary diagnostics for the instrument are the power-on diagnostics, the QA+Win32 diagnostics, and the instrument diagnostics. Procedures for running these diagnostics are described below.

Power-On Diagnostics

The power-on diagnostics check the basic functionality of the instrument at every power on. If any failures occur at power on, the screen displays the calibration and diagnostics property page.

The power on tests ensure that hardware is installed and can be accessed by the software. The tests provide limited diagnostic information, but do not provide any performance information. The instrument diagnostics provide more extensive tests than the power-on diagnostics.

The power on tests check the generic hardware including the keyboard, mouse, memory, CPU, and associated peripherals. The interrupt lines and trigger lines are also checked.

QAPlus/Win

If the instrument passes all the BIOS tests and Windows boots, the primary tree calls for you to run QAPlus/Win diagnostics software.

QAPlus/Win is a comprehensive diagnostic software application to check and verify the operation of the PC hardware in the instrument.

To run QAPlus/Win, you must have a working keyboard (a working mouse or other pointing device is optional) and have the Windows operating system running. Repair or replace any failed component identified by QAPlus/Win.

NOTE. To run QAPlus/Win you must have either a working keyboard or a working mouse (or other pointing device) and Windows running.

To run the QAPlus/Win diagnostic software, do the following steps:

1. Exit the instrument application.
 - a. Display the Task Manager by pressing CTRL, ALT, and Delete.
 - b. Select TDS7000 and then touch **End Task**.
 - c. Display the Task Manager by pressing CTRL, ALT, and Delete.
 - d. Select Windowsscopeservices and then touch **End Task**.
2. Exit all other applications and exit all windows.
3. Click Start → Programs → QAPlus_Win → QAPlus_Win.
4. Touch **OK** and select the tests you want to perform.
5. To restore the instrument to normal operating condition, reboot the instrument after QAPlus/Win diagnostic tests are complete.

instrument Diagnostics. If the instrument passes all the QAPlus/Win tests, the primary tree calls for you to run the instrument Diagnostics. The instrument Diagnostics are a comprehensive software test that checks the functionality of the instrument. If the instrument Diagnostics test fails, the instrument is defective.

To run the instrument Diagnostics, do the following steps:

1. Turn off all other applications.
2. From the menu bar, touch **Utilities** and then select **Instrument Diagnostics**.

Diagnostics

The instrument executes a set of internal diagnostics at every power-up. The results can be viewed from the Utilities > Diagnostics dialog. To execute diagnostics Refer to Perform Diagnostics on page to NO TAG.

Firmware Updates

Firmware updates are easy to do. Simply install the firmware CD in your instrument and follow the displayed instructions or the instructions that accompany the CD.

If you want to order a firmware update, contact your Tektronix service center.

After Repair

After removal and replacement of a module due to electrical failure, you must perform the adjustment or software update as indicated in Table 4-6.

Table 4-6: Action required for module replaced

Module replaced	Adjustment required	Software update required
Front panel assembly	No	None
Acquisition board	Yes	Boot ROM and authorization code
PPC processor board	Yes	Boot ROM and authorization code
NLX processor assembly	No	Windows, instrument application
Display panel or display system	No	None
Power supply	Yes	None
Interconnect boards	No	None
Fans	No	None

Installing the Instrument Model and Serial Number

To install a model or serial number into the instrument do the following steps:

1. Connect a PC with a GPIB interface to the GPIB interface of the instrument.



WARNING. Make sure the unique identifier does not end in all zeros before generating or setting the key.

2. Enter the following GPIB commands, if necessary install a new instrument's model number:
 SYST:PROT OFF
 SYST:PROP:MAI:MODE "TDS8000B" or SYST:PROP:MAI:MODE
 "CSA8200"
 SYST:PROT ON

NOTE. Use the correct model number for your instrument, such as TDS8000B or CSA8000.

3. Enter the following GPIB commands, if necessary install a new instrument's serial number:
SYST:PROT OFF
SYST:PROP:MAI:SER <serial number string>, e.g. "B010100"
SYST:PROT ON
4. These commands take effect immediately and can be verified by viewing the mainframe properties: Utilities>System Properties.

Update/Restore the NLX Board CMOS

If the CMOS parameters become corrupted, restore the CMOS memory using the following procedures:



CAUTION. Only install CMOS parameters from Tektronix. CMOS parameters from other manufactures may make your instrument inoperable.

This procedure will allow you to restore the CMOS settings with or without LAN (local area network). Resnet command will restore the CMOS with the LAN disabled. Resnet command will restore the CMOS with the LAN enabled.

If the instrument is running normally or in safe mode:

1. Select Run from the Start menu.
2. From the Run dialog box type one of the following commands:
C:resnet (to enable the network)
C:resnet (to disable the network)
3. Restart the computer, and hold down F2 while it reboots to get into the BIOS Setup Utility menu.
4. In the Bios Setup Utility menu:
 - a. select Advanced, using the right arrow.
 - b. select Peripheral Configuration, using the down arrow.
 - c. press Enter.
5. Confirm the LAN Device configurations:
 - Enabled if resnet was run.
 - Disable if resnet was run.
6. Press CTRL-ALT-DEL to reboot the computer.

Repackaging Instructions

This section contains the information needed to repack the portable main-frame for shipment or storage.

Packaging

When repacking the instrument or sampling modules for shipment, use the original packaging. If the packaging is unavailable or unfit for use, contact your local Tektronix representative to obtain new packaging. Refer to *NO TAG Contacting Tektronix* on page NO TAG for the address, the email address, and phone number.

Seal the shipping carton with an industrial stapler or strapping tape.

Shipping to the Service Center

Contact the Service Center to get an RMA (return material authorization) number, and any return or shipping information you may need.

If the instrument is being shipped to a Tektronix Service Center, enclose the following information:

- The RMA number.
- The owner's address.
- Name and phone number of a contact person.
- Type and serial number of the instrument.
- Reason for returning.
- A complete description of the service required.

Mark the address of the Tektronix Service Center and the return address on the shipping carton in two prominent locations.



Diagrams

Diagrams

This chapter illustrates the electrical operation of the CSA8000 and TDS8000 series instruments and modules using the major circuit blocks.

Symbols

Graphic symbols and class designation letters are based on ANSI Standard Y32.2-1975. Abbreviations are based on ANSI Y1.1-1972.

Logic symbology is based on ANSI/IEEE Std 91-1984 in terms of positive logic. Logic symbols depict the logic function performed and can differ from the manufacturer's data.

The tilde (~) preceding a signal name indicates that the signal performs its intended function when in the low state.

Other standards used in the preparation of diagrams by Tektronix, Inc. are:

- Tektronix Standard 062-2476 Symbols and Practices for Schematic Drafting
- ANSI Y14.159-1971 Interconnection Diagrams
- ANSI Y32.16-1975 Reference Designations for Electronic Equipment
- MIL-HDBK-63038-1A Military Standard Technical Manual Writing Handbook

CSA8000 and TDS8000 Series Block Diagram

Figure 5-1 shows the instrument interconnections between major circuit blocks.

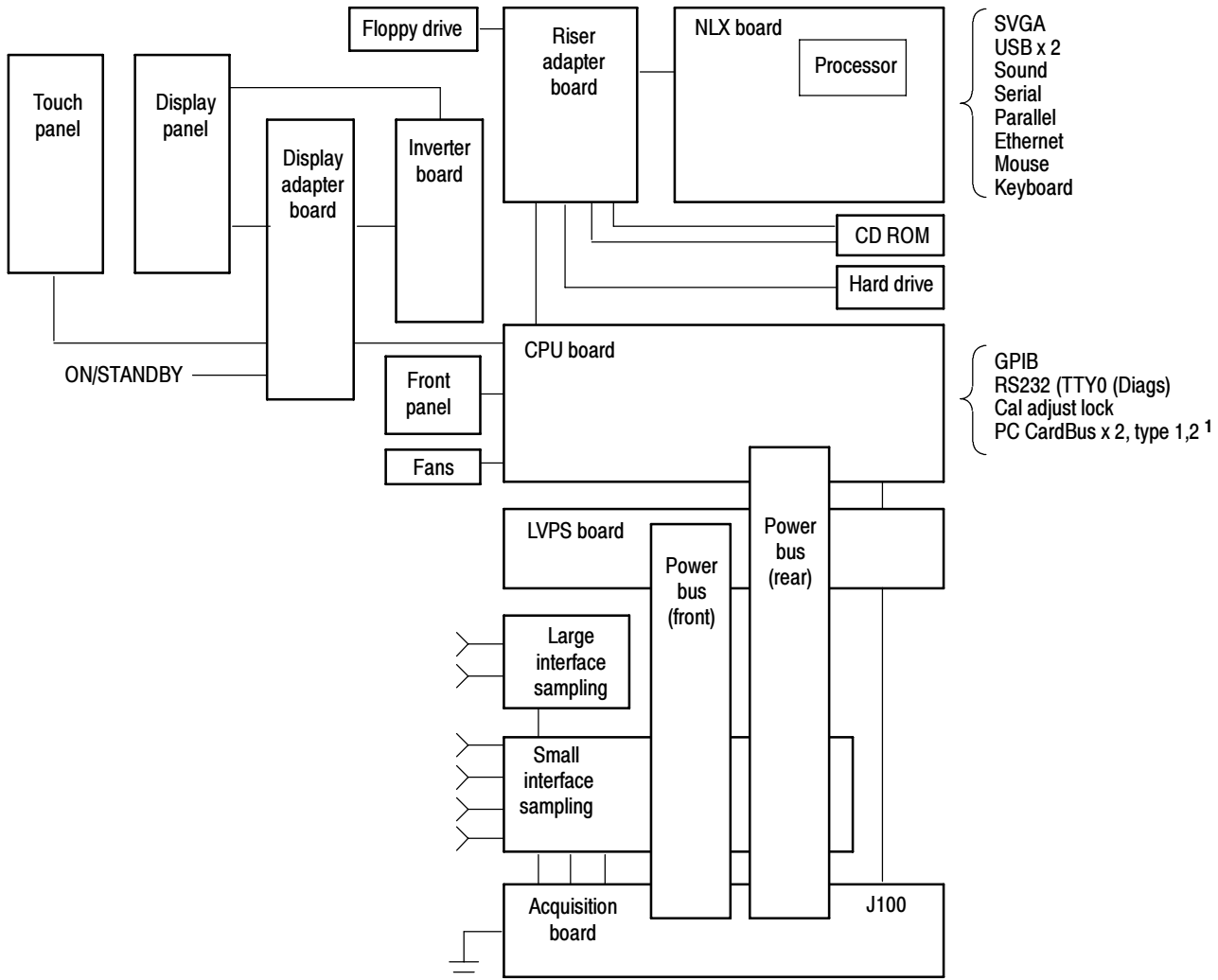

¹ The PC CardBus is not available on the CSA/TDS8000B or CSA/TDS8200 instruments.

Figure 5- 1: Block diagram for CSA8000 and TDS8000 Series Instruments

Electrical Sampling Modules Block Diagram

Figure 5-2 shows the interconnections between major circuit blocks of all electrical sampling modules.

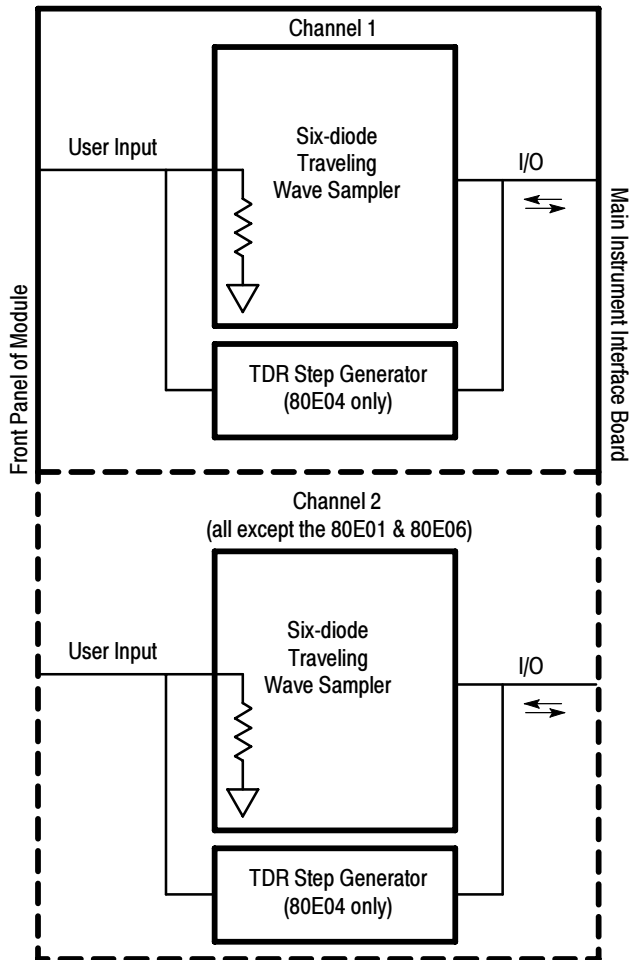

Figure 5-2: Block diagram for the 80E00 Series Electrical Sampling Modules

Optical Sampling Modules Block Diagrams

Figures 5-3 through 5-24 show the interconnections between major circuit blocks of each optical sampling module.

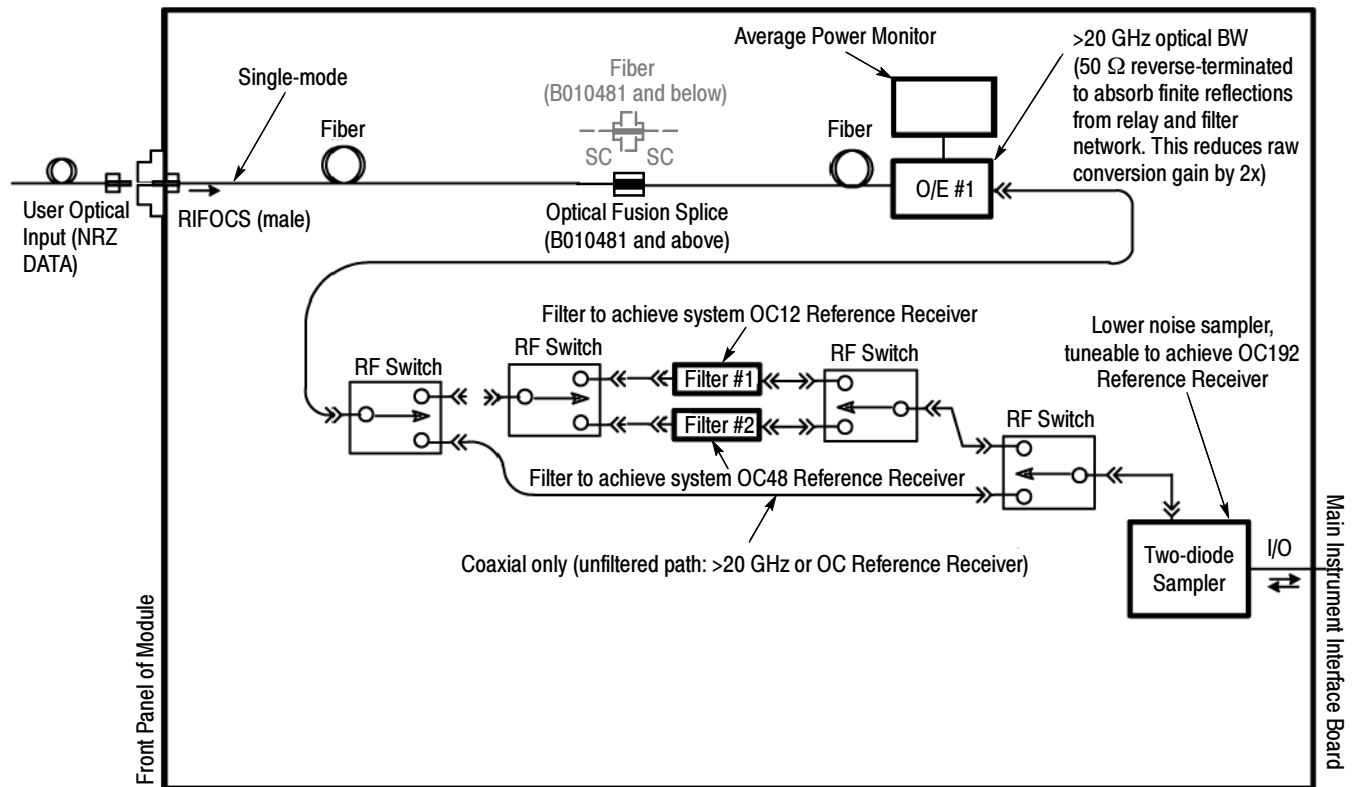

Figure 5-3: 80C01 Optical sampling block diagram

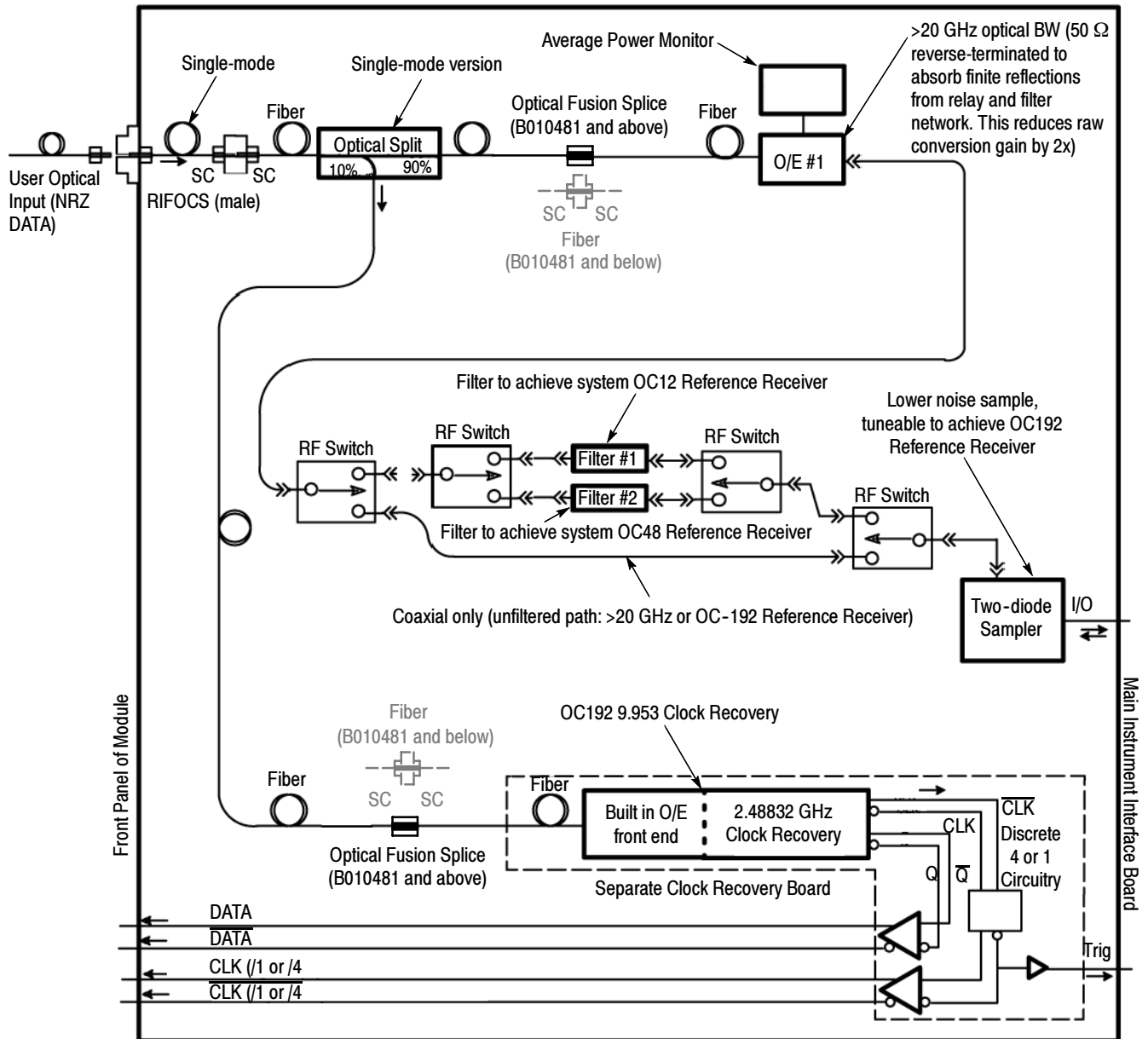

Figure 5-4: 80C01 Optical sampling with clock recovery block diagram

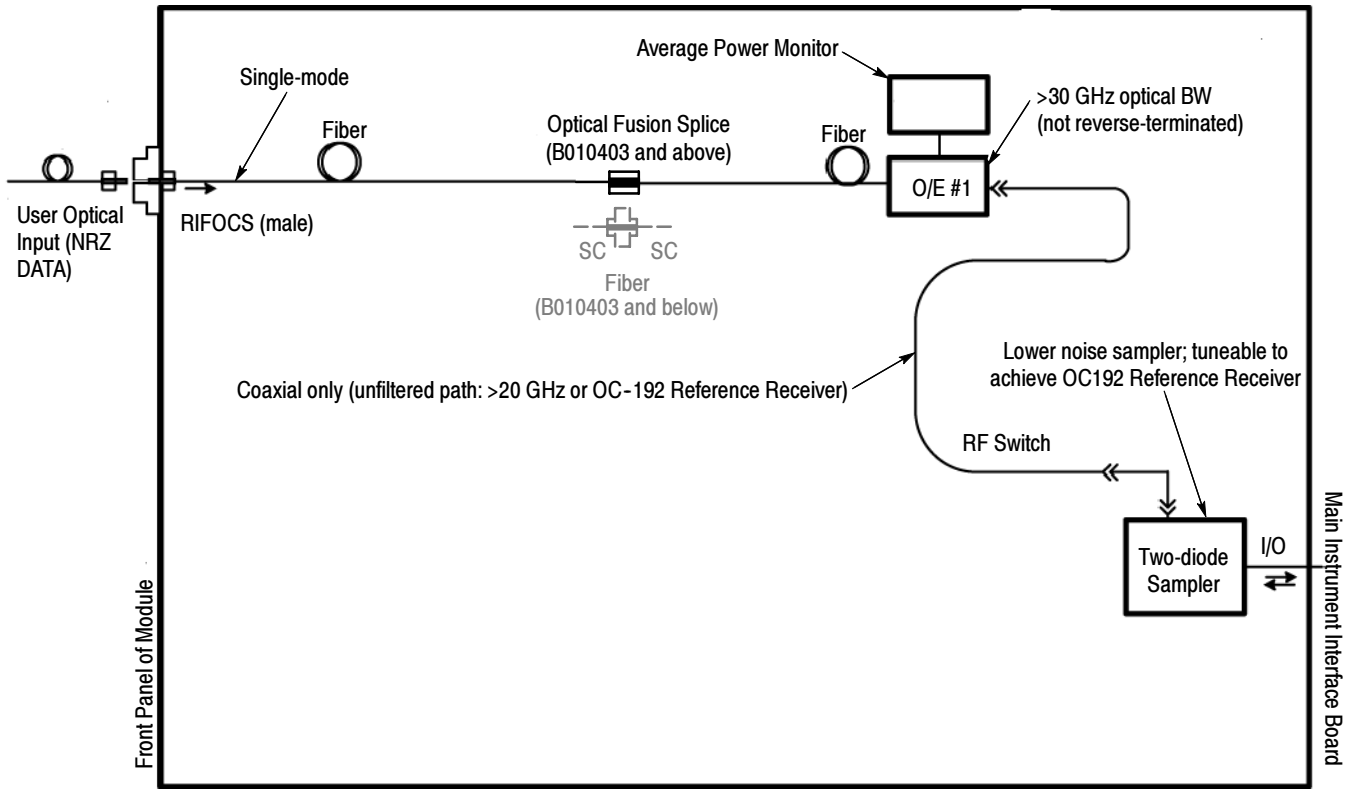

Figure 5- 5: 80C02 Optical sampling block diagram

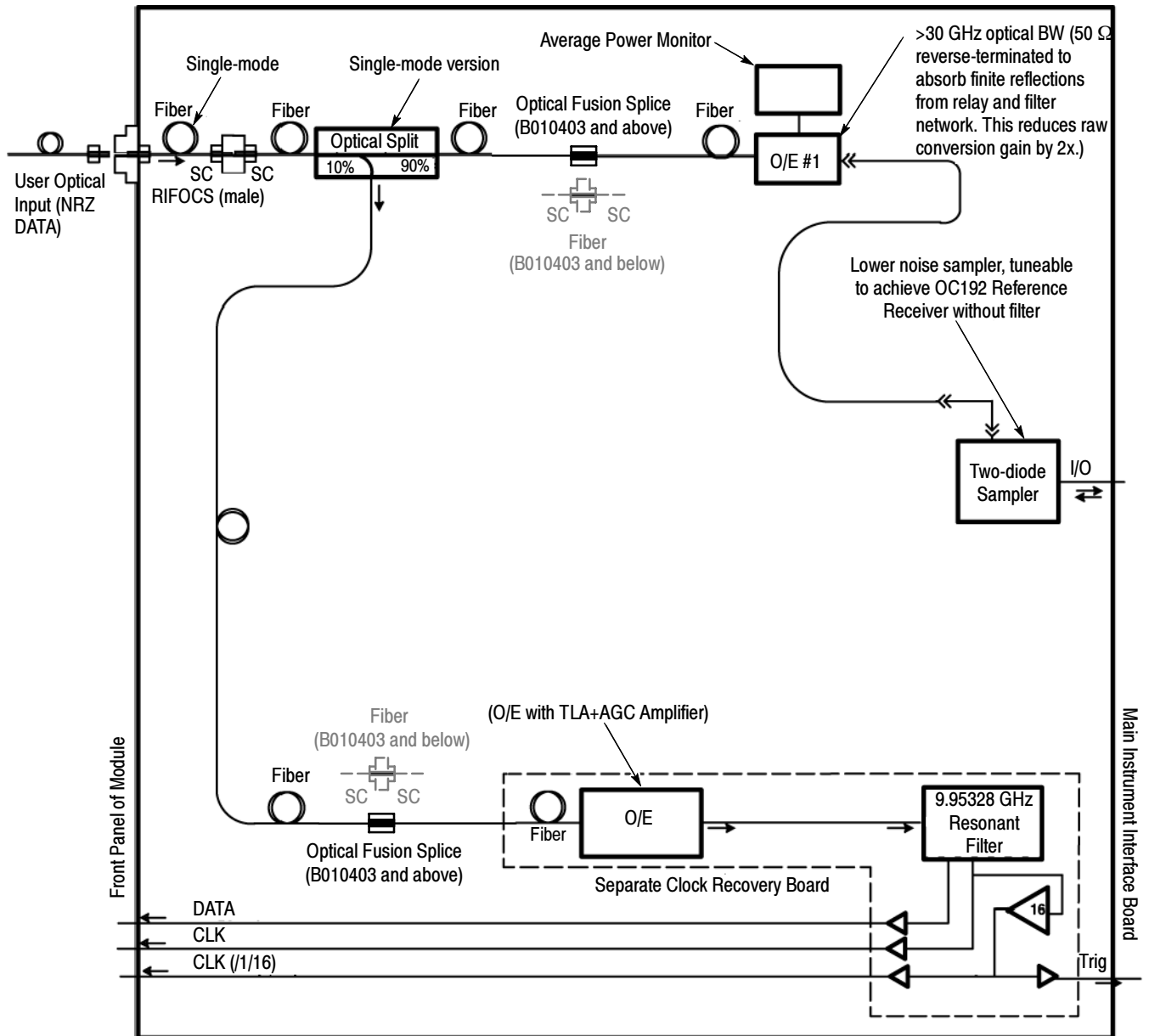

Figure 5-6: 80C02 Optical sampling with clock recovery block diagram

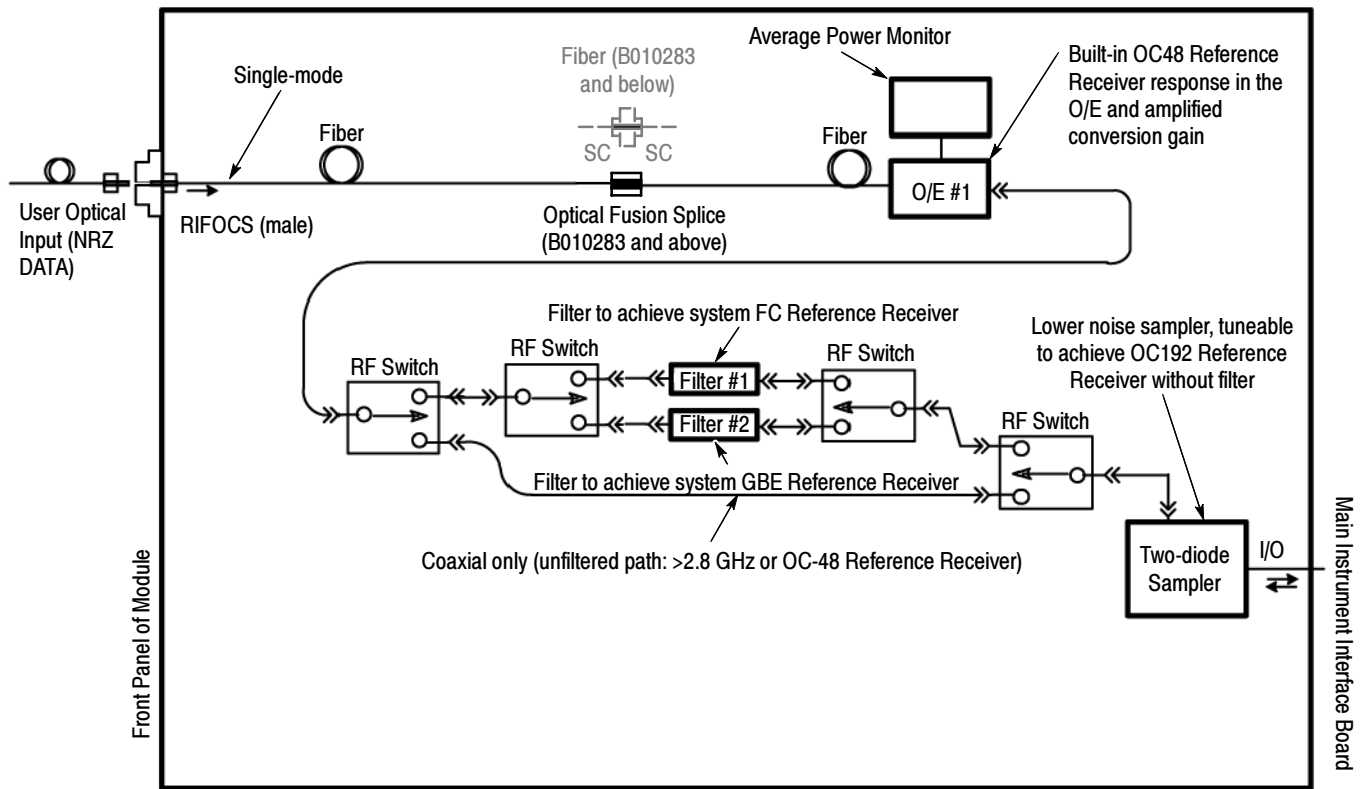

Figure 5-7: 80C03 Optical sampling block diagram

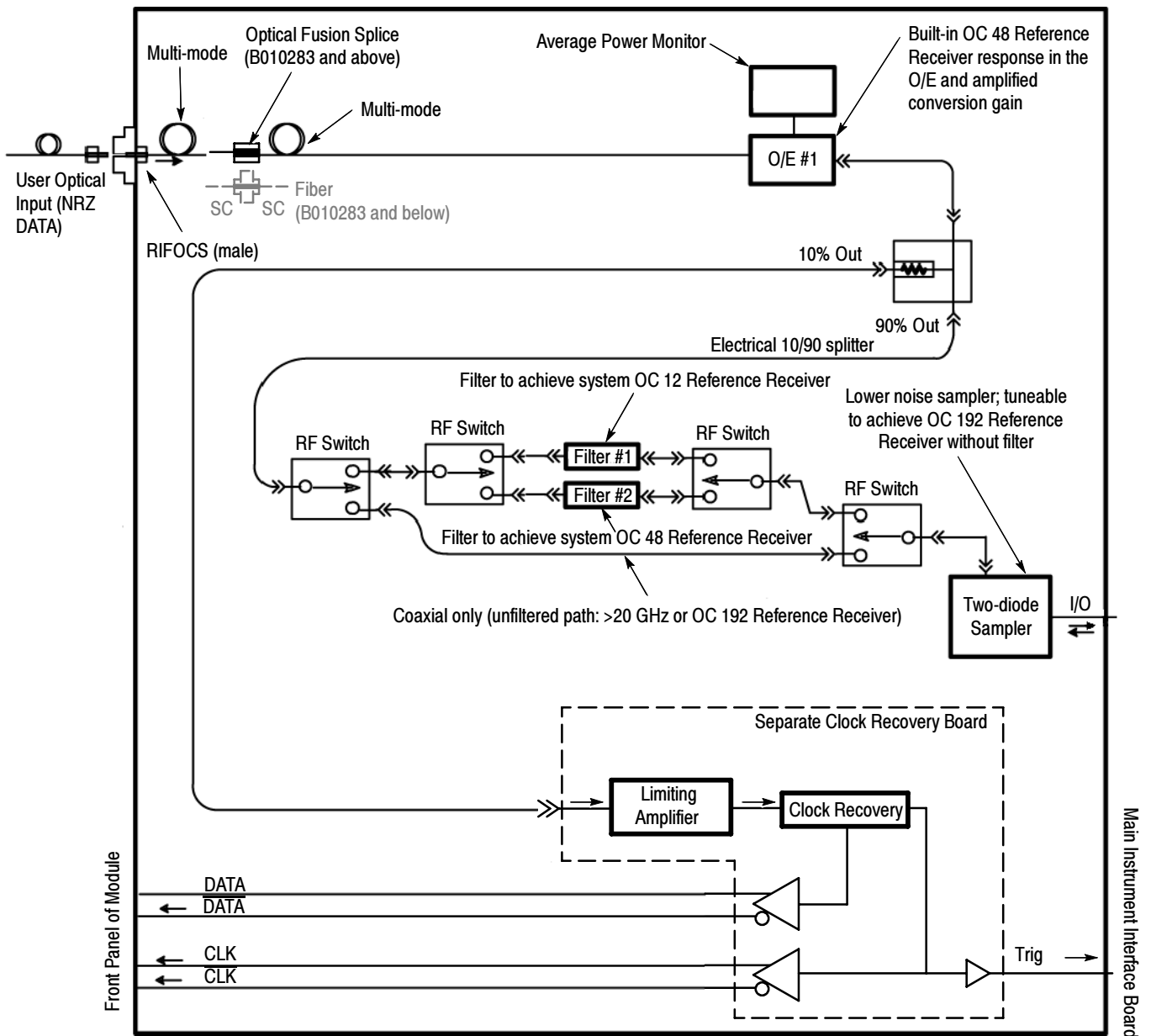

Figure 5-8: 80C03 Optical sampling with clock recovery block diagram

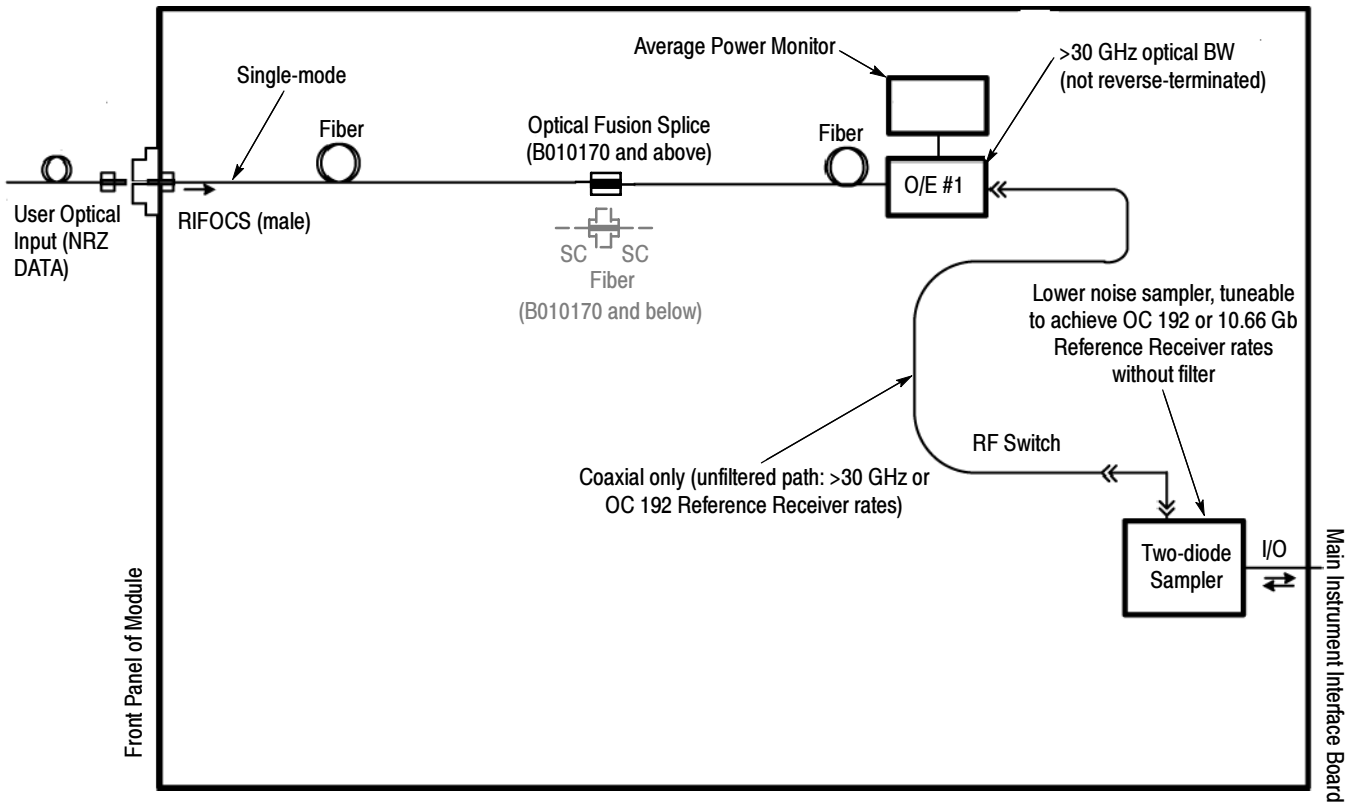

Figure 5-9: 80C04 Optical sampling block diagram

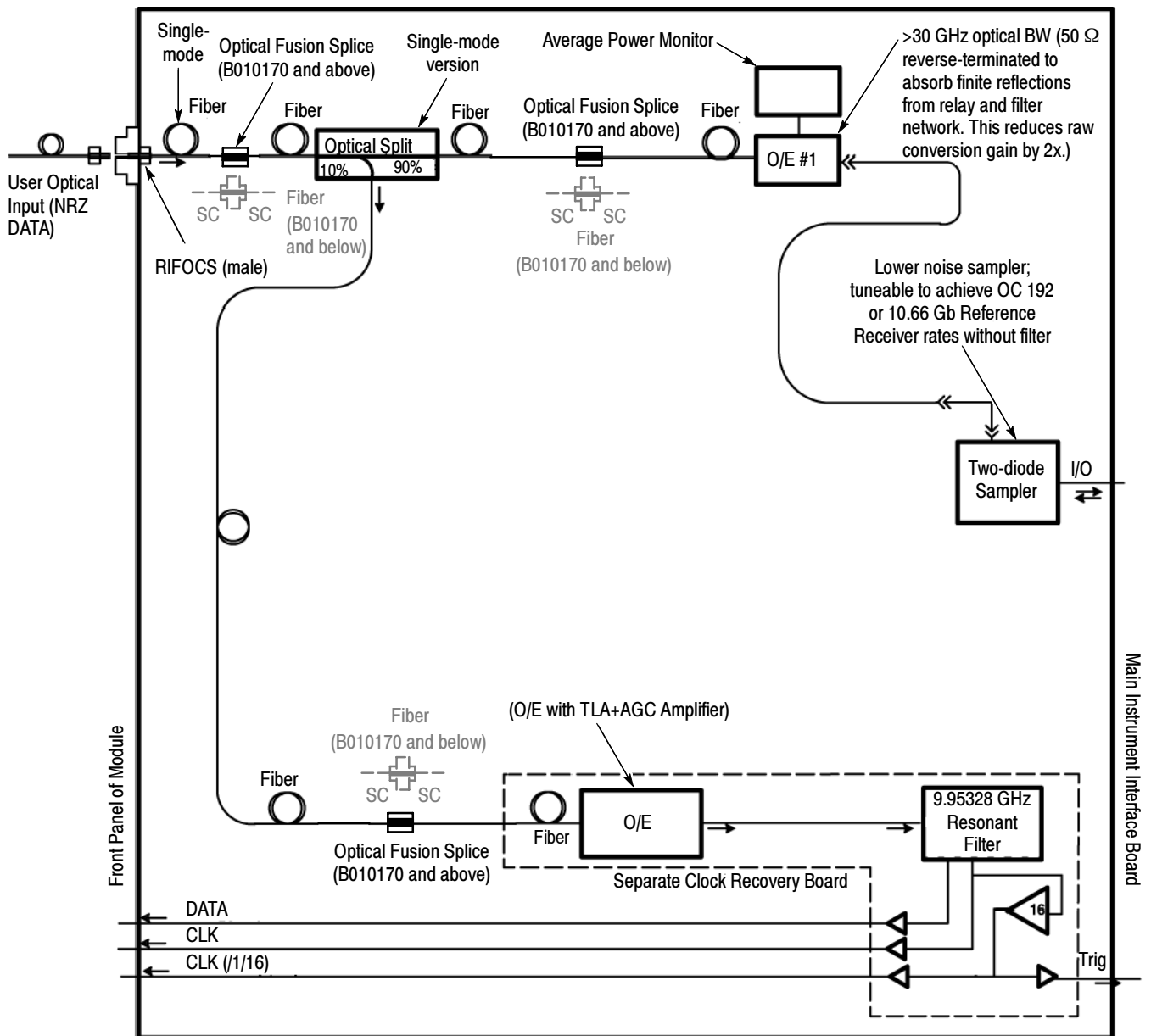

Figure 5-10: 80C04 Optical sampling block diagram with clock recovery

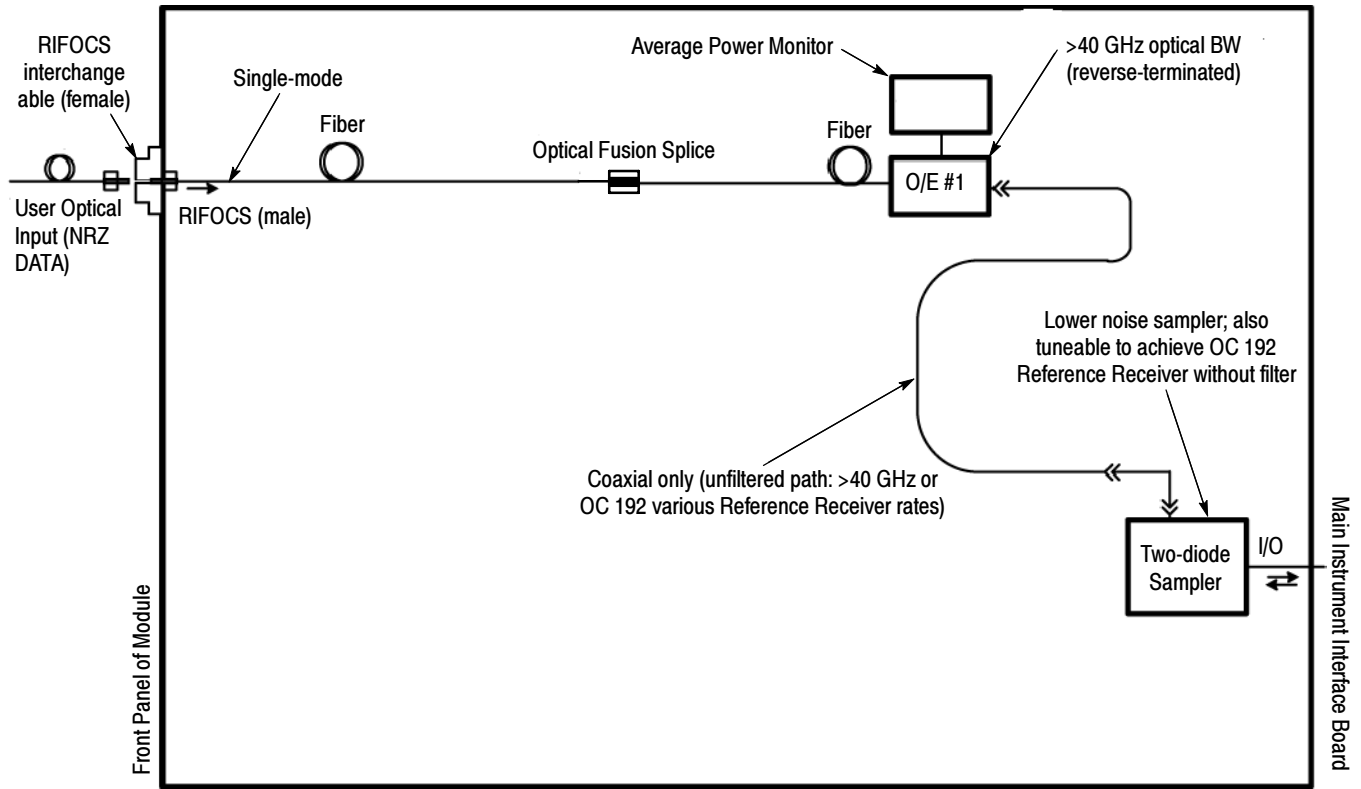

Figure 5- 11: 80C05 Optical sampling block diagram

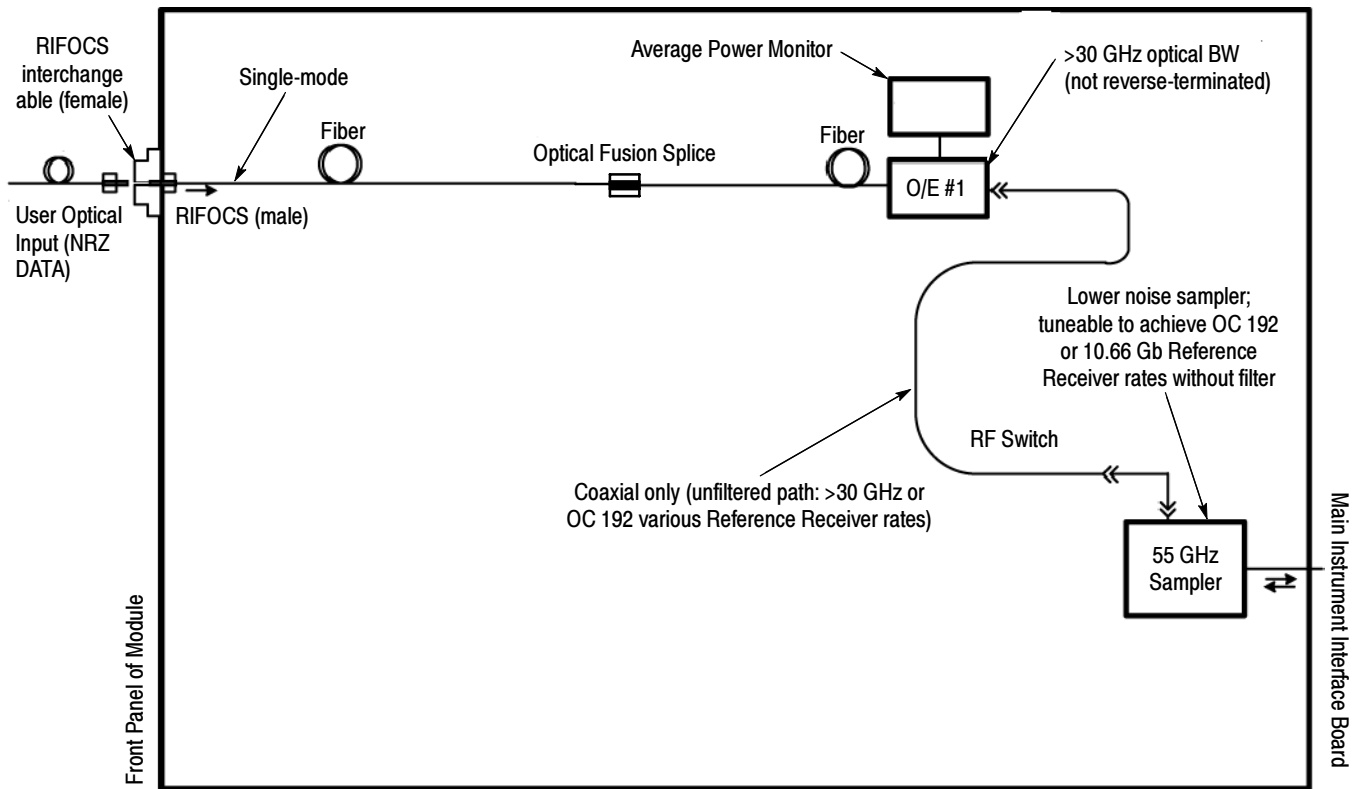

Figure 5-12: 80C06 Optical sampling block diagram

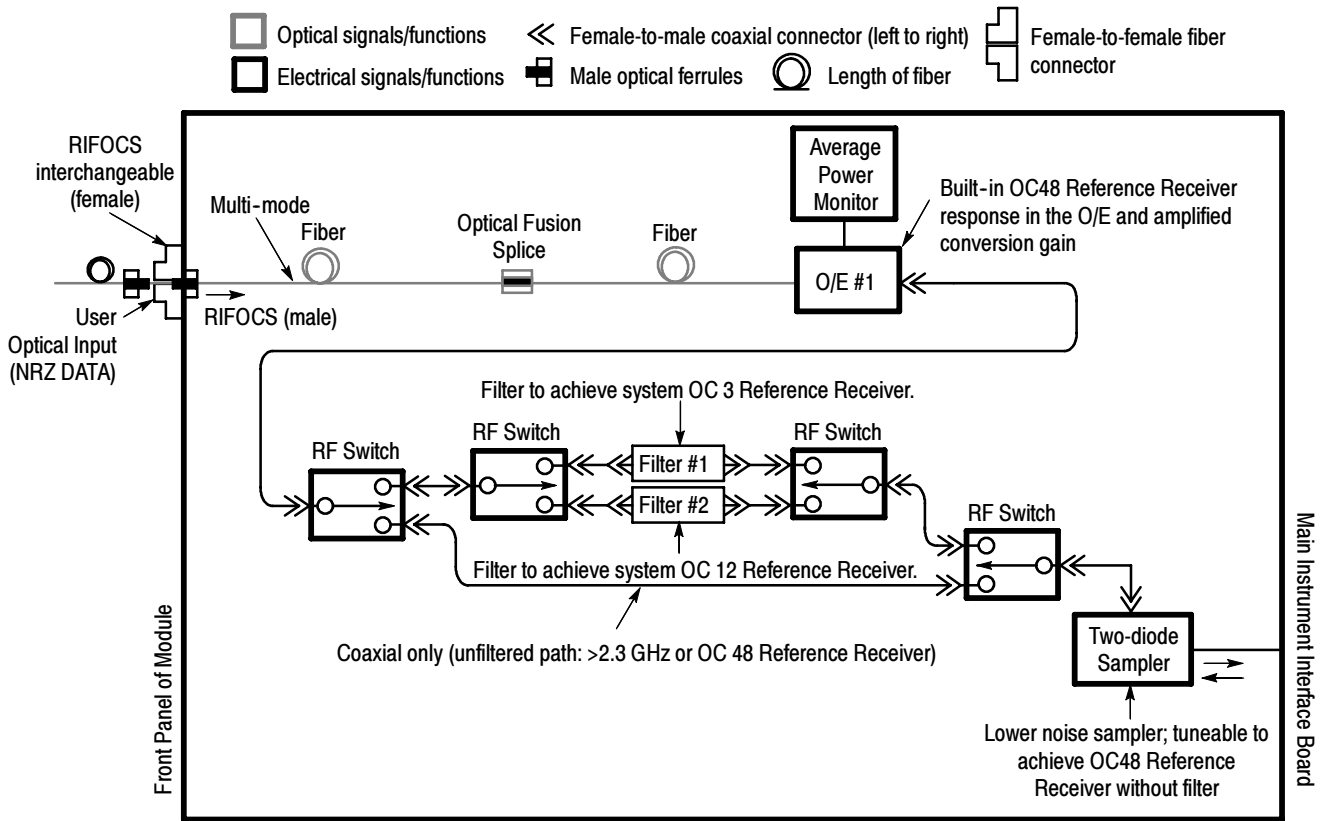

Figure 5- 13: 80C07 and 80C07B Optical sampling block diagram

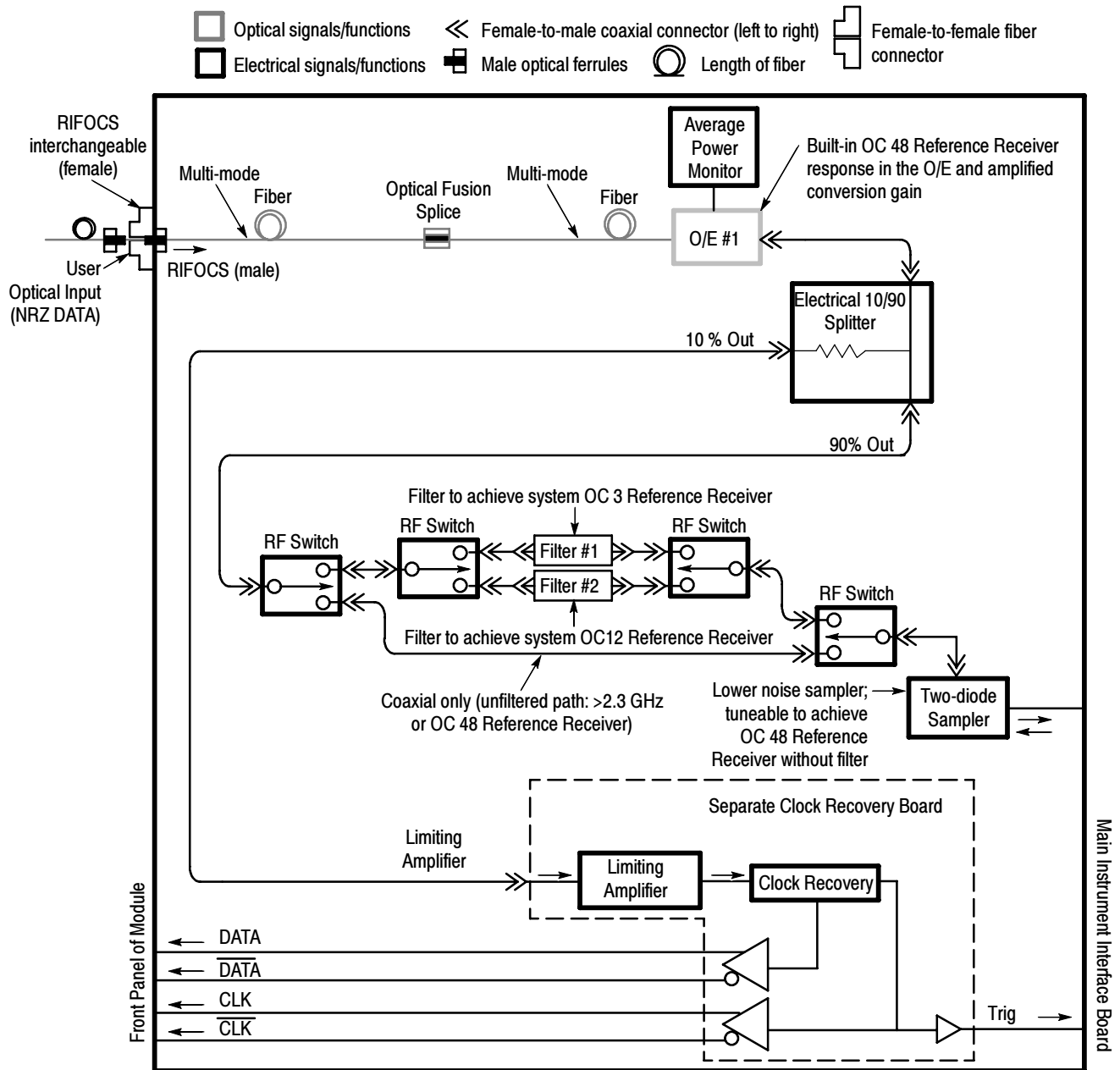

Figure 5- 14: 80C07 and 80C07B Optical sampling with CR1 clock recovery block diagram

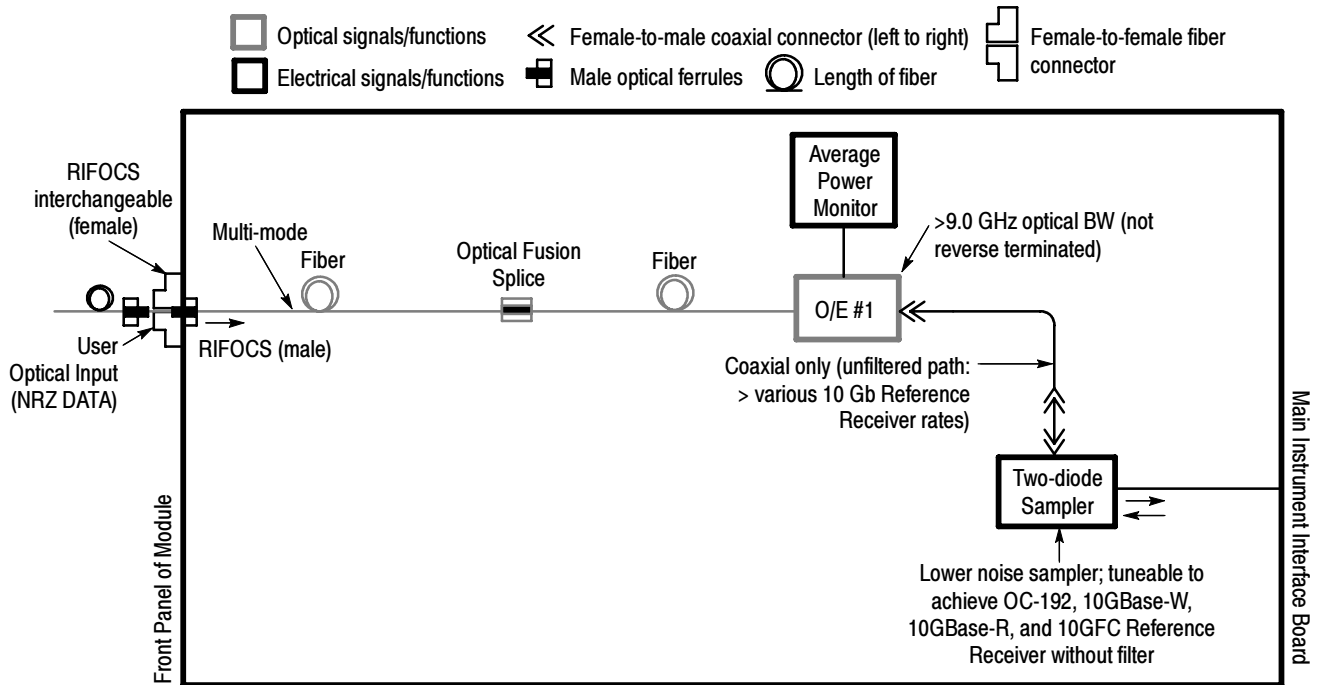

Figure 5- 15: 80C08/80C08B/80C08C Optical sampling block diagram

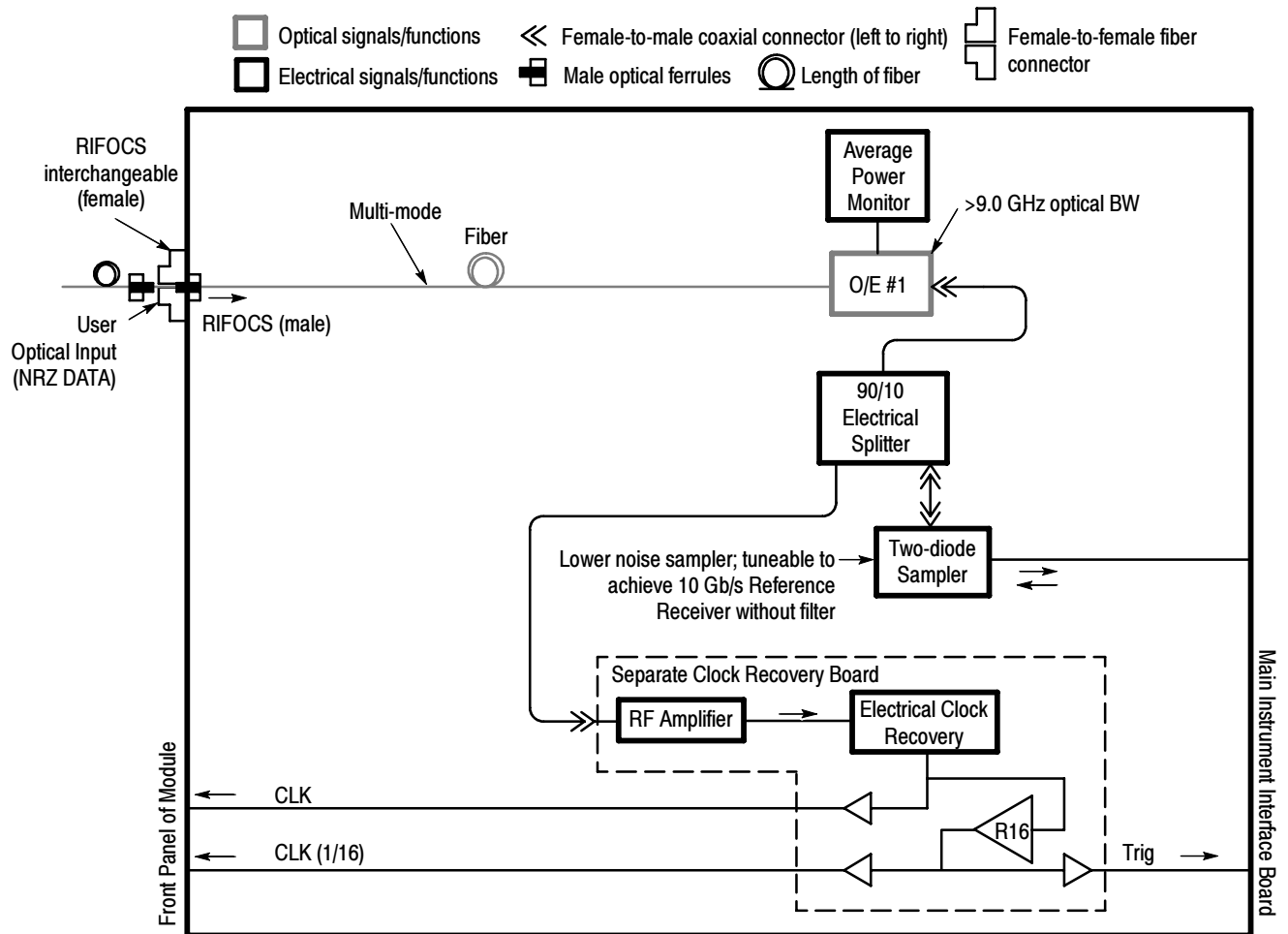

Figure 5- 16: 80C08/80C08B/80C08C Optical sampling with CR1, CR2, & CR4 clock recovery block diagram

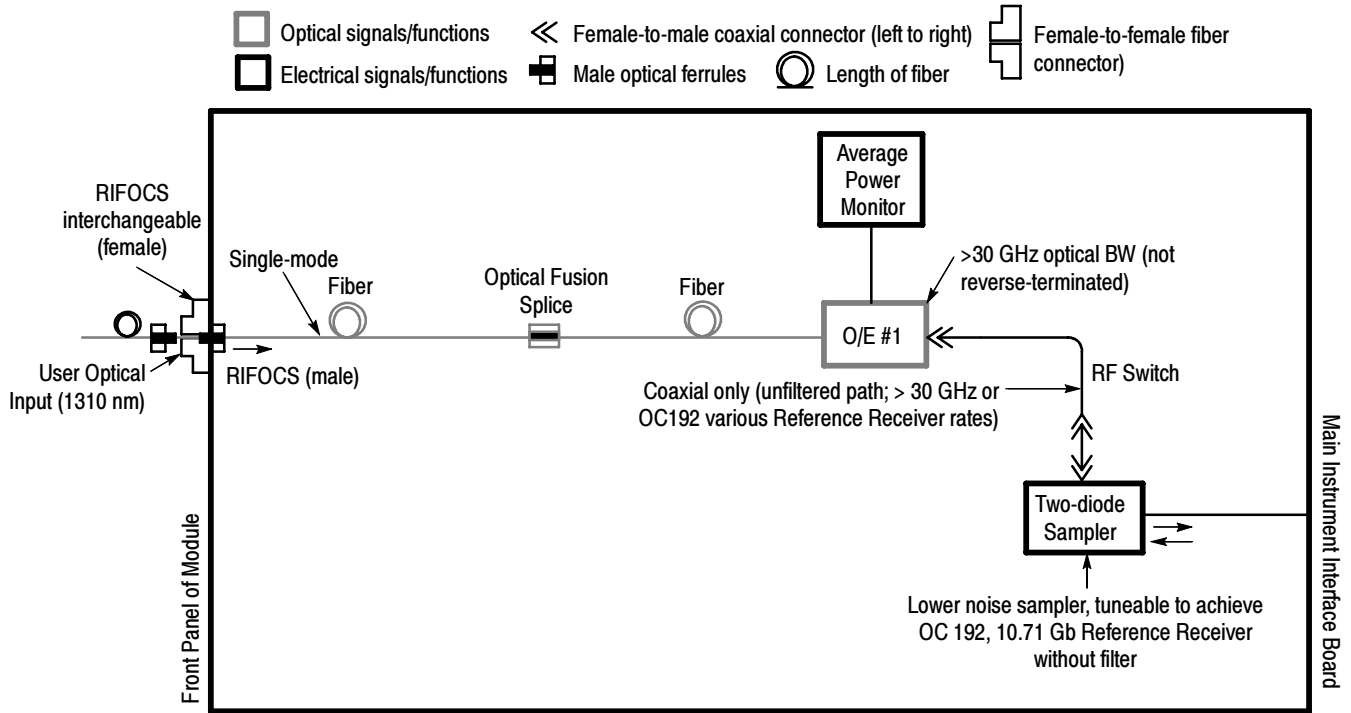

Figure 5- 17: 80C09 Optical sampling block diagram

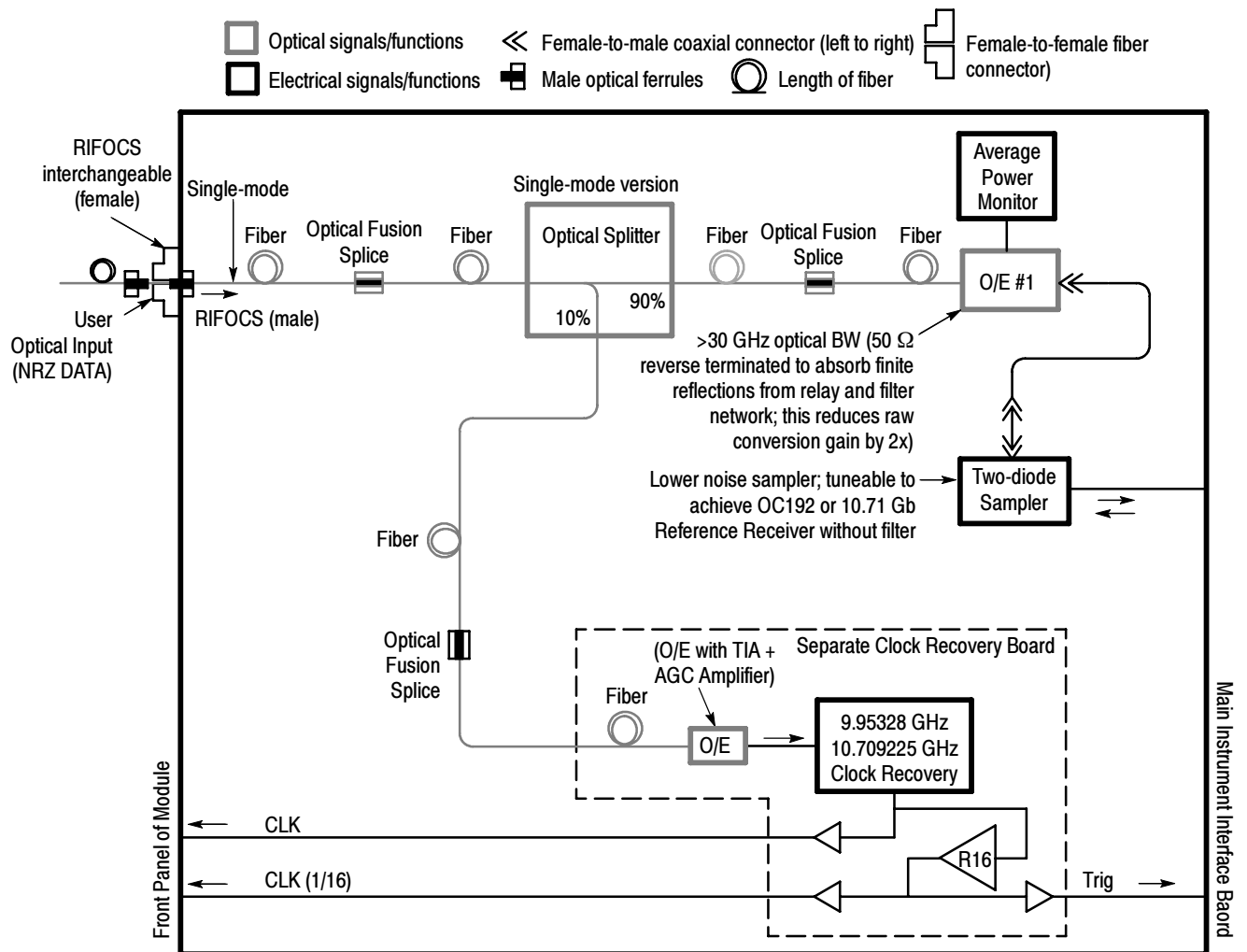

Figure 5- 18: 80C09 Optical sampling with CR1 clock recovery block diagram

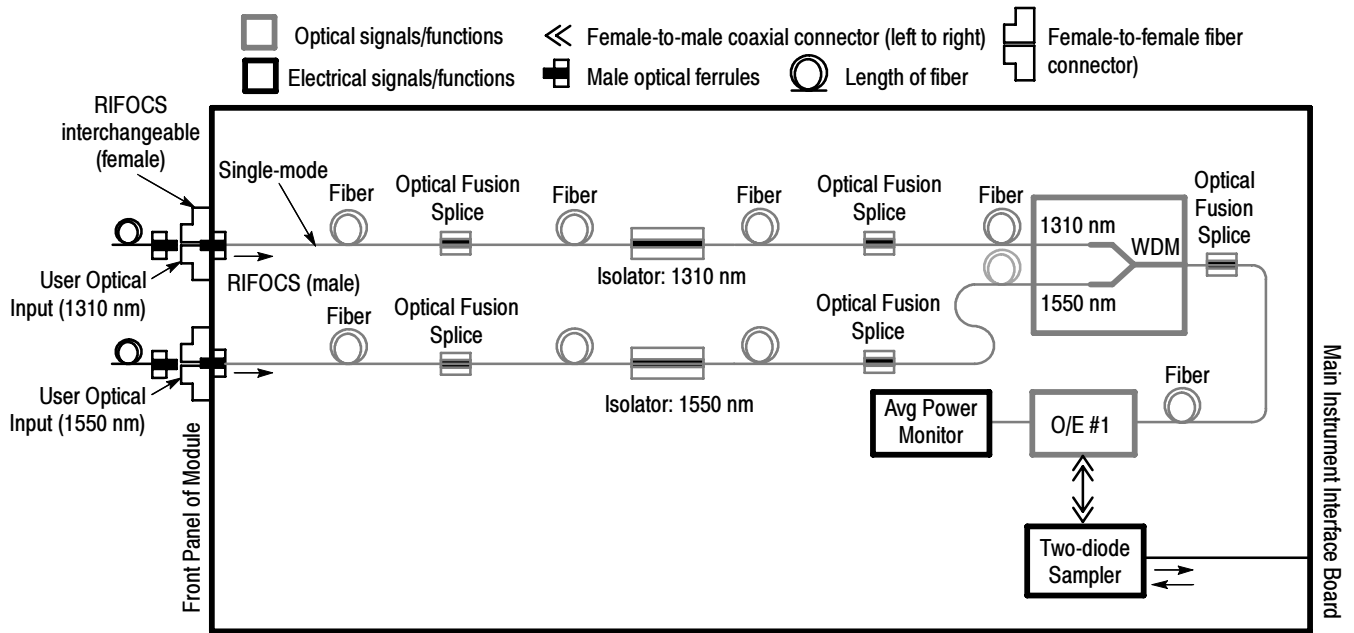

Figure 5- 19: 80C10 Optical sampling block diagram

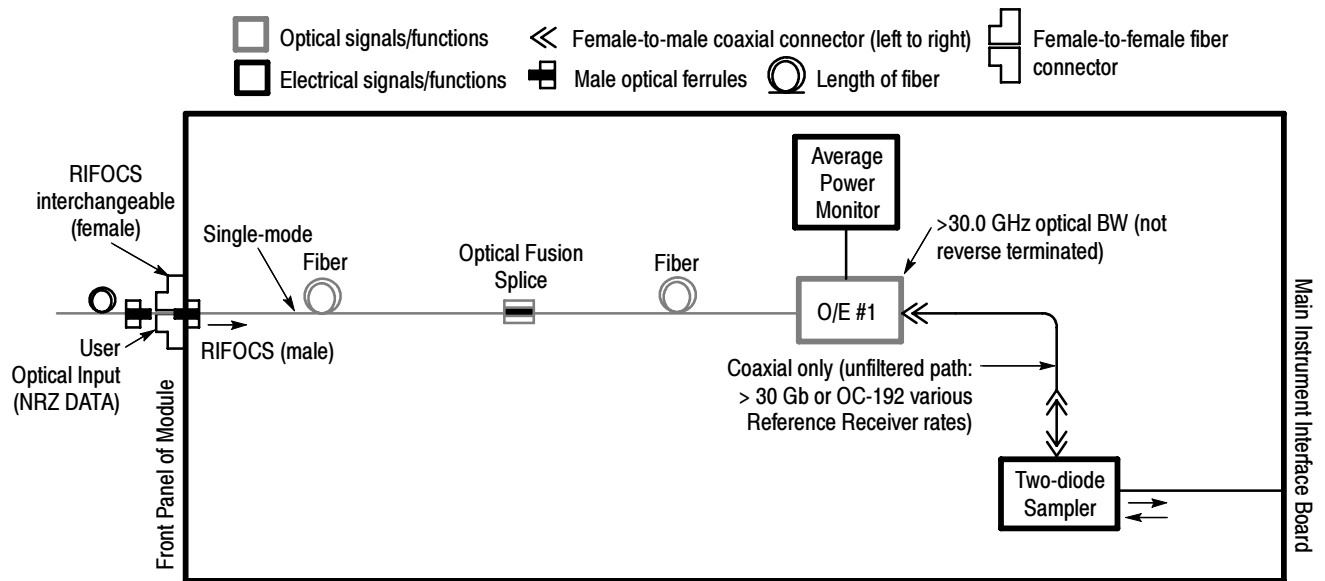

Figure 5-20: 80C11 Optical sampling block diagram

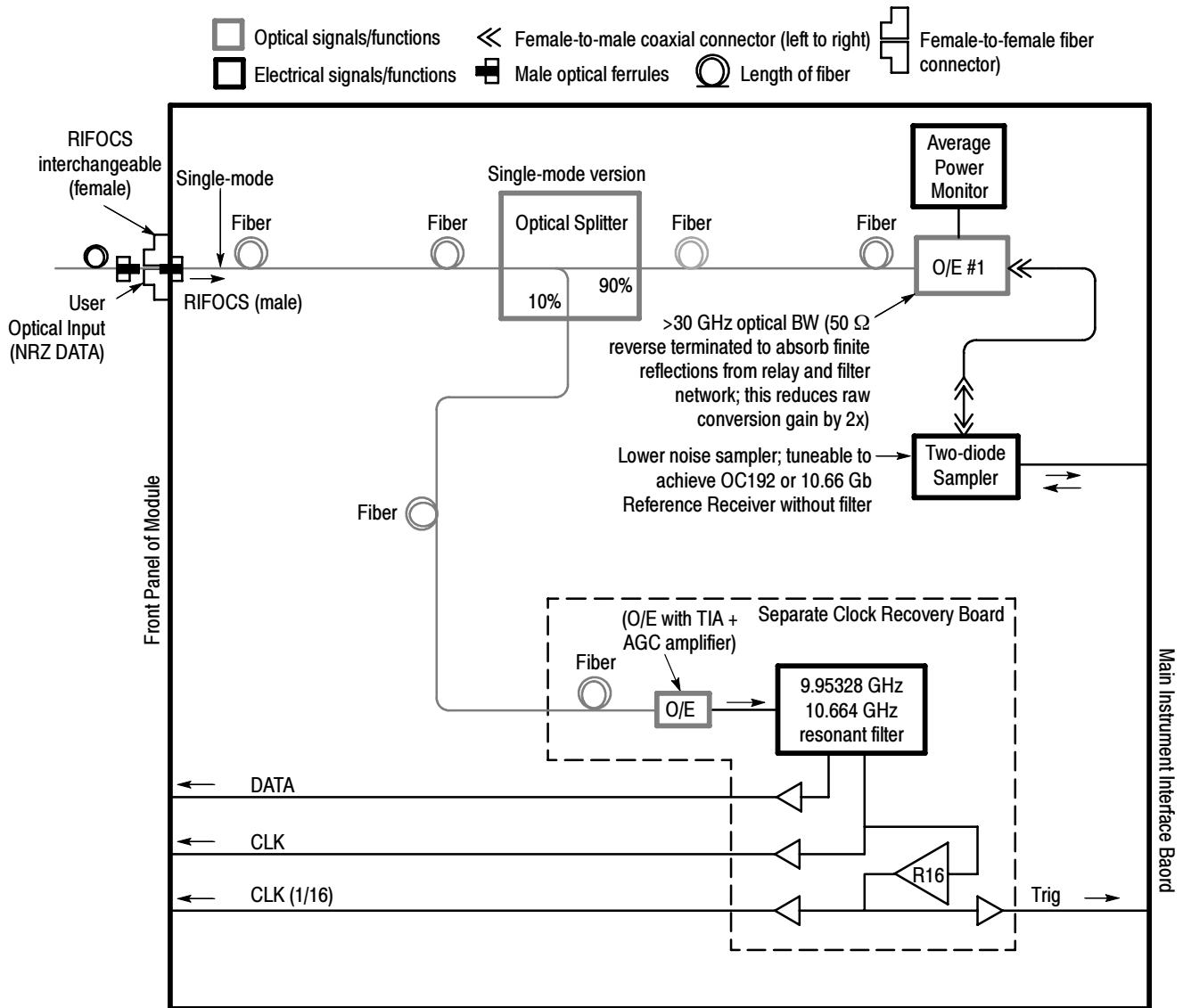

Figure 5-21: 80C11 Optical sampling with CR1 clock recovery option block diagram

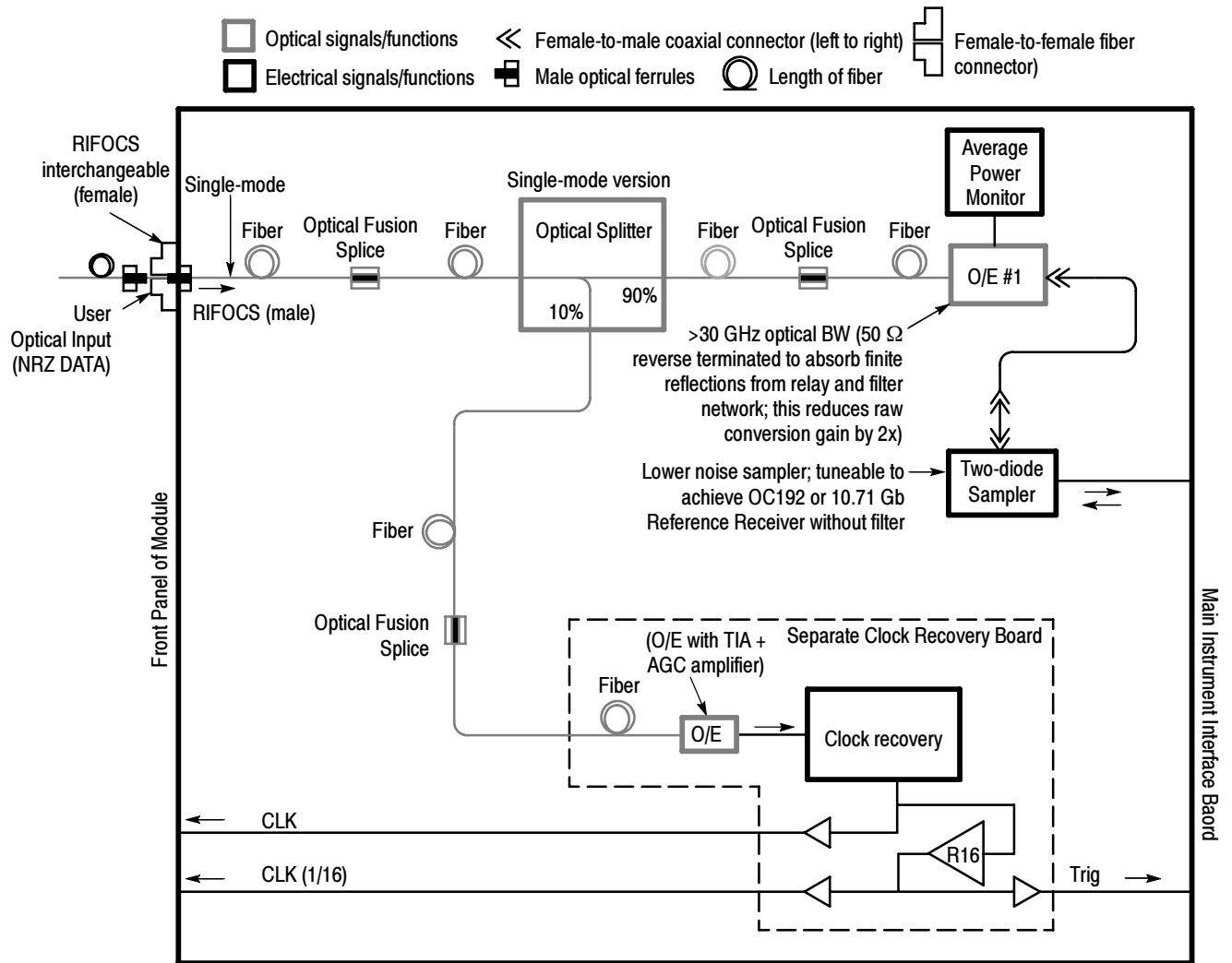

Figure 5-22: 80C11 Optical sampling with CR2 and CR3 clock recovery option block diagram

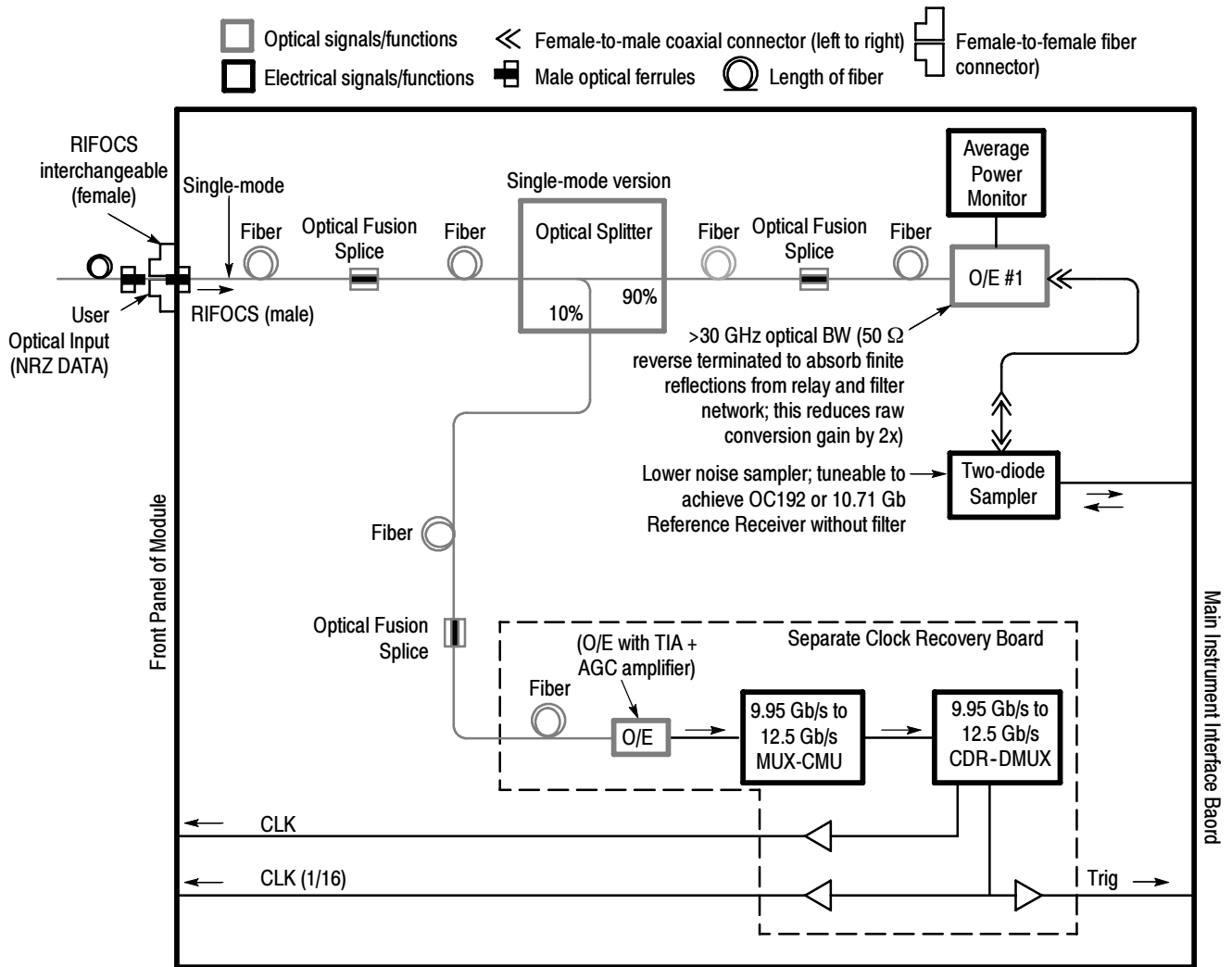

Figure 5-23: 80C11 Optical sampling with CR4 clock recovery option block diagram

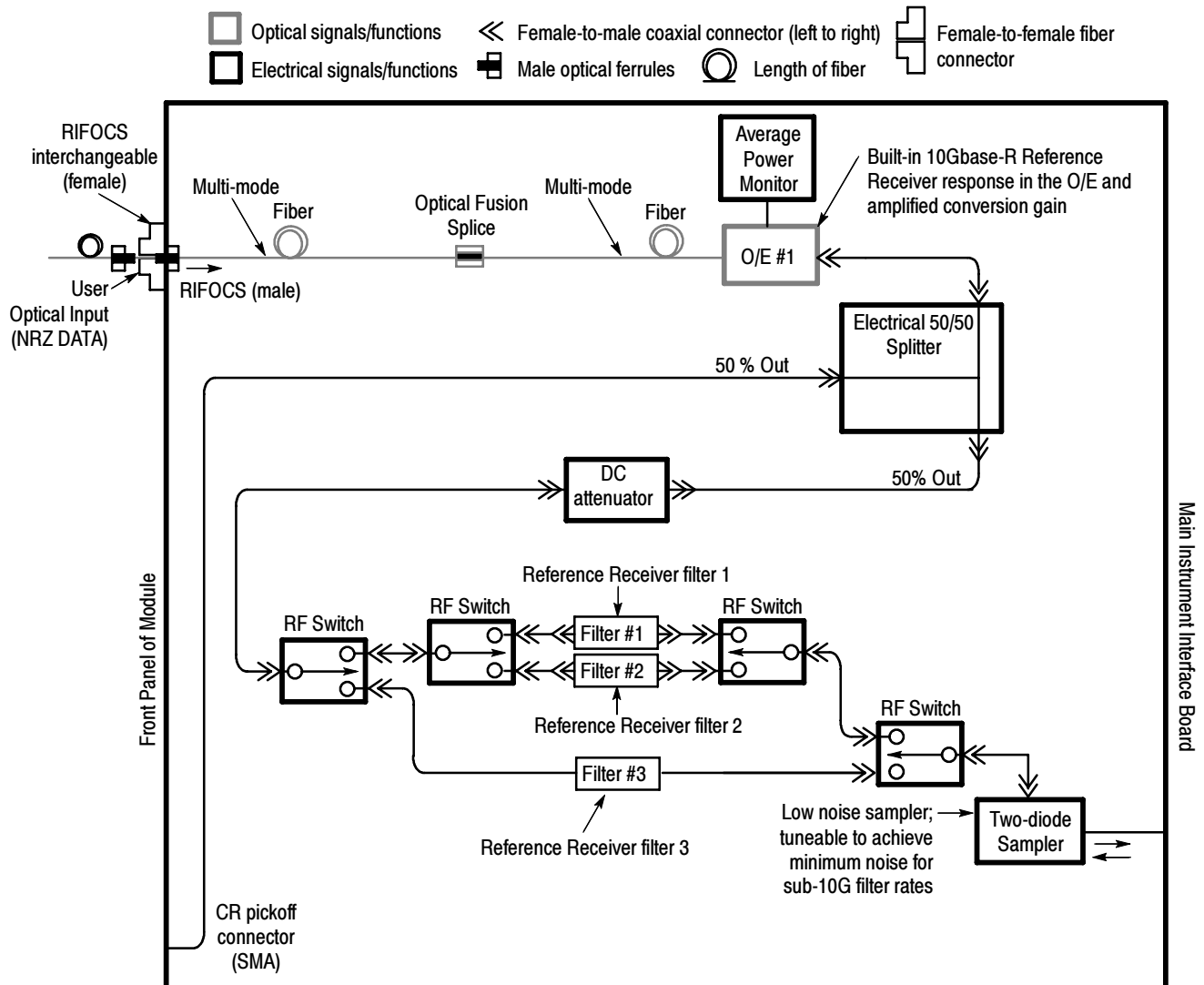

Figure 5-24: 80C12 Optical sampling block diagram

80A01 Block Diagram

Figure 5-25 show the interconnections between major circuit blocks of the 80A01 module.

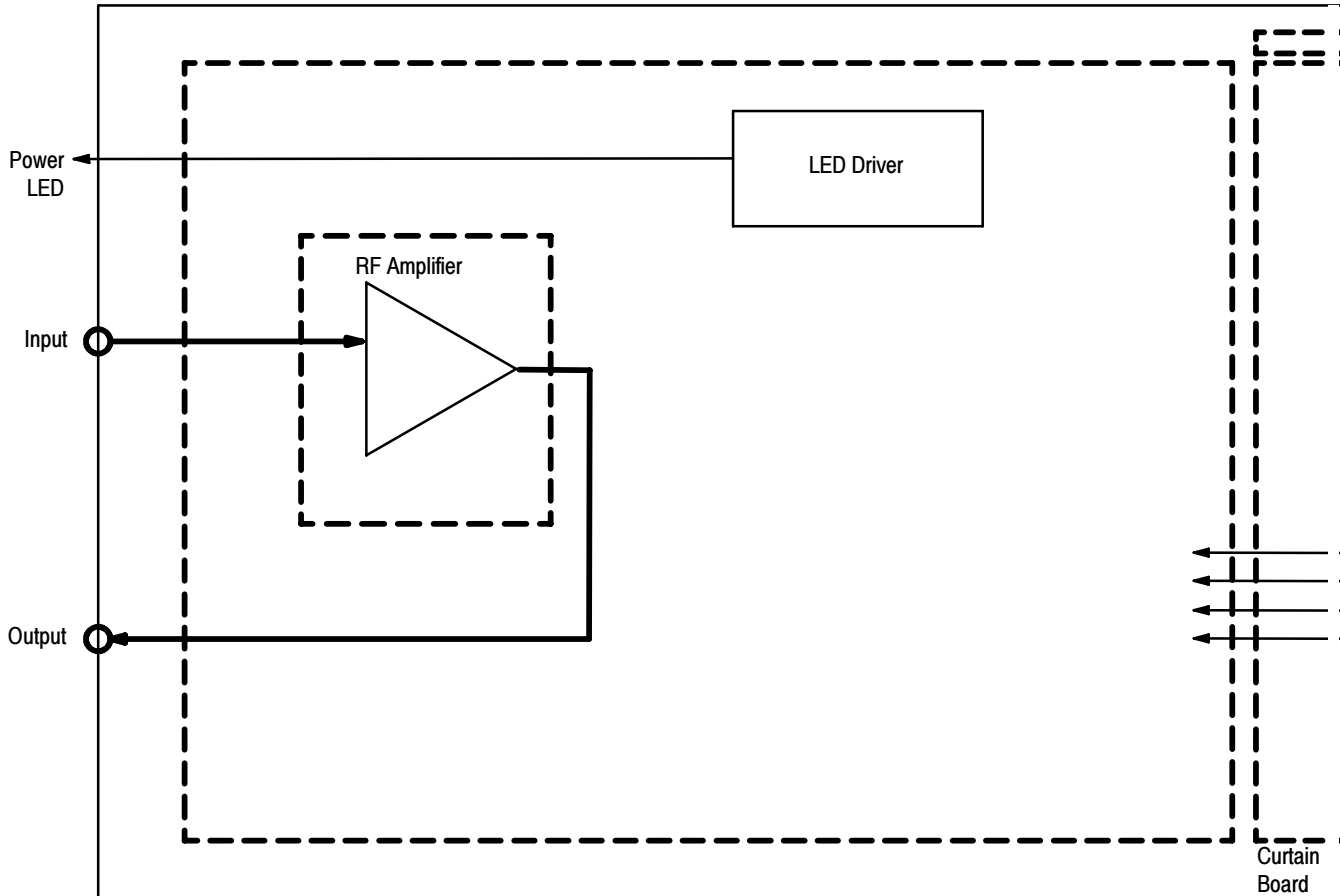

Figure 5-25: 80A01 block diagram

80A02 Block Diagram

Figure 5-26 shows the interconnections between major circuit blocks of the 80A02 module.

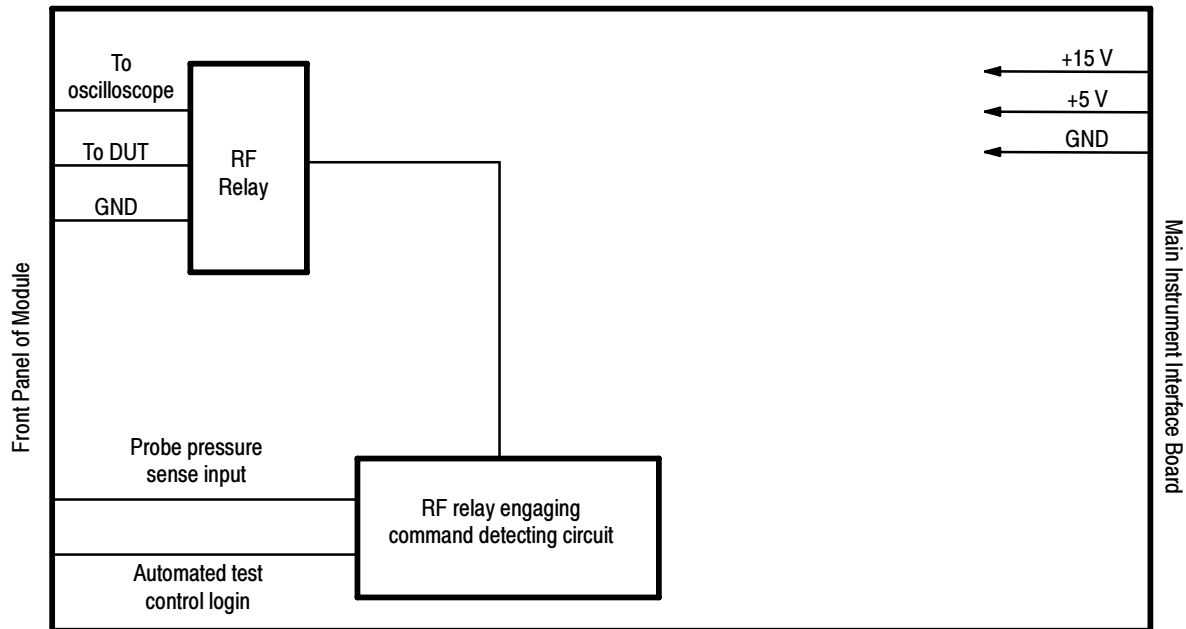

Figure 5-26: 80A02 block diagram

80A05 Block Diagram

Figure 5-27 shows the interconnections between major circuit blocks of the 80A05 module.

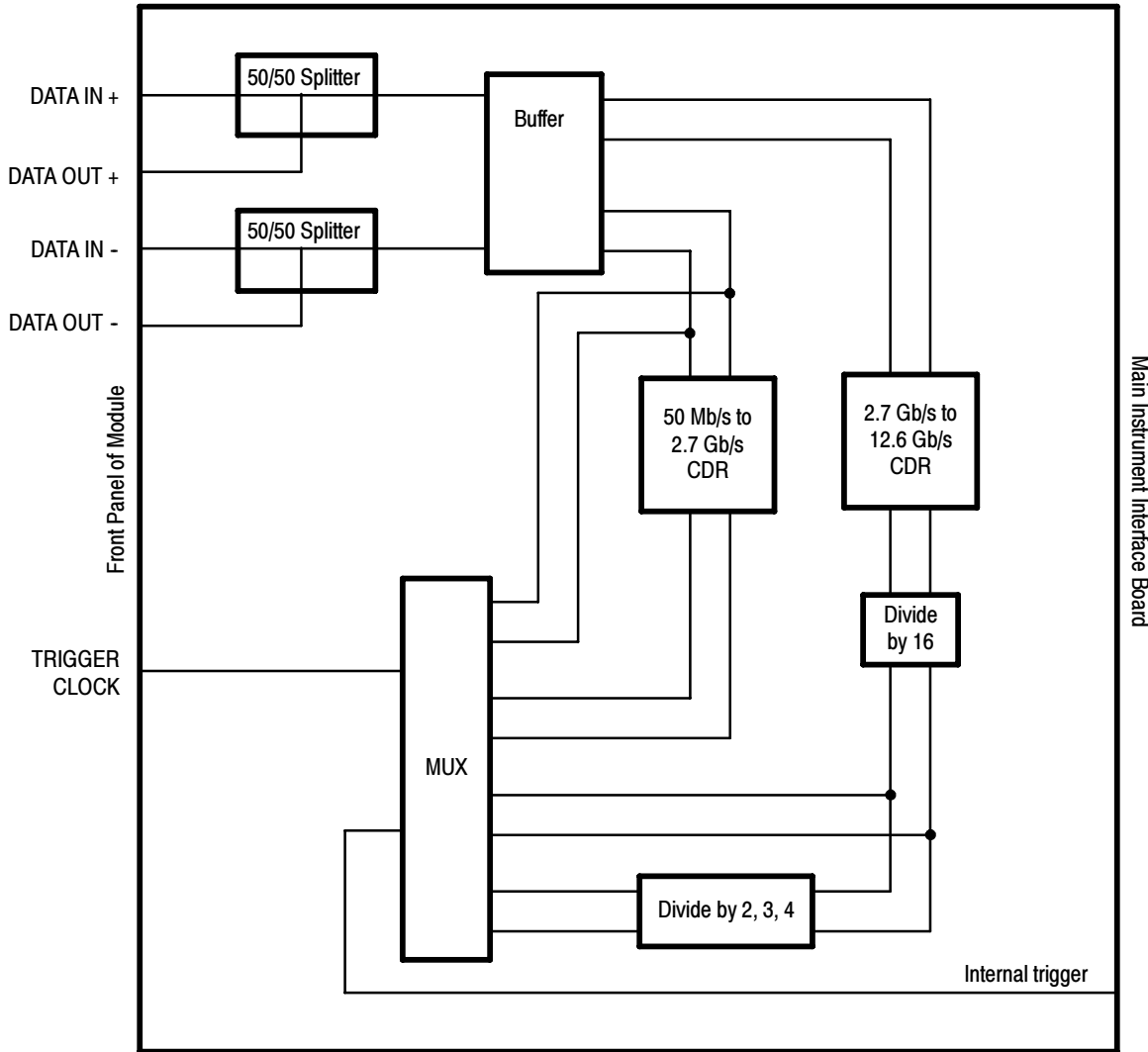

Figure 5-27: 80A05 block diagram

80A06 Block Diagram

Figure 5-28 shows the interconnections between major circuit blocks of the 80A06 module.

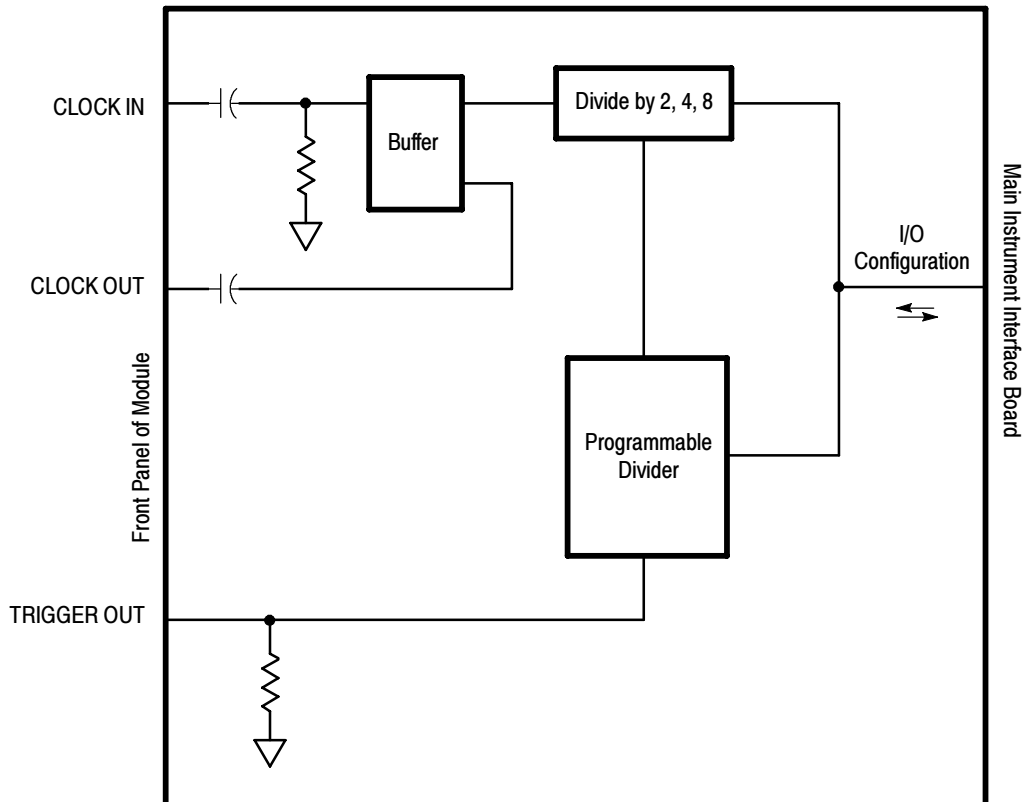

Figure 5-28: 80A06 block diagram

82A04 Block Diagram

Figure 5-29 shows the interconnections between major circuit blocks of the 82A04 module.

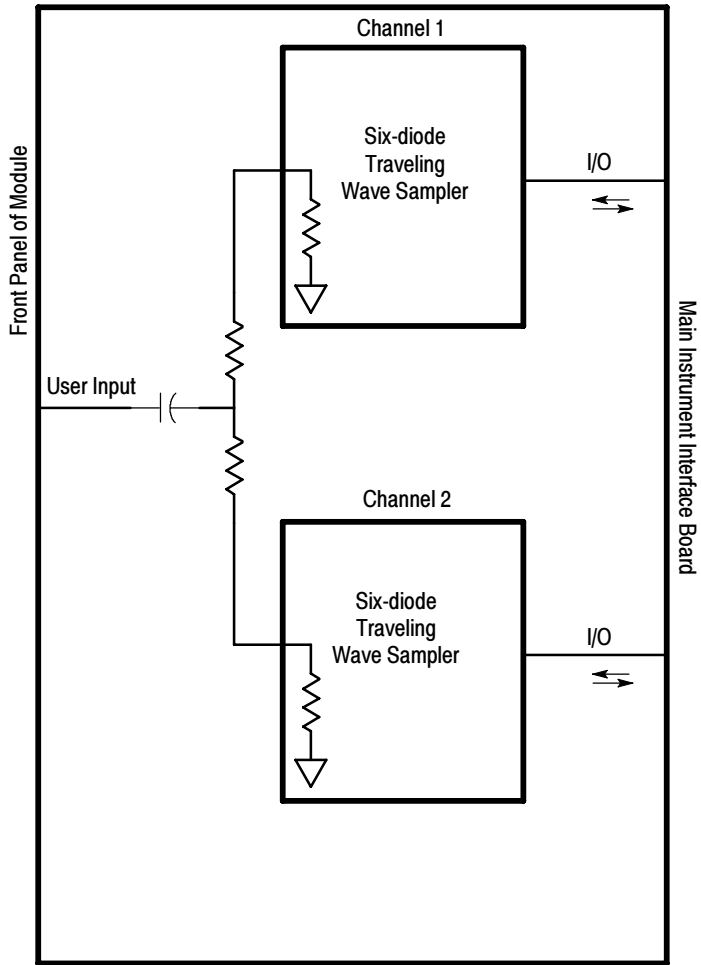

Figure 5-29: 82A04 block diagram



Replaceable Parts

Replaceable Parts List

This chapter contains a list of the replaceable modules for the instrument. Use this list to identify and order replacement parts.

Parts Ordering Information

Replacement parts are available through your local Tektronix field office or representative.

Changes to Tektronix instruments are sometimes made to accommodate improved components as they become available and to give you the benefit of the latest circuit improvements. Therefore, when ordering parts, it is important to include the following information in your order.

- Part number
- Instrument type or model number
- Instrument serial number
- Instrument modification number, if applicable

If you order a part that has been replaced with a different or improved part, your local Tektronix field office or representative will contact you concerning any change in part number.

Module Servicing

Modules can be serviced by selecting one of the following three options. Contact your local Tektronix service center or representative for repair assistance.

Module Exchange. In some cases you may exchange your module for a remanufactured module. These modules cost significantly less than new modules and meet the same factory specifications. For more information about the module exchange program, call 1-800-TEK-WIDE, extension 6630.

Module Repair and Return. You may ship your module to us for repair, after which we will return it to you.

New Modules. You may purchase replacement modules in the same way as other replacement parts.

Using the Replaceable Parts List

This section contains a list of the mechanical and/or electrical components that are replaceable for the instrument. Use this list to identify and order replacement parts. The following table describes each column in the parts list.

Parts list column descriptions

Column	Column name	Description
1	Figure & Index Number	Items in this section are referenced by component number.
2	Tektronix Part Number	Use this part number when ordering replacement parts from Tektronix.
3 and 4	Serial Number	Column three indicates the serial number at which the part was first effective. Column four indicates the serial number at which the part was discontinued. No entries indicates the part is good for all serial numbers.
5	Qty	This indicates the quantity of parts used.
6	Name & Description	An item name is separated from the description by a colon (:). Because of space limitations, an item name may sometimes appear as incomplete. Use the U.S. Federal Catalog handbook H6-1 for further item name identification.
7	Mfr. Code	This indicates the code of the actual manufacturer of the part. (Code to name and address cross reference is located after this page.)
8	Mfr. Part Number	This indicates the actual manufacturer's or vendor's part number.

Abbreviations Abbreviations conform to American National Standard ANSI Y1.1-1972.

Mfr. Code to Manufacturer Cross Index The following table cross indexes codes, names, and addresses of manufacturers or vendors of components listed in the parts list.

**Mfr. Code to Manufacturer
Cross Index**

The table titled Manufacturers Cross Index shows codes, names, and addresses of manufacturers or vendors of components listed in the parts list.

Manufacturers cross index

Mfr. code	Manufacturer	Address	City, state, zip code
00779	AMP INC.	CUSTOMER SERVICE DEPT PO BOX 3608	HARRISBURG, PA 17105-3608
01295	TEXAS INSTRUMENTS INC	SEMICONDUCTOR GROUP 13500 N CENTRAL EXPRESSWAY PO BOX 655303	DALLAS, TX 75272-5303
01963	CHERRY ELECTRICAL PRODUCTS CO	3600 SUNSET AVENUE	WAUKEGAN, IL 60087-3214
02660	AMPHENOL CORP	720 SHERMAN AVE	HAMDEN, CT 06514-6514
03ZT7	MOBILE PLANET	9175 DEERING AVE	CHATSWORTH, CA 91311
04713	MOTOROLA INC	SEMICONDUCTOR PRODUCTS SECTOR 5005 E MCDOWELL ROAD	PHOENIX, AZ 85008-4229
049S6	FUJITSU COMPUTER PRODUCTS OF AMERICA INC	2904 ORCHARD PARKWAY	SAN JOSE, CA 95134-2009
05791	LYN-TRON INC	SOUTH 6001 THOMAS MALLEEN RD	SPOKANE, WA 99204
060D9	UNITREK CORPORATION	3000 COLUMBIA HOUSE BLVD, SUITE 120	VANCOUVER, WA 98661
06666	GENERAL DEVICES	PO BOX 39100	INDIANAPOLIS, IN 46239
06915	RICHCO	5825 N TRIPP AVE P.O. BOX 804238	CHICAGO, IL 60646
07416	NELSON NAME PLATE COMPANY	3191 CASITAS AVENUE	LOS ANGELES, CA 90039-2410
0ADN8	DELTA PRODUCTS CORP-DPZ	4405 CUSHING PARKWAY	FREMONT, CA 94538
0GZV8	HUBER & SUHNER INC	19 THOMPSON DRIVE	ESSEX JUNCTION, VT 05452-3408
0J9P9	GEROME MFG CO INC	PO BOX 737 403 NORTH MAIN	NEWBERG, OR 97132
0KB01	STAUFFER SUPPLY CO	810 SE SHERMAN	PORTLAND, OR 97214-4657
0KB05	NORTH STAR NAMEPLATE INC	5750 NE MOORE COURT	HILLSBORO, OR 97124-6474
0KBZ5	Q & D PLASTICS INC	1812 - 16TH AVENUE PO BOX 487	FOREST GROVE, OR 97116-0487
12136	PHC INDUSTRIES INC	1643 HADDON AVE PO BOX 1448	CAMDEN, NJ 08103
16179	M/A COM INC	1011 PAWTUCKER BLVD. PO BOX 3295	LOWELL, MA 01853-3295
1AW87	LEWIS SCREW CO.	4300 SOUTH RACINE AVENUE	CHICAGO, IL 60609
1DM20	PARLEX CORP	7 INDUSTRIAL WAY	SALEM, NH 03079
20944	ANRITSU COMPANY	685 JARVIS DRIVE	MORGAN HILLS, CA 95037
22526	FCI/BERG ELECTRONICS INC	825 OLD TRAIL ROAD	ETTERS, PA 17319-9769
22670	GM NAMEPLATE INCORPORATED	2040 15TH AVE WEST	SEATTLE, WA 98119-2783
24931	FCI/BERG ELECTRONICS INC	RF/COAXIAL DIV 2100 EARLYWOOD DR PO BOX 547	FRANKLIN, IN 46131
26003	MARTEK POWER MDI	4115 SPENCER STREET	TORRANCE, CA 90503-2489

Replaceable Parts List

Manufacturers cross index (cont.)

Mfr. code	Manufacturer	Address	City, state, zip code
26805	M/A COM OMNI SPECTRA INC	MICROWAVE CONNECTOR DIV 140 4TH AVE	WALTHAM, MA 02254
2K262	BOYD CORPORATION	6136 NE 87TH AVENUE	PORTLAND, OR 97220
2W733	BELDEN WIRE & CABLE COMPANY	2200 US HWY 27 SOUTH PO BOX 1980	RICHMOND, IN 47374
304371	PFU SYSTEMS INC	1331 LAWRENCE EXPY #200	SANTA CLARA, CA 95051
32559	BIVAR INC	4 THOMAS ST	IRVINE, CA 92718
34649	INTEL CORPORATION	3065 BOWERS PO BOX 58130	SANTA CLARA, CA 95051-8130
3M099	PORTLAND SCREW COMPANY	6520 N BASIN AVE	PORTLAND, OR 97217
46628	LOGITECH INC	6505 KAISER DR	FREMONT, CA 94555
50356	TEAC AMERICA INC	7733 TELEGRAPH RD PO BOX 750	MONTEBELLO, CA 90640-6537
5Y400	TRIAx METAL PRODUCTS INC	1880 SW MERLO DRIVE	BEAVERTON, OR 97006
64537	KDI/TRIANGLE CORPORATION	60 S JEFFERSON RD	WHIPPANY, NJ 07981
6Y440	MICRON SEMICONDUCTOR PRODUCTS INC	8000 S FEDERAL WAY PO BOX 6	BOISE, ID 83707-0006
61058	MATSUSHITA ELECTRIC CORP OF AMERICA	PANASONIC INDUSTRIAL CO DIV TWO PANASONIC WAY	SECAUCUS, NJ 07094
61162	JFW INDUSTRIES INC	5134 COMMERCE SQUARE DRIVE	INDIANAPOLIS, IN 46237-9738
64537	KDI/TRIANGLE CORPORATION	60 S JEFFERSON RD	WHIPPANY, NJ 07981
71400	BUSSMANN	DIVISION COOPER INDUSTRIES INC PO BOX 14460	ST LOUIS, MO 63178
74594	COMPONENT RESOURCES INC	BUSSMAN PARTS C/O CASEY LAKEY 14525 SW WALKER ROAD	BEAVERTON, OR 97006
76096	ELMA ELECTRONICS INC	41440 CHRISTY ST	FREMONT, CA 94538
78189	SHAKEPROOF	DIVISION OF ILLINOIS TOOL WORK ST. CHARLES ROAD	ELGIN, IL 60120
7X318	KASO PLASTICS INC	5720-C NE 121ST AVE, STE 110	VANCOUVER, WA 98682
80009	TEKTRONIX INC	14150 SW KARL BRAUN DR PO BOX 500	BEAVERTON, OR 97077-0001
86928	SEASTROM MFG CO INC	456 SEASTROM STREET	TWIN FALLS, ID 83301
8X345	NORTHWEST SPRING MFG CO	5858 WILLOW LANE	LAKE OSWEGO, OR 97035
93907	CAMCAR DIV OF TEXTRON INC	ATTN: ALICIA SANFORD 516 18TH AVE	ROCKFORD, IL 611045181
94222	SOUTHCO, INC.	210 N BRINTON LAKE RD	CONCORDVILLE, PA 19331
98291	ITT CANNON RF PRODUCTS	585 EAST MAIN STREET	NEW BRITAIN, CT 06051
S4091	SANYO DENKI	C/O TJBO LIAISON M/S 78-210	BEAVERTON, OR 97077-7077
S5769	NEC CORPORATION	NEC BUILDING 7-1, SHIBA 5 CHOME MINATO-KU	TOKYO, JP 108
TK0588	UNIVERSAL PRECISION PRODUCT	1775 NW CORNELIUS PASS RD	HILLSBORO, OR 97124

Manufacturers cross index (cont.)

Mfr. code	Manufacturer	Address	City, state, zip code
TK1163	POLYCAST INC	14140 SW 72ND AVE SUITE 100	TIGARD, OR 97224
TK1916	SKS DIE CASTING & MACHINING INC.	1849 OAK ST	ALAMEDA, CA 94501
TK1943	NEILSEN MANUFACTURING INC	3501 PORTLAND RD NE	SALEM, OR 97303
TK2172	WYLE ELECTRONICS INC	10300 SW NIMBUS AVE BLDG P, SUITE B	PORTLAND, OR 97223
TK2250	ARROW ELECTRONICS INC.	9500 SW NIMBUS AVE, BLDG E	BEAVERTON, OR 97008-7163
TK2338	ACC MATERIALS	ED SNYDER BLDG 38-302	BEAVERTON, OR 97077
TK2376	CONDUCTIVE RUBBER TECH	22125 17TH AVE SE, SUITE 117	BOTHELL, WA 98021
TK2491	RIFOCS CORPORATION	1340 FLYNN RD	CAMARILLO, CA 93012
TK2539	ROYAL CASE COMPANY INC	315 S MONTGOMERY PO BOX 2231	SHERMAN, TX 75070
TK2548	XEROX CORPORATION	14181 SW MILLIKAN WAY	BEAVERTON, OR 97005
TK2563	REVTEK INC	4288 SE INTERNATIONAL WAY	PORTLAND, OR 97222
TK2565	VISION PLASTICS INC	26000 SW PARKWAY DRIVE	WILSONVILLE, OR 97070
TK2582	TUFF CAT USA LLC	814 N HAYDEN MEADOWS DRIVE	PORTLAND, OR 97217
TK2601	MAXTEK COMPONENTS CORPORATION	13335 SW TERMAN RD PO BOX 428	BEAVERTON, OR 97075-0428
TK2647	INSTRUMENT SPECIALTIES CO INC.	C/O TEMCO NW 1336 SE 51ST STREET	HILLSBORO, OR 97123
TK6121	TUMBLER CORP	175 KOOTENAI DR	FREMONT, CA 94539
TK6173	MULTI-FINELINE ELECTRONIX INC (MFLEX)	DBA: MFLEX 1301 N DYNAMICS STREET	ANAHEIM, CA 92806
TK6181	IMC PLASTICS INC	19400 SW TETON AVE	TUALATIN, OR 97062
TK6253	VOLEX INTERCONNECT INC	646 CARRIBEAN DR	SUNNYVALE, CA 94089-1108

Replaceable Parts List

Replaceable Parts List

Fig. & index number	Tektronix part number	Serial no. effective	Serial no. discont'd	Qty	Name & description	Mfr. code	Mfr. part number
1-1	016-1441-00			1	POUCH, PLASTIC: PLASTIC POUCH	80009	016-1441-00
-2	211-1050-00			12	SCREW,MACHINE:6-32 X 0.312 L,PNH,STL CAD,T15	0KB01	OBD
-3	355-0298-00			4	STUD.SNAP:0.570 DIA,0.165 THK,STAINLESS STEEL	TK0588	355-0298-00
-4	348-1648-00			4	FOOT:REAR W/CORD WRAP,THERMOPLASTIC	TK6181	348-1648-00
-5	211-0720-00			4	SCR,ASSEM WSHR:6-32 X 0.500,PNH,STL,CDPL,T-15	0KB01	OBD
-6	161-0230-01			1	CABLE ASSY,PWR,:3,18 AWG,92 L,SVT, (STANDARD ACCESSORY)	TK2432	ORDER BY DESC
-7	159-0046-00			2	FUSE,CARTRIDGE:3AG,8A,250V,15SEC,CER	71400	ABC 8
	159-0381-00			2	FUSE,CARTRIDGE:5 X 20 MM,6.3A,250V,FAST BLOW,HIGH BREAKING CAPACITY,UL REC,SEMKO,	71400	GDA-6.3
-8	200-2264-00			2	CAP,FUSEHOLDER:3AG FUSES (AMERICAN)	61935	FEK 031 1666
	200-2265-00			2	CAP,FUSEHOLDER:5 X 20MM FUSES (EUROPEAN)	61935	FEK 031.1663
-9	200-4522-00			1	COVER,RIGHT:PCABS,13.645L X 8.250W, BLUE	TK6181	200-4522-00
-10	212-0232-00			2	SCREW,MACHINE:8-32 X 1.125L, PNH,STL,BLACK OXIDE,T-20	0KB01	OBD
-11	367-0528-00			1	HANDLE,CARRYING:POLYPROPYLENE VINYL GRIP SECTION	12136	PT 3170
-12	200-4556-00			1	COVER, BOTTOM RIGHT:0.050 ALUMINUM	0J9P9	200-4556-00
-13	200-4625-00			1	COVER,BOTTOM:0.060 AL,VINYL CLAD, INCLUDING FEET (ITEMS 13 & 14)	0J9P9	200-4625-00
-14	348-1515-00			1	FEET,CABINET:CABINET FEET,BLACK,GLASS-FIBRE REINFORCED PLASTIC,SET OF 4 FEET (FRONT AND REAR), W/SCREWS	76096	63-526
-15	101-0150-00			1	TRIM:ACQUISITION, PCABS (CSA8000, TDS8000, CSA8000B, TDS8000B)	TK6181	101-0150-00
	101-0167-00			1	TRIM:ACQUISITION, PCABS (CSA8200, TDS8200)	TK6181	101-0167-00
-16	200-4519-00			1	COVER,FRONT:PCABS,17.420L X 8.670W X 2.000	TK6181	200-4519-00
-17	101-0151-01			1	TRIM,FRONT:PCABS,17.200W X 8.450H, SILVER GRAY	TK6181	101-0151-01
-18	260-2719-00			1	SWITCH,KEYPAD:ELASTOMERIC,FRONT PANEL,ON/OFF	TK2376	260-2719-00
-19	335-0660-00			1	MARKER,IDENT:LABEL,MAIN FRAME,0.500 X 8.510,LEXAN,W/ADHESIVE,CSA8000,	0KB05	335-0660-00
-19	335-0659-00			1	MARKER,IDENT:0.500 X 8.510,LEXAN W/ADHESIVE,MAIN FRAME,TDS8000,	0KB05	335-0656-00
-20	200-4555-00			1	COVER, TOP LEFT:0.050 ALUMINUM	0J9P9	200-4555-00
-21	200-4521-00			1	COVER,LEFT:PCABS,13.654L X 8.250W,BLUE	TK6181	200-4521-00
-22	200-4520-00			1	COVER, TOP:PCABS,17.200L X 13.550W,BLUE	TK6181	200-4520-00
-23	407-4887-00			1	BRACKET; HANDLE BASE,PC/ABS ALLOY,BAYER BAYBLEND FR-110,TEK BLUE,SAFETY CONTROLLED	TK2565	407-4887-00

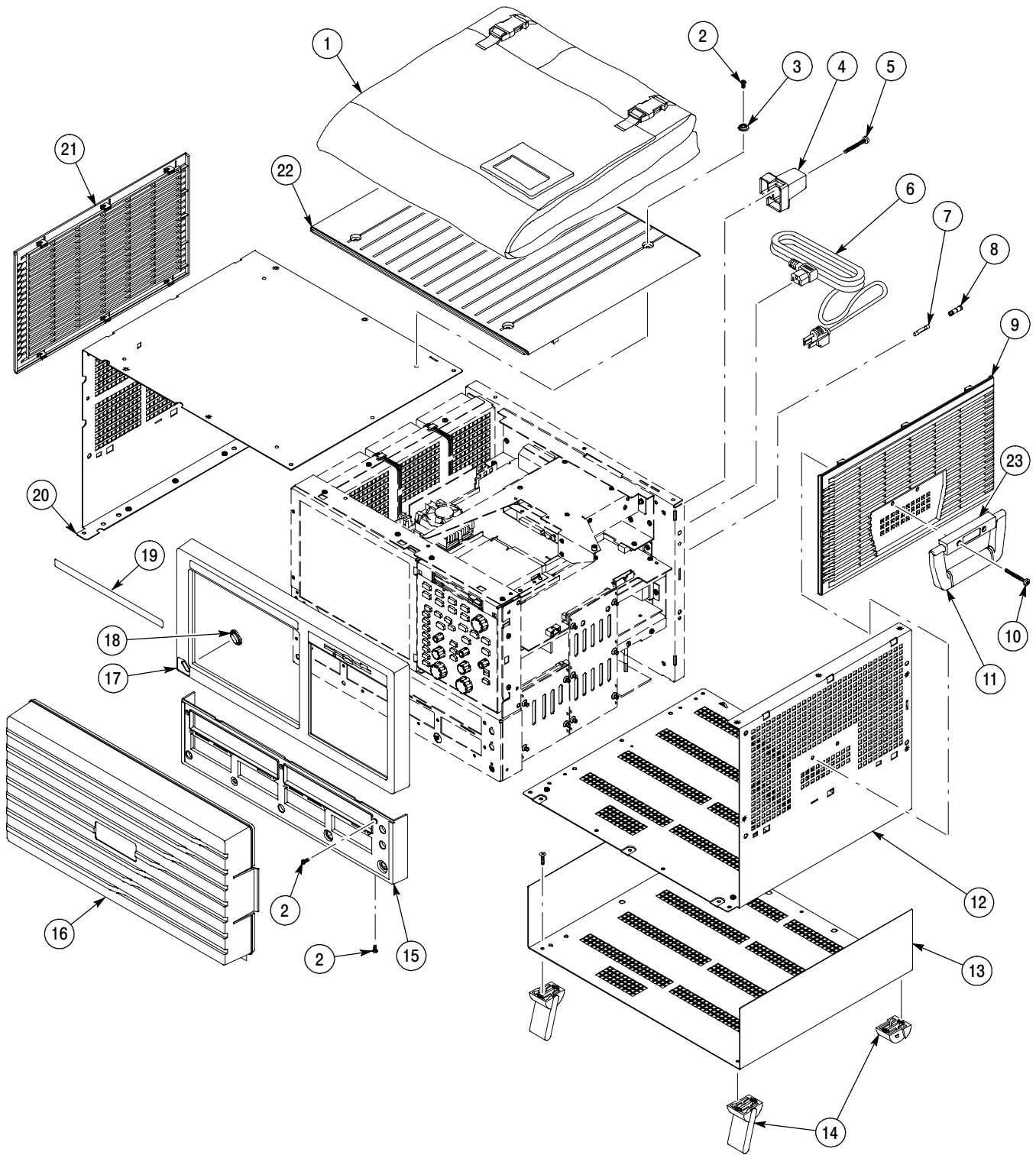

Figure 6-1: External parts

Replaceable Parts List

Replaceable Parts List

Fig. & index number	Tektronix part number	Serial no. effective	Serial no. discont'd	Qty	Name & description	Mfr. code	Mfr. part number
2-1	211-1050-00			8	SCREW,MACHINE:6-32 X 0.312 L,PNH,STL CAD,T15	0KB01	OBD
-2	650-4271-01			1	RHDD ASSEMBLY:W/O SW (ITEMS 3 THROUGH 7)	80009	650-4412-00
-3	119-6733-00			1	DISK DRIVE:WINCHESTER,2.5 IN, 20.0GB,SINGLE PLATTER	049S6	MHK2060AT
-4	437-0494-00			1	CABINET ASSY:REMOVEABLE HARD DISK DRIVE HOLDER	TK1943	437-0494-00
-5	211-1081-00			4	SCREW,MACHINE:M3 X 0.5 X 3.5MM	0KB01	211-1081-00
-6	174-3925-00			1	CA ASSY,SP:RIBBON,,28 AWG,1.0 L,2 X 22 (HARD DRIVE)	060D9	174-3925-00
-7	679-4378-00			1	CKT BD SUBASSY:HARD DISK DRIVE INTERFACE	80009	679-4378-00
-8	174-4320-00			2	CA ASSY:FLAT FLEX, 9.753L (FLOPPY DRIVE CABLE & FRONT PANEL)	060D9	174-4320-00
-9	671-4657-01			1	CIRCUIT BD ASSY:PROCESSOR (CSA8000, TDS8000, CSA8000B, TDS8000B)	80009	671-4657-01
	644-1045-01			1	NLX BOARD ASSY; RADISYS,SF810-L-C850 PCI/ISA MOTHER BOARD,W/ INTEL 850MHZ CELERON PROCESSOR,W/O MEMORY (CSA8200, TDS8200)	80009	644-1045-01
-10	407-4706-00			1	BRACKET:FLOPPY DRIVE,6.064 X 5.075,ALUMINUM	TK1943	407-4706-00
-11	211-1079-00			2	SCREW,MACHINE:2.6 X 0.45 MM,3.0L,PNH,STL,PHILLIPS	0KB01	10310188-0
-12	119-6106-00			1	DISK DRIVE:FLOPPY,3.5INCH,1.44 MB, 0.5 IN,DDDS	TK2250	FD-05HF5630
-13	174-4241-01			1	CA,ASSY:RIBBON,BUS,IDC,32 AWG,17.00L,60POS (PROCESSOR TO ACQ)	060D9	174-4241-01
-14	361-1762-00			1	SPACER,SUPPORT:0.250 X 0.171 X 0.375,CKT BD,NYLON	06915	CPST-4-01
-15	679-4761-00			1	CKT BD SUBASSY:POWER REAR	80009	679-4761-00
-16	679-4760-00			1	CKT BD SUBASSY:POWER FRONT	80009	679-4760-00
-17	614-0968-00			1	PANEL MODULE:FRONT,W/HARDWARE (ITEMS 18 THROUGH 23)	80009	614-0968-00
-18	679-4689-00			1	CKT BD SUBASSY:FRONT PANEL CONTROL BD	80009	679-4689-00
-19	260-2724-00			1	SWITCH,KEYPAD:ELASTOMERIC,FRONT PANEL	TK2376	260-2724-00
-20	366-0770-00			3	KNOB,CAP:0.925 DIA	TK1163	366077000
-21	366-0771-00			2	KNOB,CAP:SILVER GRAY,0.650 DIA X 0.520 H	TK1163	366-0771-00
-22	366-0772-00			3	KNOB,CAP:SIVER GRAY,0.425 DIA X 0.520 H	TK1163	366-0772-00
-23	333-4339-00			1	SUBPANEL,FRONT:6.380 X 7.700,ALUMINUM,LEXAN LABEL	TK1943	333-4339-00
-24	650-3938-00			1	COMPONENT KIT:DISPLAY MODULE (ITEMS 25 THROUGH 30)	80009	650-3938-00
-25	259-0155-01			1	FLEX CIRCUIT:POWER FLEX CIRCUIT SILVER INK	07416	259-0155-01
-26	650-4186-00			1	MODULE ASSY:TOUCH PANEL (ITEMS 25 & 26)	80009	650-4186-00
-27	174-4189-00			1	CABLE ASSEMBLY:FLAT FLEX (DISPLAY ADAPTER)	1DM20	174-4189-00
-28	650-4187-01			1	MODULE ASSY:LCD, DISPLAY (ITEMS 27 THROUGH 30)	80009	650-4187-01

Replaceable Parts List (cont.)

Fig. & index number	Tektronix part number	Serial no. effective	Serial no. discont'd	Qty	Name & description	Mfr. code	Mfr. part number
-29	679-4479-01			1	CKT BD SUBASSY:DISPLAY ADAPTER, W/HARDWARE (CSA8000 AND TDS8000)	80009	679-4479-01
	679-4479-01	B010100	B020346	1	CKT BD SUBASSY:DISPLAY ADAPTER, W/HARDWARE (CSA8000B)	80009	679-4479-01
	679-5244-00	B020347		1	CKT BD SUBASSY:DISPLAY ADAPTER, W/HARDWARE (CSA8000B)	80009	679-5244-00
	679-4479-01	B010100	B020362	1	CKT BD SUBASSY:DISPLAY ADAPTER, W/HARDWARE (TDS8000B)	80009	679-4479-01
	679-5244-00	B020363		1	CKT BD SUBASSY:DISPLAY ADAPTER, W/HARDWARE (TDS8000B)	80009	679-5244-00
	679-5244-00			1	CKT BD SUBASSY:DISPLAY ADAPTER, W/HARDWARE (CSA8200 AND TDS8200)	80009	679-5244-00
-30	174-3618-00			1	CA,ASSY SP:RIBBON,CPR,28 AWG,9.5 L,1X5,0.049CTR	060D9	OBD
-31	343-1676-00			1	CABLE CLAMP,PC/ABS,BAYER,BAYBLEND FR-110,SILVER GREY	TK2565	343-1676-00
-32	437-0486-01			1	ASSY,FAN:SIX FANS ASSEMBLY	0J9P9	437-0486-01
-33	174-4188-00			1	CA ASSY:RIBBON, (DISPLAY)	060D9	174-4188-00
-34	679-4379-00			1	CKT BD SUBASSY:CONNECTOR CONVERSION	80009	679-4379-00
-35	174-4231-00			1	CABLE ASSY:IDE CABLE ASSEMBY (HARD DRIVE)	060D9	174-4231-00

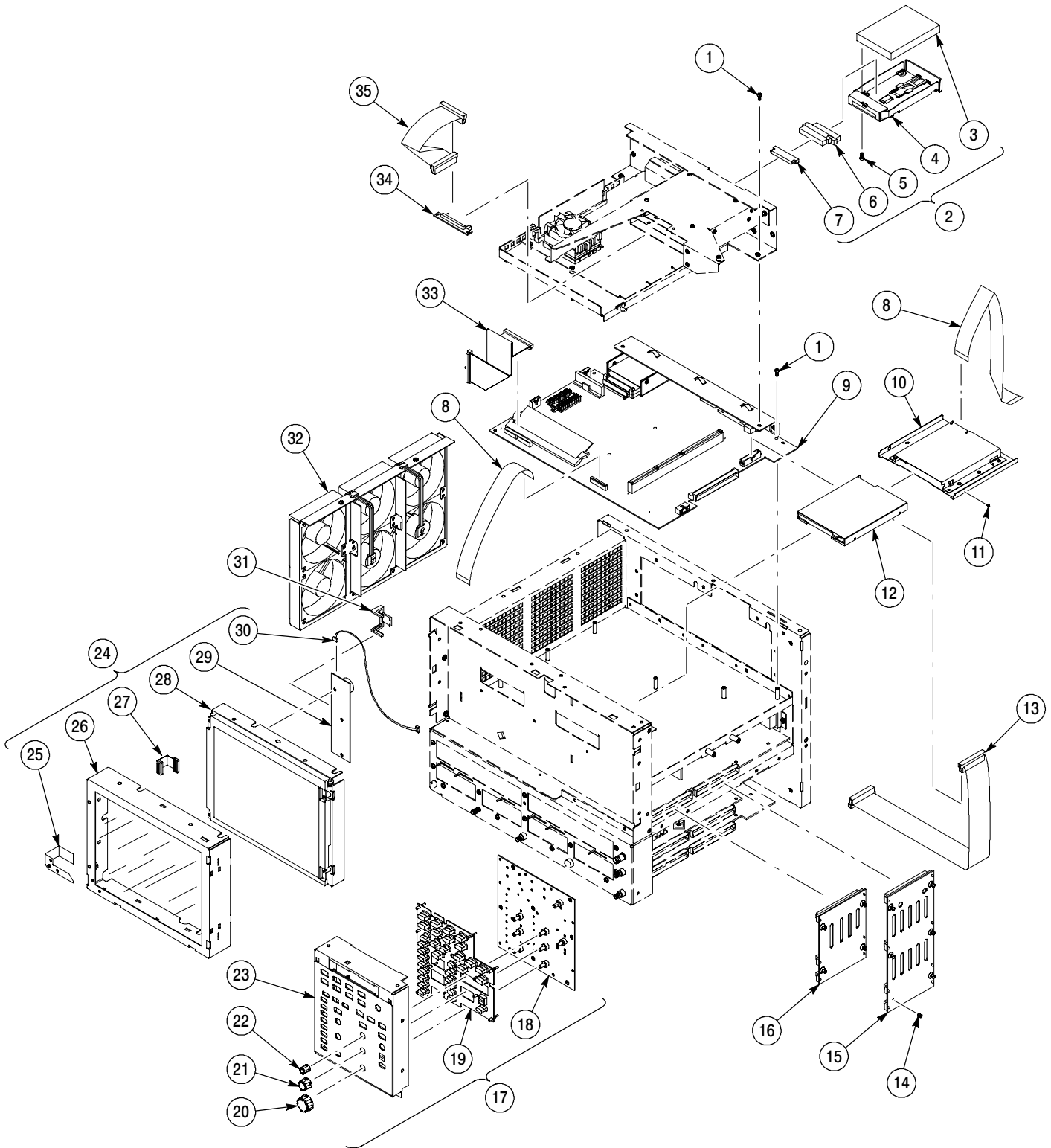

Figure 6-2: Front panel and drives

Replaceable Parts List

Fig. & index number	Tektronix part number	Serial no. effective	Serial no. discont'd	Qty	Name & description	Mfr. code	Mfr. part number
3-1	119-6511-00			1	IC,PROCESSOR:CMOS,MICROPROCESSOR,CELERON,566 MHZ,66MHZ BUS,SOCKET 370 COMPATIB	34649	BX80524P500128
-1A	119-6459-00			1	FAN,CHIP COOLER:12VDC,80MA,4400RPM,30DBA,64MM X 51MM X 31MM,W/HEATSINK & CLIP FOR CELERON	80009	119-6459-00
-2	214-3903-00			8	SCREW,JACK:4-40 X 0.312 LONG,0.188 H HEX HEAD STAND OFF,4-40 INT THD, X 0.312 THD EXT 4-40	05791	LT4276
-3	050-3506-00			1	NLX BOARD:MODIFY MOTHER BOARD NLX PROCESSOR	80009	039-0117-00
-4	211-1050-00			8	SCREW,MACHINE:6-32 X 0.312 L,PNH,STL CAD PLT,T15	0KB01	OBD
-5	679-4667-00			1	CKT BD SUBBASSY:RISER	80009	679-4667-00
-6	211-1050-00			4	SCREW,MACHINE:6-32 X 0.312 L,PNH,STL CAD PLT,T15	0KB01	OBD
-7	213-1061-00			2	JACKSCREW:6-32 X 0.320 EXT THD,M3.5 X 0.6-6 INT THD X 0.215L,GPIB	00779	554043-3
-8	386-7147-00			1	PANEL,I/O:ALUMINUM,POWER PC PROCESSOR	TK1943	386-7147-00
-9	131-6680-00			1	CONN HDR:CARDBUS HDR,SMD,MALE,RTANG,2 X 34	22526	61555-200CA
-10	211-0887-00			4	SCREW,METRIC:M2 X 0.4 X 16 MM L,PH,PHILLIPS DRIVE	0KB01	211-0887-00
-11	441-2172-00			1	CHASSIS ASSY:0.05 ALUM,13.65 X 16.50 X 3.55 (8000 ONLY)	0J9P9	441-2172-00
-11	441-2283-00			1	CHASSIS ASSY:MAIN,CENTER,FRONT,REAR & ACQUISITION CHASSIS,TDS8000B,CSA8000B	TK1943	441-2283-00
-12	119-5806-05			1	5.0V POWER SUPPLY:CUSTOM,AC-DC,375W,85-275VAC TDS8000, CSA8000	26003	119-5806-00
-12	119-6697-01			1	5.2V POWER SUPPLY:CUSTOM,AC-DC,375W,85-275VAC, TDS8000B, CSA8000B	26003	119-6697-01
-13	131-1315-01			1	CONN,RF JACK:BNC/PNL,50 OHM,FEMALE,STR,PELTOLA	24931	28JR306-1
-14	103-0269-00			3	ADAPTER,CONN:SMA TO PELTOLA,FEMALE TO FEMALE,STR,PNL,D/FLAT,0.385 MTG HOLE,GOLD/NICKEL	80009	103-0269-00
-15	131-0850-00			1	CONN,JACK,RF:SMA,FEEDTHRU,DUAL FEMALE,STR,50 OHM,0.25 MTG W/ 0.375HEX,0.59 X 0.24 MLG,GOLD/SS	26805	2084-0000-02
-16	210-0457-00			1	NUT,PL,ASSEM WA:6-32 X 0.312,STL CD PL,W/LOCKWASHER	0KB01	OBD
-17	210-0465-00			1	NUT,PLAIN,HEX:0.25-32 X 0.375,BRS CD PL	0KB01	OBD
-18	650-4086-00			1	CABLE ASSEMBLY:ELECT,ANTI STATIC CONNECTION	060D9	650-4086-00
-19	210-1443-00			1	WASHER,FLAT:0.25 ID X 0.375 OD X 0.265,NYLON	74594	5610-120-062
-20	136-0140-00			1	JACK,TIP:BANANA,CHARCOAL GRAY	0KBZ5	N/A
-21	156-4827-00			1	IC,MEMORY:CMOS,SDRAM,8MEG X 64,MC-458CB646-A10,DIMM168	6Y440	MT8LSDT864AG-10 EC7

Replaceable Parts List

Replaceable Parts List (cont.)

Fig. & index number	Tektronix part number	Serial no. effective	Serial no. discount'd	Qty	Name & description	Mfr. code	Mfr. part number
-22	441-2183-01	B010100	B010553	1	CHASSIS:REAR DRIVE BAY (HDD & CD-ROM) AL & STEEL (TDS8200)	TK1943	441-2183-01
	441-2183-03	B010554		1	CHASSIS:REAR DRIVE BAY (HDD & CD-ROM) AL & STEEL (TDS8200)	TK1943	441-2183-03
	441-2183-01	B010100	B010569	1	CHASSIS:REAR DRIVE BAY (HDD & CD-ROM) AL & STEEL (CSA8200)	TK1943	441-2183-01
	441-2183-03	B010570		1	CHASSIS:REAR DRIVE BAY (HDD & CD-ROM) AL & STEEL (CSA8200)	TK1943	441-2183-03
-23	407-4880-01			1	BRACKET,CD-ROM:STEEL	TK1943	407-4880-01
-24	174-4231-00			1	CABLE ASSY:CABLE ASSEMBY (CD-ROM)	060D9	174-4231-00
-25	671-4377-00			1	CIRCUIT BD ASSY:CD ROM INTERFACE	80009	671-4377-00
-26	119-5728-00	B010100	B010553	1	DISK DRIVE:OPTICAL,644MB,CD-ROM,16.7 MB/SEC (TDS8200)	50356	CD-224E-903
	119-5728-01	B010554		1	DISK DRIVE:OPTICAL,644MB,CD-ROM,16.7 MB/SEC (TDS8200)	50356	CD-224E-903
	119-5728-00	B010100	B010569	1	DISK DRIVE:OPTICAL,644MB,CD-ROM,16.7 MB/SEC (CSA8200)	50356	CD-224E-903
	119-5728-01	B010570		1	DISK DRIVE:OPTICAL,644MB,CD-ROM,16.7 MB/SEC (CSA8200)	50356	CD-224E-903
-27	211-1070-00			4	SCREW:M2 X 2MM,PNH,PHL, STL NI PLT	0KB01	211-1070-00
-28	441-2279-00			1	CHASSIS,NLX:ALUMINUM,W/HARDWARE	TK1943	441-2279-00
-29	211-0720-00			5	SCR,ASSEM WSHR:6-32,0.500,PNH,STL,CDPL,T-15	0KB01	OBD
-30	156-9074-00			1	IC,MEMORY:CMOS,SDRAM,16MEG X 64, SYNC, UNBUFFERED,3.3V,MC-4516CD646-A10,DIMM168 (CSA/TDS8000, CSA/TDS8000B)		MT16LSDT3264AG-10E
	156-9074-00	B010100	B010569	1	IC,MEMORY:CMOS,SDRAM,16MEG X 64, SYNC, UNBUFFERED,3.3V,MC-4516CD646-A10,DIMM168 (CSA8200)		MT16LSDT3264AG-10E
	156-9074-00	B010570		2	IC,MEMORY:CMOS,SDRAM,16MEG X 64, SYNC, UNBUFFERED,3.3V,MC-4516CD646-A10,DIMM168 (CSA8200)		MT16LSDT3264AG-10E
	156-9074-00	B010100	B010561	1	IC,MEMORY:CMOS,SDRAM,16MEG X 64, SYNC, UNBUFFERED,3.3V,MC-4516CD646-A10,DIMM168 (TDS8200)		MT16LSDT3264AG-10E
	156-9074-00	B010562		2	IC,MEMORY:CMOS,SDRAM,16MEG X 64, SYNC, UNBUFFERED,3.3V,MC-4516CD646-A10,DIMM168 (TDS8200)		MT16LSDT3264AG-10E

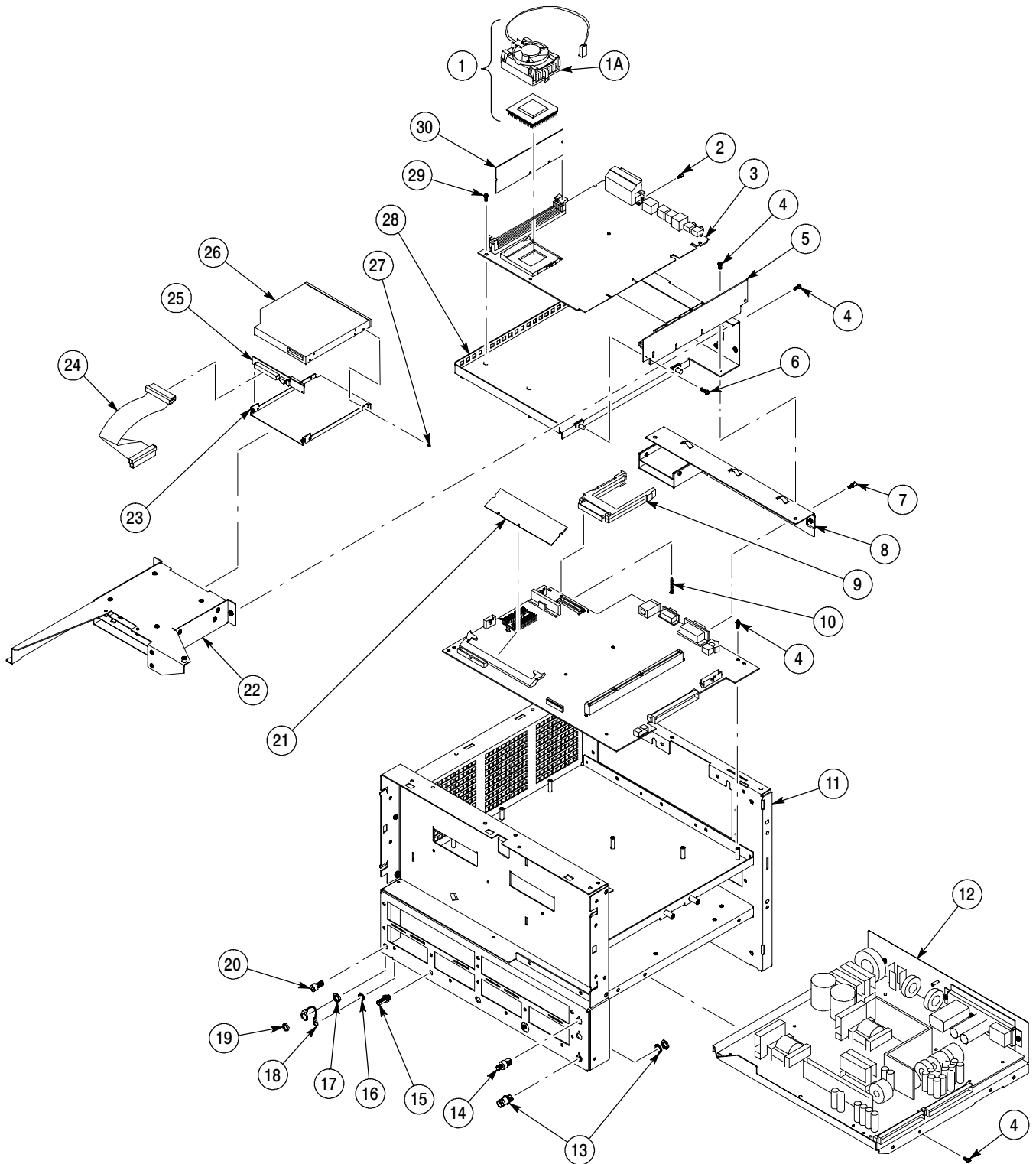

Figure 6-3: Power supply

Replaceable Parts List

Replaceable Parts List

Fig. & index number	Tektronix part number	Serial no. effective	Serial no. discont'd	Qty	Name & description	Mfr. code	Mfr. part number
4-1	441-2176-00			1	CHASSIS ASSY:LARGE MODULE,0.050 AL	OJ9P9	441-2176-00
-2	211-1050-00			21	SCREW,MACHINE:6-32 X 0.312 L,PNH,STL CAD PLT,T15	OKB01	211-1050-00
-3	671-4483-00			1	CIRCUIT BD ASSY:OPTICAL FRONT END	80009	671-4483-00
-4	174-4046-00			1	CA ASSY,SP:RIBBON,BUS PROCESSOR,IDC,32 AWG	060D9	174-4046-00
-5	351-1068-00			4	GUIDE:CARD GUIDE	32559	E-1000
-6	129-1516-00			3	SPACER, POST:ECB-1.077,0.250 HEX 12L 14 STEEL	TK0588	129-1516-00
-7	210-0457-00			20	NUT,PL,ASSEM WA:6-32 X 0.312,STL CD PL,W/LOCKWASHER	OKB01	210-0457-00
-8	174-4045-01			2	CA ASSY,SP:RIBBON,BUS ACQUISITION,IDC,32 AWG	060D9	174-4045-01
-9	Order 4-11			1	CIRCUIT BD ASSY:SMALL MODULE INTERFACE Part of item 4-11: COMBO ASSEMBLY:ACQP/EFE		NA
-10	Order 4-11			1	CKT BD SUBASSY:ACQ BOARD Part of item 4-11: COMBO ASSEMBLY:ACQP/EFE		NA
-11	650-4418-01			1	COMBO ASSEMBLY:ACQP/EFE (8000 AND 8000B)	80009	650-4418-01
	650-4608-00			1	COMBO ASSEMBLY:ACQP/EFE (8200)	80009	650-4608-00
-12	351-1067-00			8	GUIDE:CARD GUIDE,E-300	32559	E-300
-13	174-4043-00			1	CA ASSY,SP,ELEC:DISCRETE,TRIGGER PROBE POWER	060D9	174-4043-00
-14	211-0815-00			3	SCREW,MACHINE:6-32 X 1.750,PNH,STL,ZINC,T-15	3M099	211-0815-00
-15	174-4322-00			1	CA ASSY,RF:RFS,0.141OD,50 OHM,SMA,JACK, X SMA,JACK (8000 AND 8000B only)	060D9	174-4322-00
	174-4902-00			1	CA ASSY,RF:RFS,0.141OD,50 OHM,SMA,JACK, X SMA,JACK (8200 only)	060D9	174-4902-00
-16	441-2175-01			1	CHASSIS ASSY:SMALL MODULE,0.050 AL	OJ9P9	441-2175-01
-17	211-0373-00			18	SCREW,MACHINE:4-40 X 0.250,PNH,STL CD PLT,T10	93907	211-0373-00
-18	355-0259-00			4	STUD,LOCKING:0.850 X 0.188 HEX,SST	TK0588	355-0259-00
-19	214-4893-00			6	SPRING,TORSION:0.126OD X 0.094ID,DOOR,RIGHT,0.018DIA	8X345	R07SPRG4
-20	200-4560-00			4	COVER:SMALL MODULES,0.036 SST	TK1943	200-4560-00
-21	214-4892-00			6	SPRING,TORSION:0.126OD,0.094ID.DOOR,LEFT,0.018DIA	8X345	R07SPRG3
-22	105-1132-00			4	LEVER,EJECT:0.048 THK SSTL,SMALL MODULE	TK1943	105-1132-00
-23	210-0185-00			12	WASHER,SHLDR:0.375 OD X 0.115 ID X 0.093 THK	TK0588	210-0185-00
-24	366-0815-00			6	KNOB:EJECTOR LEVER,PC/ABS,SILVER GRAY	TK6181	366-0815-00
-25	105-1131-00			2	LEVER,EJECT:0.048 THK SSTL,LARGE MODULE	TK1943	105-1131-00
-26	214-4891-00			6	SPRING,TORSION:0.304 X 0.256 X 1.152	8X345	R07SPRG1
-27	355-0297-00			2	STUD,SHOULDERED:4-40 X 1.050L,SST	TK0588	355-0297-00
-28	200-4561-00			2	COVER:0.036 SST,LARGE MODULES	TK1943	200-4561-00
-29	200-4876-00			1	COVER, THERMAL, STOBE CIRCUITRY (8200 only)	OKB05	200-4876-00

Replaceable Parts List (cont.)

Fig. & index number	Tektronix part number	Serial no. effective	Serial no. discont'd	Qty	Name & description	Mfr. code	Mfr. part number
-30	211-0967-00			1	SCREW; 6-32X 0.25,PNH,STL,ZI PLT,T-15,W/CAPTIVE FLAT WASHER (8200 only)	0KB01	211-0967-00
-31	129-0208-00			1	SPACER,POST; 0.312 L,6-32 STUD,BRS,ELECTROLESS NICKEL,0.25 HEX (8200 only)	0KB01	129-0208-00

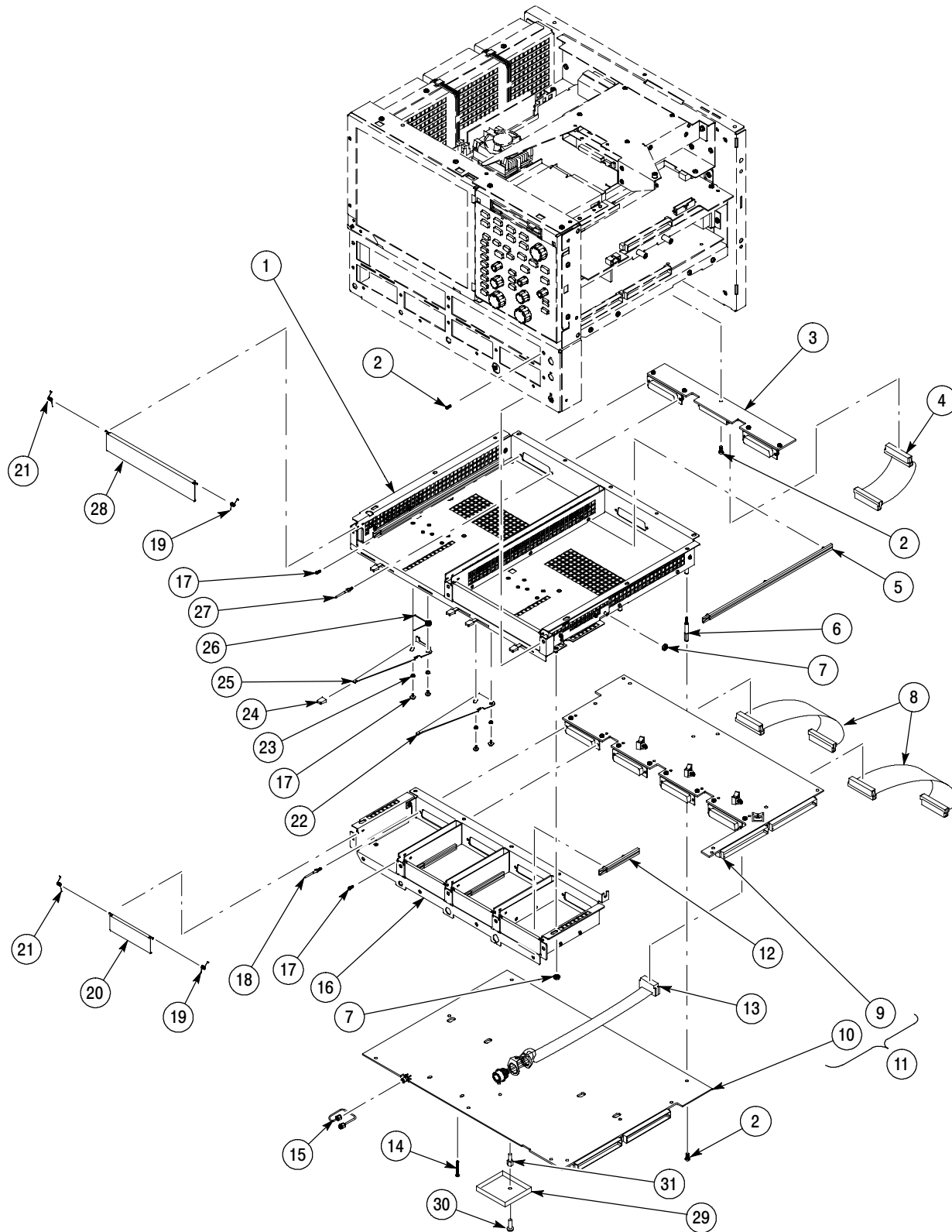

Figure 6-4: Acquisition

Replaceable Parts List

Fig. & index number	Tektronix part number	Serial no. effective	Serial no. discont'd	Qty	Name & description	Mfr. code	Mfr. part number
5-1	174-4348-00			2	CA ASSY, RF:COAXIAL,50 OHM,RG-316,12.00L,MCX RTANG PLUG 50 OHM TO MCX RTANG PLUG	060D9	174-4348-00
-2	174-4233-00			4	CA ASSY,RF:COAXIAL,50 OHM, DSUB TO MCX-B,R07CABL1	060D9	174-4233-00
-3	174-4347-00			10	CA ASSY,RF:COAXIAL,50 OHM,RG-316,7.500L,X D-SUB	060D9	174-4347-00
-4	174-4138-00			3	CABLE ASSY,RF:COAXIAL,50 OHM,OPTICAL BD TO ACQ BD	060D9	174-4138-00
-5	174-4132-00			1	CABLE ASSY,RF:COAXIAL,50 OHM,7.5 L,SMB TO PELTOLA	060D9	174-4132-00
-6	174-4133-00			4	CABLE ASSY,RF:COAXIAL,50 OHM,14.0 L,MCX TO PELTOLA	060D9	174-4133-00
-7	174-4137-00			2	CABLE ASSY,RF:COAXIAL,50 OHM,D-SUB TO ACQ BD	060D9	174-4137-00
-8	174-4234-01			1	CA ASSY,RF:COAXIAL,50 OHM, SMB TO MCX,R07CABL2	060D9	174-4234-01
	343-0459-00			1	STRAP,TIEDOWN,E:0.098 W X 4.0 L,ZYTEL (not shown on drawing)	74594	343-0459-00

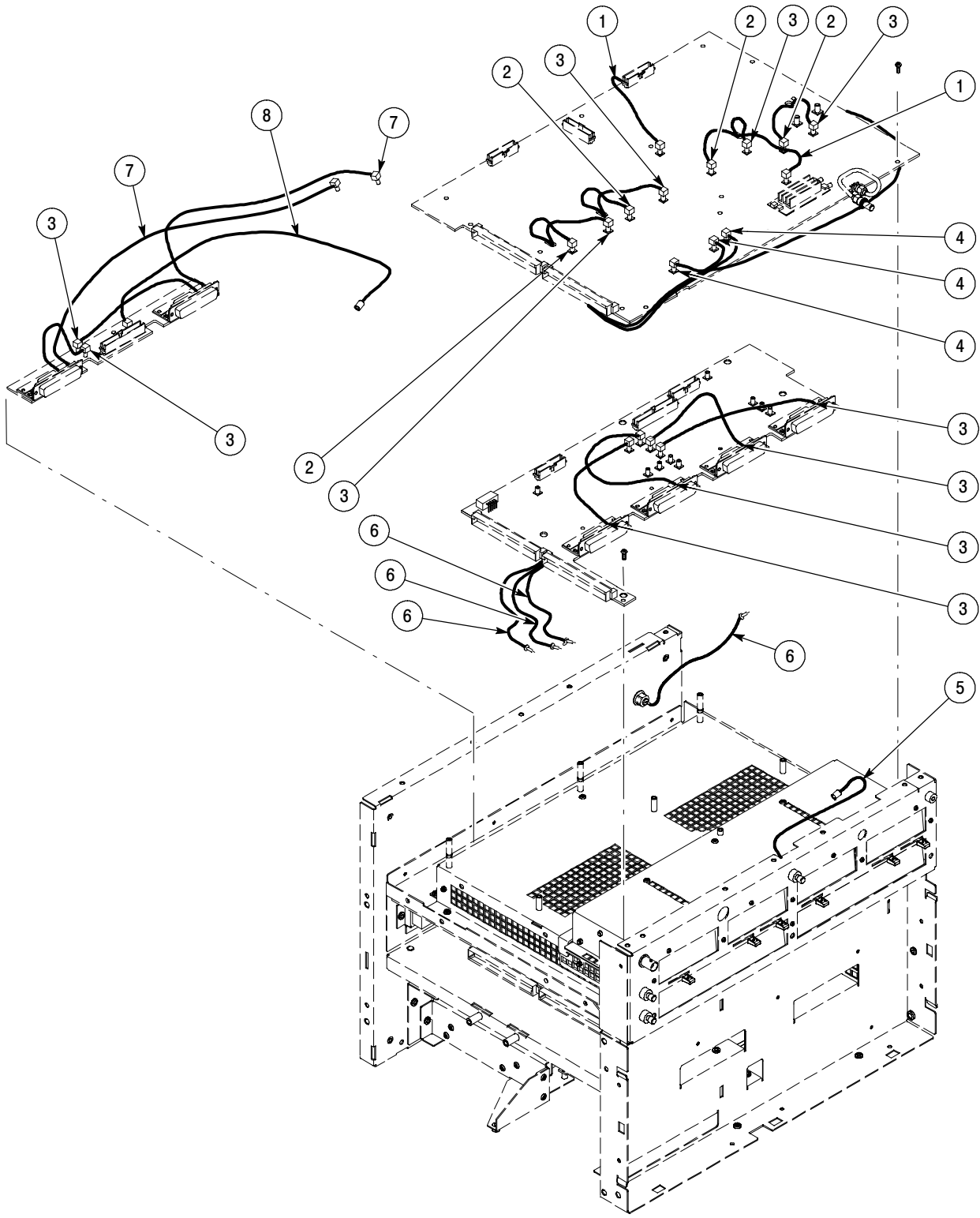

Figure 6-5: 8000 and 8000B coaxial cables

Replaceable Parts List

Fig. & index number	Tektronix part number	Serial no. effective	Serial no. discontinued	Qty	Name & description	Mfr. code	Mfr. part number
6-1	174-4348-00			2	CA ASSY, RF:COAXIAL,50 OHM,RG-316,12.00L,MCX RTANG PLUG 50 OHM TO MCX RTANG PLUG	060D9	174-4348-00
-2	174-4902-00			1	CABLE ASSEMBLY, RF TRIGGER PRESCALE	060D9	174-4902-00
-3	174-4347-00			4	CA ASSY,RF:COAXIAL,50 OHM,RG-316,7.500L,X D-SUB	060D9	174-4347-00
-4	174-4138-00			3	CABLE ASSY,RF:COAXIAL,50 OHM,OPTICAL BD TO ACQ BD	060D9	174-4138-00
-5	174-4132-00			1	CABLE ASSY,RF:COAXIAL,50 OHM,7.5 L,SMB TO PELTOLA	060D9	174-4132-00
-6	174-4133-00			1	CABLE ASSY,RF:COAXIAL,50 OHM,14.0 L,MCX TO PELTOLA	060D9	174-4133-00
-7	174-4137-00			2	CABLE ASSY,RF:COAXIAL,50 OHM,D-SUB TO ACQ BD	060D9	174-4137-00
-8	174-4234-01			1	CA ASSY,RF:COAXIAL,50 OHM, SMB TO MCX,R07CABL2	060D9	174-4234-01
-9	174-4882-00			2	CABLE ASSY,RF:COAXIAL,50 OHM,D-SUB TO ACQ BD	060D9	174-4882-00
	343-0459-00			1	STRAP,TIEDOWN,E:0.098 W X 4.0 L,ZYTEL (not shown on drawing)	74594	343-0459-00

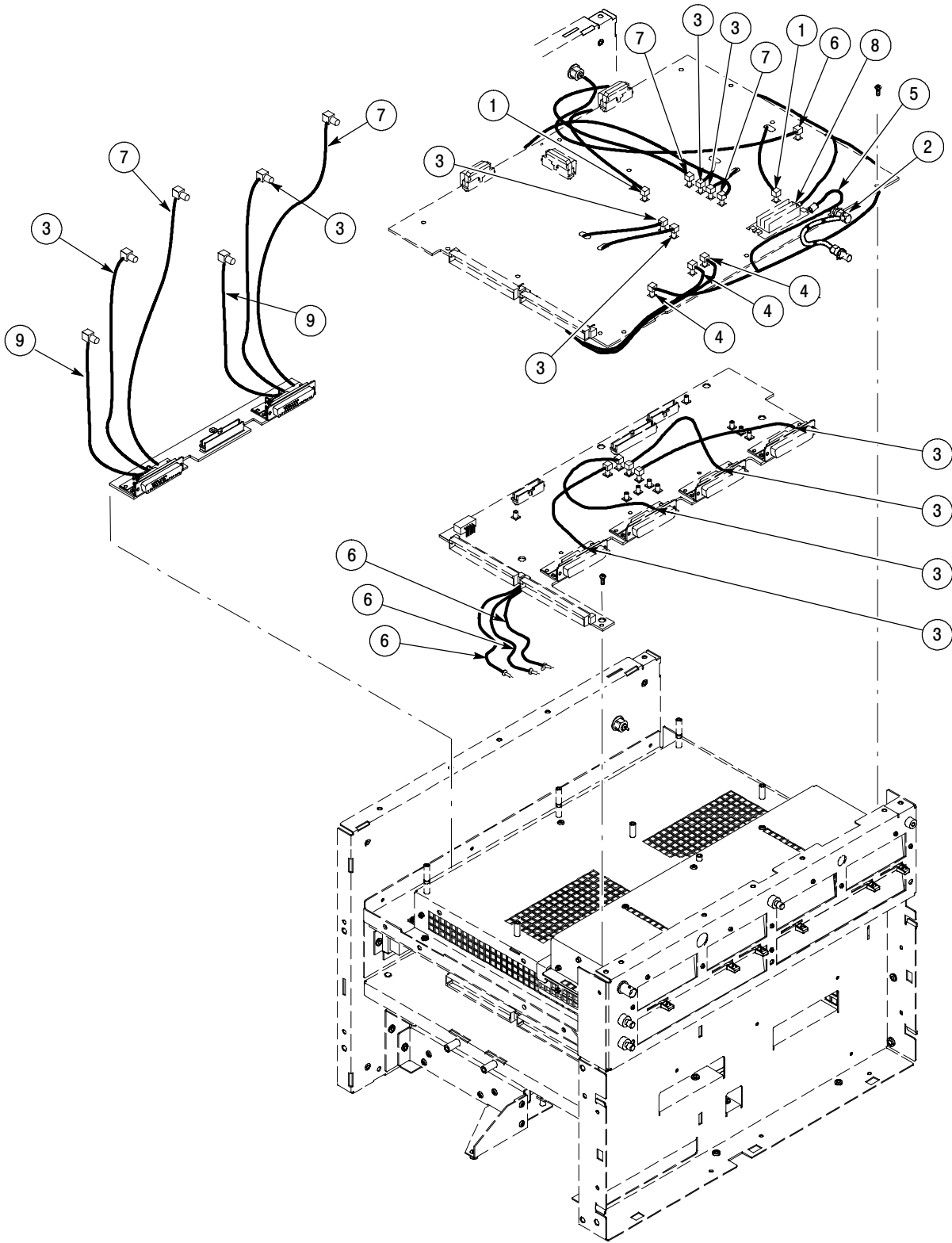

Figure 6-6: 8200 coaxial cables

Replaceable Parts List

Fig. & Index number	Tektronix part number	Serial no. effective	Serial no. discont'd	Qty	Name & description	Mfr. code	Mfr. part number
7-1	211-0088-00			3	SCREW,MACHINE:2-56 X 0.281,FLH,82 DEG,STL BK OXD,POZ	0KB01	211-0088-00
-2	386-7293-00			1	PLATE,FRICTION	TK2601	386-7293-00
-3	384-1838-00			1	SHAFT; SCREW LOCKDOWN, 303 SST, R05HDSCR	TK2563	384-1838-00
-4	391-0239-00			1	LOCK SCREW:MOUNTING BLOCK	TK2601	391-0239-00
-5	211-0088-00			4	SCREW,MACHINE:2-56 X 0.281,FLH,82 DEG,STL BK OXD,POZ	0KB01	OBD
-6	366-0804-00			1	KNOB:PUSH BUTTON, 0.11 OD, 0.33L, DELRIN, GRAY, 80E01	TK1163	366-0804-00 (R05PBKNB)
	366-0804-00			2	KNOB:PUSH BUTTON, 0.11 OD, 0.33L, DELRIN, GRAY, 80E02, 80E03, 80E04	TK1163	366-0804-00 (R05PBKNB)
-7	211-0087-00			2	SCREW,MACHINE:2-56 X 0.188,FLH,82 DEG SST,POZ	1AW87	211-0087-00
-8	214-4081-00			1	MTG,SCR LOCKDWN:ALUMINUM	5Y400	214-4081-00
-9	380-1132-00			1	HOUSING:SAMPLING HEAD,AL, 80E02	5Y400	380-1132-00
-10	333-4340-00			1	PANEL,FRONT:ALUMINUM,CHROMATE,W/TEK SILVERGRAY	5Y400	333-4340-00
-11	335-0151-00			1	MARKER,IDENT:LABEL,0.010 POLY,W/ADHESIVE,80E02	0KB05	335-0151-00
	335-0152-00			1	MARKER,IDENT:LABEL,0.010 POLY,W/ADHESIVE,80E03	0KB05	335-0152-00
	335-0153-00			1	MARKER,IDENT:LABEL,0.010 POLY,W/ADHESIVE,80E04	0KB05	335-0153-00
-12	380-1138-00			1	HOUSING:ALUMINUM,SAMPLING HEAD 80E01	5Y400	380-1138-00
-13	333-4371-00			1	PANEL,FRONT:ALUMINUM,CHROMATE,W/TEK SILVERGRAY	5Y400	333-4371-00
-14	335-0339-00			1	MARKER,IDENT:LABEL,0.010 POLY,W/ADHESIVE, 80E01	0KB05	335-0339-00

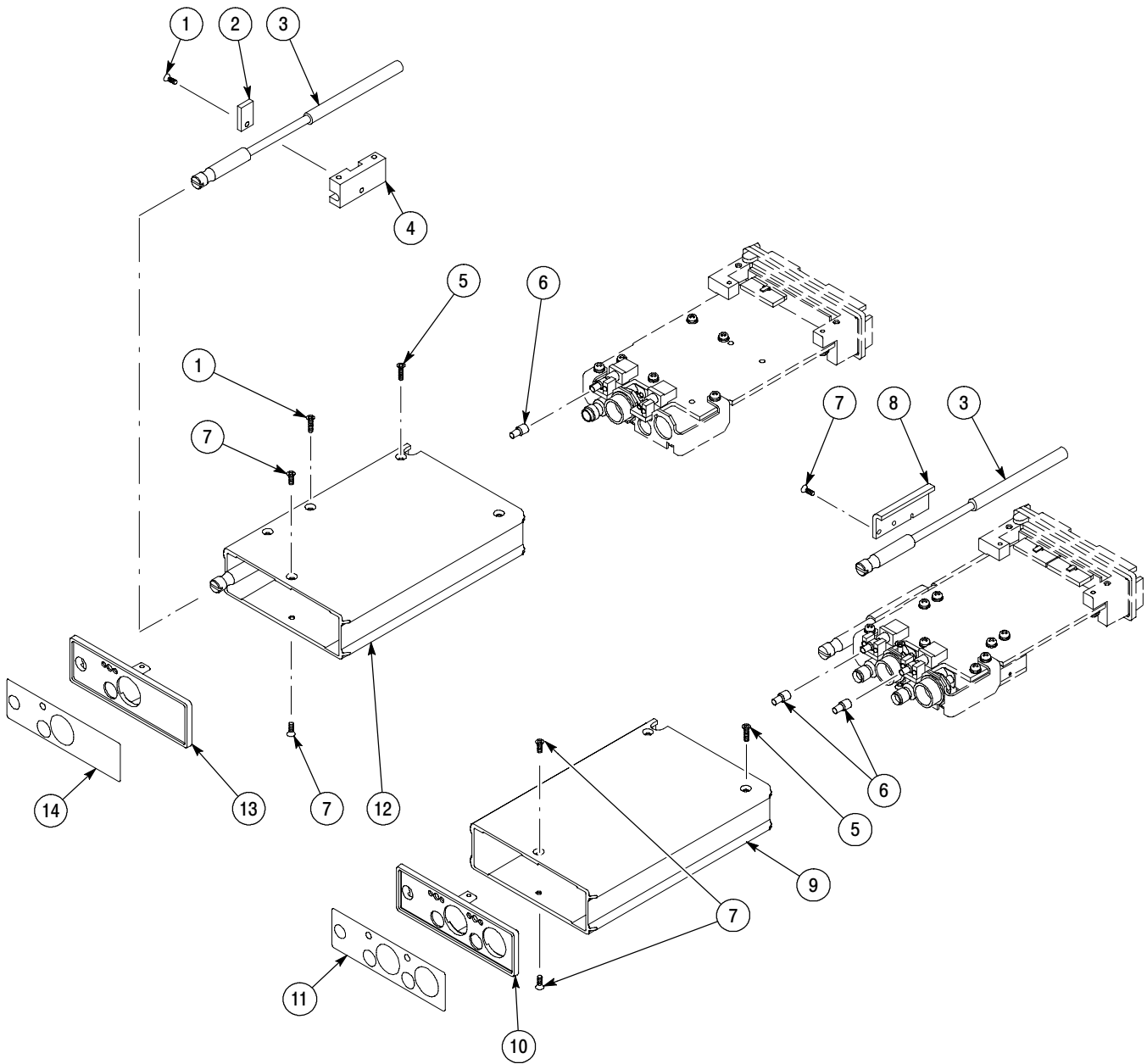

Figure 6- 7: 80E01, 80E02, 80E03, and 80E04 modules

Replaceable Parts List

Fig. & index number	Tektronix part number	Serial no. effective	Serial no. discont'd	Qty	Name & description	Mfr. code	Mfr. part number
8-1	200-4568-00			1	COVER:OPTICAL MODULE,0.050 AL	TK1943	200-4568-00
-2	335-0370-00			1	MARKER,IDENT:ANTI-STATIC LABEL,0.005 POLY	0KB05	335-0102-00
-3	211-0373-00			12	SCREW,MACHINE:4-40 X 0.250,PNH,STL CD PLT,T10	93907	211-0373-00
				13	SCREW,MACHINE:4-40 X 0.250,PNH,STL CD PLT,T10 (OPTION 10G)	93907	211-0373-00
-4	105-1115-00			2	LATCH:ADJUSTABLE GRIP,16-10-511-16	94222	16-10-511-16
-5	011-0176-00			5	TERM,RF; SMA,PLUG,STR,SST,W/BEAD CHAIN	61162	50T-315
				6	TERM,RF; SMA,PLUG,STR,SST,W/BEAD CHAIN (OPTION 10G)	61162	50T-315

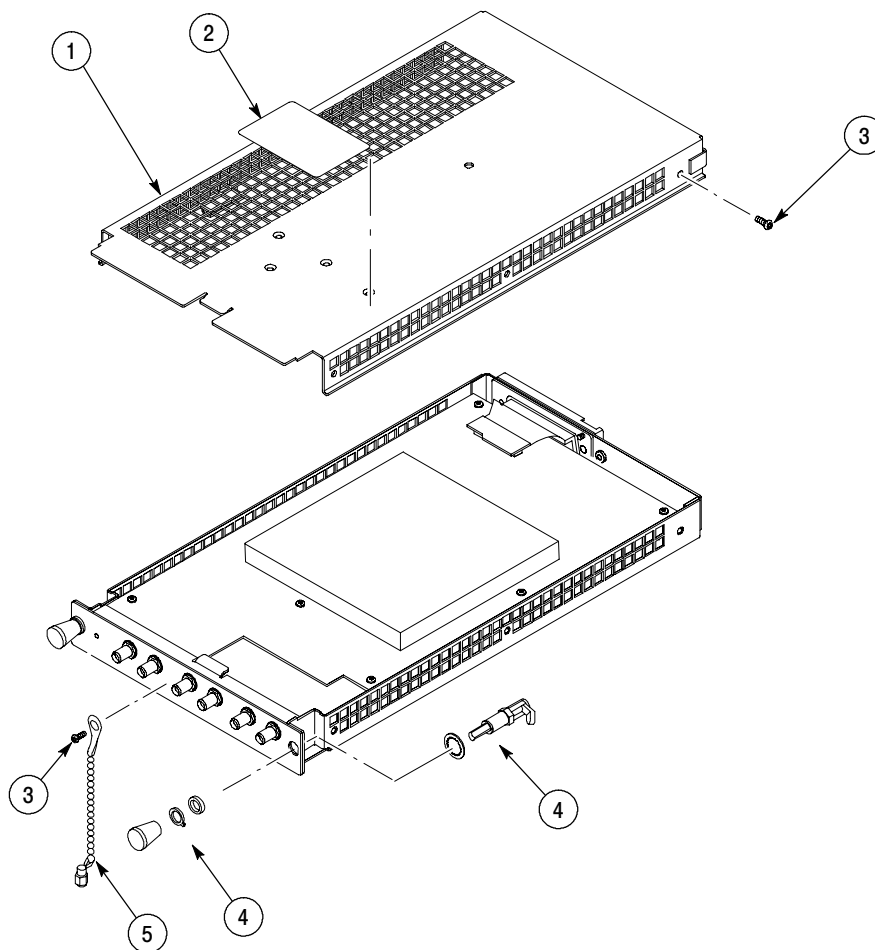

Figure 6-8: 80E05 module (Option 10G shown)

Replaceable Parts List

Fig. & index number	Tektronix part number	Serial no. effective	Serial no. discontinued	Qty	Name & description	Mfr. code	Mfr. part number
9-1	380-1159-00			1	HOUSING:SAMPLING HEAD,ALUMINUM,80E06, SAFETY CONTROLLED	5Y400	380-1159-00
-2	211-0087-00			2	SCREW,MACHINE:2-56 X 0.188,FLH,82 DEG SST,POZ	1AW87	211-0087-00
-3	333-4436-00			1	PANEL, FRONT:NSD HEADS,BLANK,386-5603-00,80E06	OJ4C1	333-4436-00
-4	335-0863-00			1	MARKER,IDENT:SAMPLING HEAD,2.760 X 0.810,0.010 POLY,W/ADHESIVE,80E06,SAFETY CONTROLLED	OKB05	335-0863-00
-5	211-0088-00			4	SCREW,MACHINE:2-56 X 0.281,FLH,82 DEG,STL BK OXD,POZ	OKB01	211-0088-00

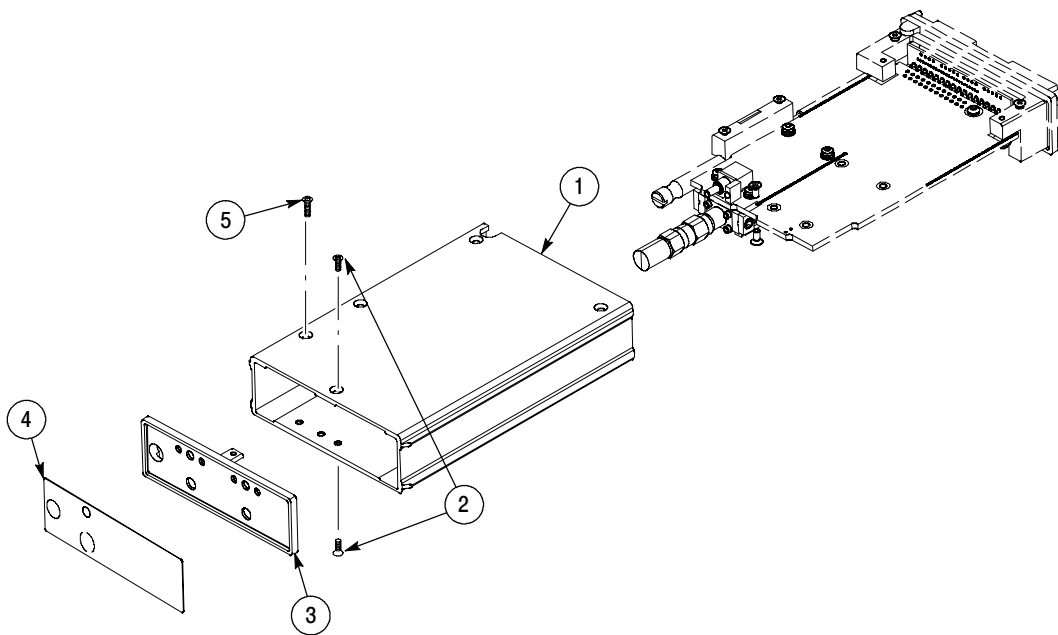

Figure 6- 9: 80E06 module

Replaceable Parts List

Fig. & index number	Tektronix part number	Serial no. effective	Serial no. discont'd	Qty	Name & description	Mfr. code	Mfr. part number
10-1	200-4568-00			1	COVER:OPTICAL MODULE,0.050 AL	TK1943	200-4568-00
-2	335-0370-00			1	MARKER,IDENT:ANTI-STATIC LABEL,0.005 POLY	0KB05	335-0102-00
-3	211-0373-00			7	SCREW,MACHINE:4-40 X 0.250,PNH,STL CD PLT,T10	93907	211-0373-00
-4	105-1115-00			2	LATCH:ADJUSTABLE GRIP,16-10-511-16	94222	16-10-511-16
-5	200-4104-00			1	CAP,DUST:ELAY M75-M80 SHORE,BLACK MATT TEXTURED	TK2491	UT11-01

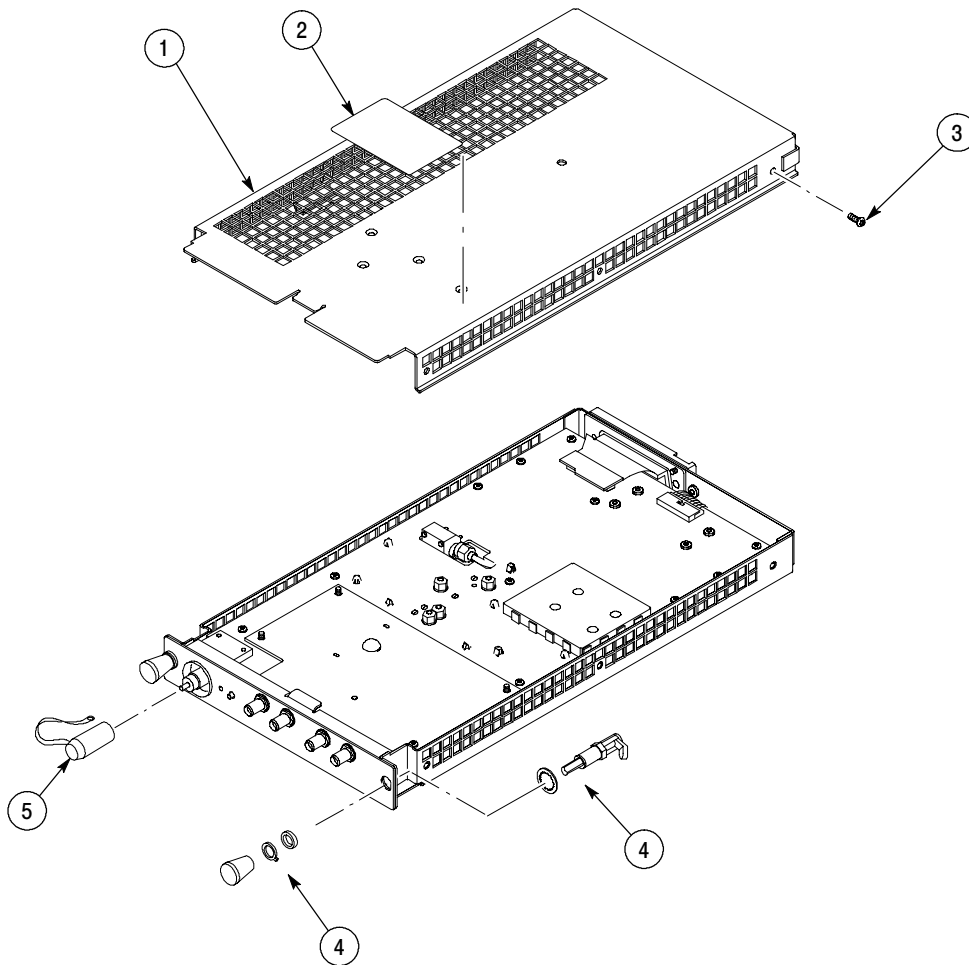

Figure 6-10: Optical modules

Replaceable Parts List

Fig. & Index number	Tektronix part number	Serial no. effective	Serial no. discont'd	Qty	Name & description	Mfr. code	Mfr. part number
11-1	384-1838-00			1	SHAFT:SCREW LOCKDOWN,303 SST,R05HDSCR	TK0588	384-1838-00
-2	214-4081-00			1	LOCKDOWN:SCREW MOUNT,0.080 AL	5Y400	214-4081-00
-3	211-3008-00			2	SCREW,MACHINE:2-56 X 0.281,PNH,SST,PASS,POZI DR	0KB01	211-3008-00
-4	015-1022-01			1	TERMINATOR:COAXIAL, 50 OHM, 0.5W, SMA	61162	50T-320 SMA M
-5	335-0370-00			1	MARKER,IDENT:ANTI-STATIC LABEL,0.005 POLY	0KB05	335-0102-00
-6	211-0088-00			8	SCREW,MACHINE:2-56 X 0.281,FLH,82 DEG,STL BK OXD,POZ	0KB01	211-0088-00
-7	380-1151-00			1	HOUSING:SAMPLING MODULE,TRIGGER PRESCALE LIMITING PREAMP	5Y400	380-1151-00
-8	211-0087-00			2	SCREW,MACHINE:2-56 X 0.188,FLH,82 DEG SST,POZ	1AW87	211-0087-00
-9	333-4392-00			1	PANEL,FRONT:TRIGGER PRESCALE LIMITING PREAMP,AL ALLOY	5Y400	333-4392-00
-10	335-0485-00			1	MARKER,IDENT:LABEL,MKD 80A01 PRESCALE MODULE,2.760 X .810,LEXAN,	0KB05	335-0485-00

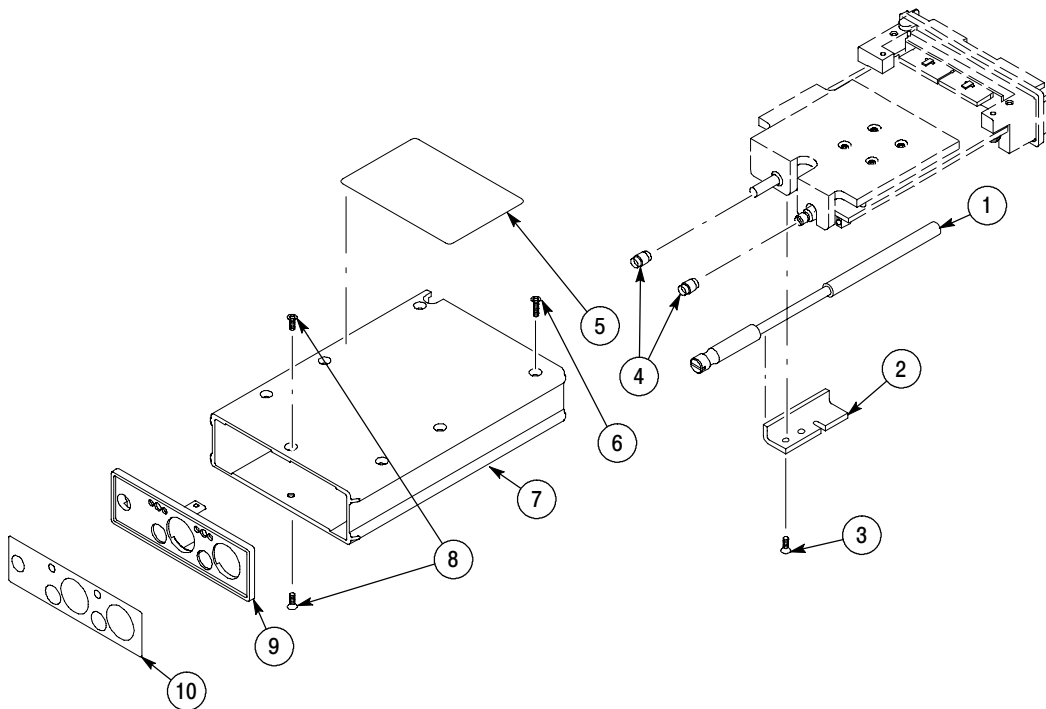

Figure 6- 11: 80A01 module

Replaceable Parts List

Fig. & index number	Tektronix part number	Serial no. effective	Serial no. discontinued	Qty	Name & description	Mfr. code	Mfr. part number
12-1	211-0088-00			8	SCREW,MACHINE:2-56 X 0.281,FLH,82 DEG,STL BK OXD,POZ	0KB01	211-0088-00
-2	386-7293-00			1	PLATE,FRICTION	TK2601	386-7293-00
-3	384-1838-00			1	SHAFT; SCREW LOCKDOWN, 303 SST, R05HDSCR	TK0588	384-1838-00
-4	391-0239-00			1	LOCK SCREW:MOUNTING BLOCK	TK2601	391-0239-00
-5	335-0370-00			1	MARKER,IDENT:ANTI-STATIC LABEL,0.005 POLY	0KB05	335-0102-00
-6	211-0087-00			3	SCREW,MACHINE:2-56 X 0.188,FLH,82 DEG SST,POZ	1AW87	211-0087-00
-7	380-1171-00			1	HOUSING:SAMPLING HEAD,ALUMINUM, SAFETY CONTROLLED	5Y400	380-1171-00
-8	333-4476-00			1	PANEL,FRONT:PHASE REF MODULE	5Y400	333-4476-00
-9	335-1036-00			1	MARKER,IDENT:LABEL,MKD 82A04 PHASE REF MODULE,2.760 X .810,LEXAN,	0KB05	335-1036-00
-10	015-1022-01			1	TERMINATOR:COAXIAL, 50 OHM, 0.5W, SMA	61162	50T-320 SMA M

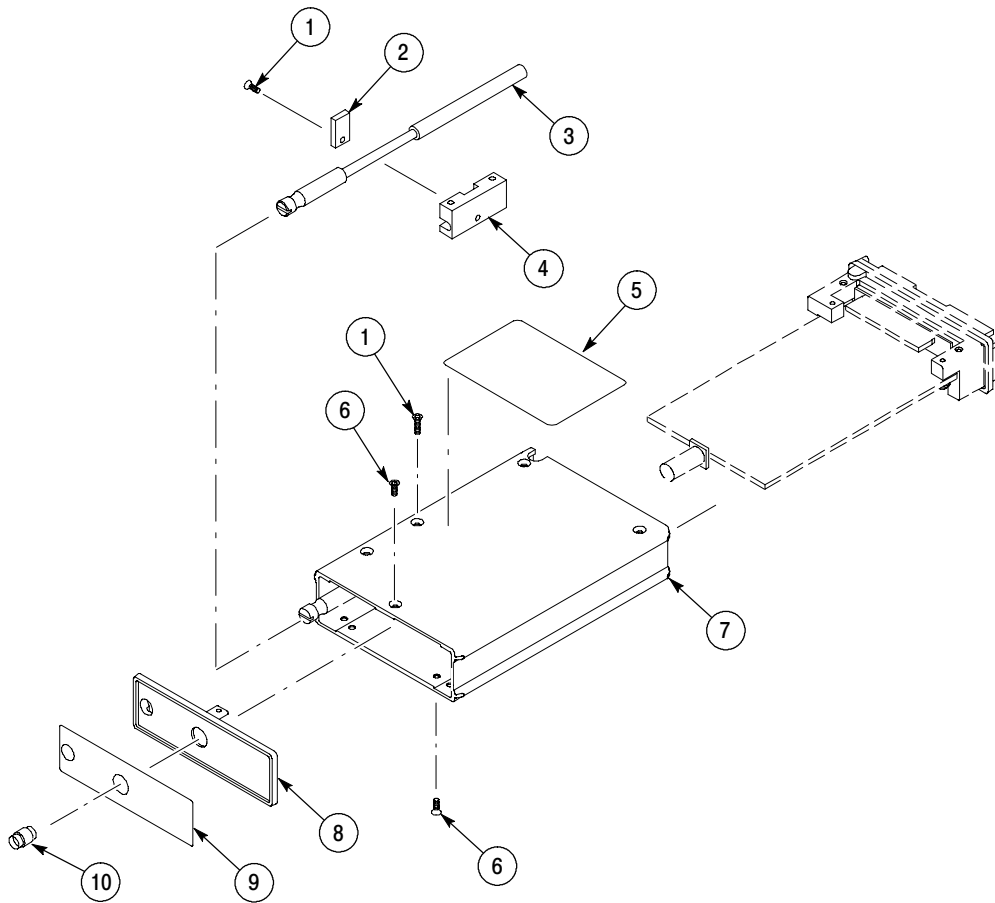

Figure 6- 12: 82A04 module

Replaceable Parts List

Fig. & index number	Tektronix part number	Serial no. effective	Serial no. discont'd	Qty	Name & description	Mfr. code	Mfr. part number
13-1	211-0088-00			6	SCREW,MACHINE:2-56 X 0.281,FLH,82 DEG,STL BK OXD,POZ	0KB01	211-0088-00
-2	386-7293-00			1	PLATE,FRICTION	TK2601	386-7293-00
-3	384-1838-00			1	SHAFT; SCREW LOCKDOWN, 303 SST, R05HDSCR	TK2563	384-1838-00
-4	391-0239-00			1	LOCK SCREW:MOUNTING BLOCK	TK2601	391-0239-00
-5	335-0370-00			1	MARKER,IDENT:ANTI-STATIC LABEL,0.005 POLY	0KB05	335-0370-00
-6	211-0087-00			2	SCREW,MACHINE:2-56 X 0.188,FLH,82 DEG SST,POZ	1AW87	211-0087-00
-7	380-1159-00			1	HOUSING:SAMPLING HEAD,ALUMINUM, SAFETY CONTROLLED	5Y400	380-1159-00
-8	333-3451-00			1	PANEL,FRONT:PATTERN TRIGGER	5Y400	333-3451-00
-9	335-1317-00			1	MARKER,IDENT:LABEL,MKD 80A06 PATTERN TRIGGER MODULE,2.760 X .810,LEXAN,	0KB05	335-1317-00
-10	344-0623-00			3	CLIP, SMA CONNECTOR FOR TERMINATION W/CHAIN, POLYPROPYLENE, SILVER GRAY	80009	344-0623-00
-11	011-0176-00			3	TERM,RF; SMA,PLUG,STR,SST,W/BEAD CHAIN	61162	50T-315

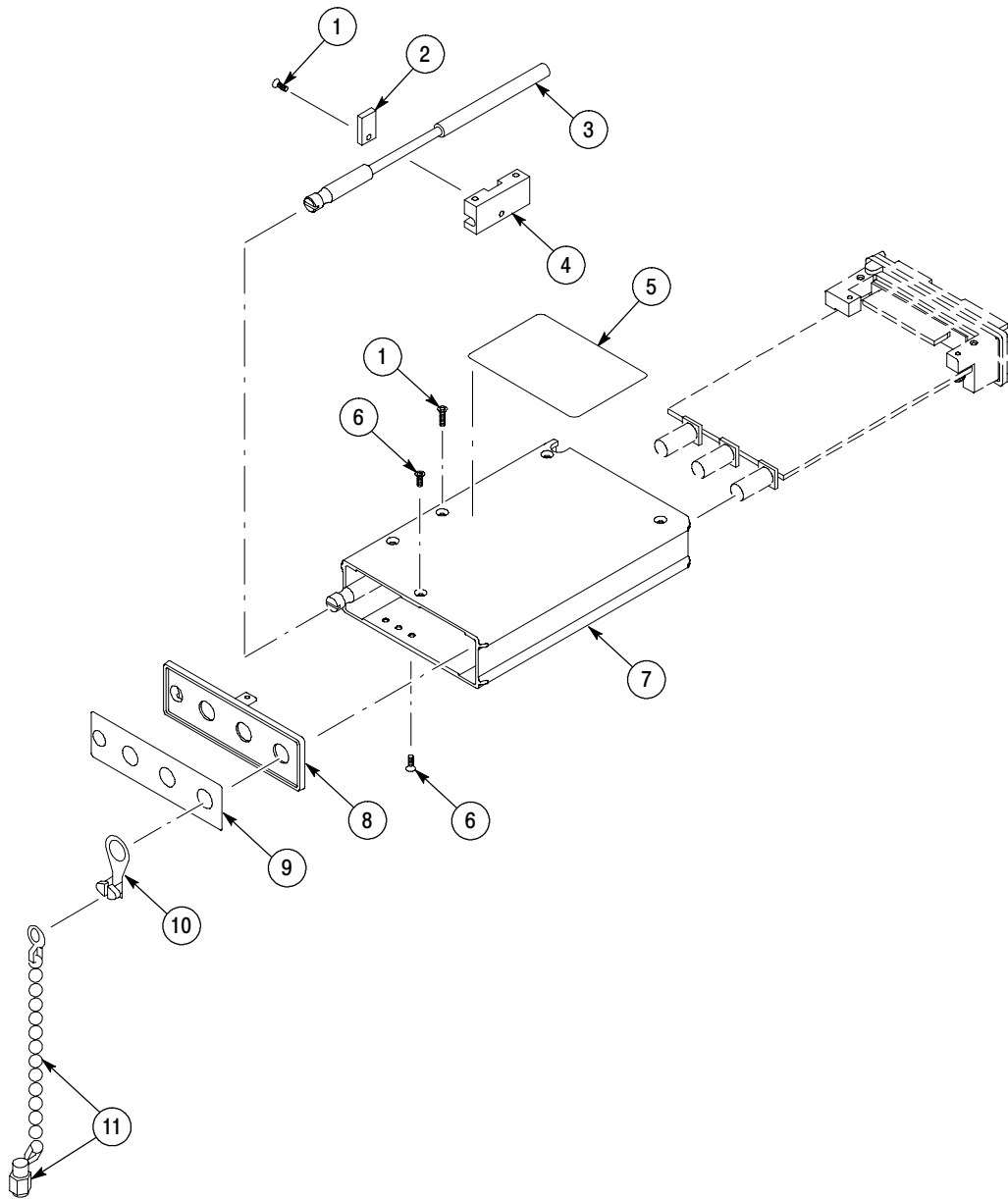

Figure 6- 13: 80A06 module

Replaceable Parts List

Tektronix part number	Serial no. effective	Serial no. discont'd	Qty	Name & description	Mfr. code	Mfr. part number
MAINFRAME STANDARD ACCESSORIES						
161-0104-05			1	CA ASSY,PWR:3,1.0MM SQ,250V/10A,2.5 M (OPTION A3 - AUSTRALIAN)	S3109	198-010
161-0104-06			1	CA ASSY,PWR:3,1.0MM SQ,250V/10A,2.5 M (OPTION A1 - EUROPEAN)	S3109	198-010
161-0104-07			1	CA ASSY,PWR:3,1.0MM SQ,240V/10A,2.5 M (OPTION A2 - UNITED KINGDOM)	S3109	209010
161-0167-00			1	CA ASSY,PWR:3,0.75MM SQ,250V/10A,2.5 M (OPTION A5 - SWITZERLAND)	S3109	ORDER BY DESC
161-0306-00			1	CA ASSY,PWR:3,1.0MM SQ,250V/10A,2.5 M (OPTION AC - CHINA)	TK6253	92-2637-250BKH
161-A005-00			1	CA ASSY,PWR; RT ANGLE, (OPTION A6 - JAPAN)	TK6121	3272WVTF78.2
-----			1	CABLE ASSY,PWER:3,18 AWG,92 L (STANDARD CABLE - SEE FIG 10-1-6)		
016-1268-00			1	POUCH, PLASTIC:POUCH (STANDARD CABLE - SEE FIG 10-1-1)	TK2539	2122
020-2370-XX			1	ACCESSORY KIT:SOFTWARE PACKAGING KIT, CSA8000, TDS8000, CSA8000B, TDS8000B	TK2548	020-2370-XX
020-2526-XX			1	ACCESSORY KIT; PRODUCT SOFTWARE KIT,V2.0; 8000 SERIES	TK2548	020-2526-XX
020-2436-XX			1	ACCESSORY KIT:WINDOWS OPERATING SYSTEM RESTORE SOFTWARE,W/TEK ENVELOPES & CD BOOKLET CSA8000, TDS8000, CSA8000B, TDS8000B	TK2548	020-2436-XX
020-2527-XX			1	ACCESSORY KIT; WINDOWS OPERATING SYSTEM RESTORE SOFTWARE,WIN2K, W/TEK ENVELOPES & CD BOOKLET 8000 SERIES	TK2548	020-2527-XX
020-2543-XX			1	ACCESSORY KIT; PRODUCT DOCUMENTATION CD,W/BOOK-LET;CSA8000 & TDS8000 SERIES	TK2548	020-2543-XX
071-0433-XX			1	MANUAL,TECH:USER, CSA8000, TDS8000, CSA8000B, TDS8000B	TK2548	071-0433-XX
071-1096-XX			1	MANUAL,TECH:REFERENCE, CSA8000B, TDS8000B	TK2548	071-1096-XX
071-1099-XX			1	MANUAL,TECH:USER, CSA8000B, TDS8000B	TK2548	071-1099-XX
071-1482-XX			1	MANUAL,TECH:QUICK START USER, CSA8200, TDS8200	TK2548	071-1482-XX
119-6633-00			1	KEYBOARD:USB KEYBOARD CSA8000, TDS8000, CSA8000B, TDS8000B	52833	E06101 USB-C
119-7083-00			1	KEYBOARD; USB W/ 2-PORT HUB; MINI (69 KEYS) BLACK; HAPPY HACKING, SAFETY CONTROLLED; CSA8200, TDS8200	304371	PD-KB200B/U
119-6298-00			1	MOUSE:LOGITECCH WHEEL MOUSE CSA8000, TDS8000, CSA8000B, TDS8000B	46628	830306-001
119-7054-00			1	POINTER ASSY; MOUSE,MICROSOFT BLACK OPTICAL WHEELED,USB AND PS2,SAFETY CONTROLLED; CSA8200, TDS8200	65405	D66-00066
119-6107-00			1	STYLUS:STYLUS FOR TOUCH SCREEN	03ZT7	T1100
MAINFRAME OPTIONAL ACCESSORIES						
012-1568-00				CA ASSY:SSP,ELEC,1 METER LONG, EXTENDER	060D9	012-1568-00
012-1569-00				CA ASSY:SSP,ELEC,2 METER LONG, EXTENDER	060D9	012-1569-00
015-0552-00				ADPTR,APC,ELEC:3.5MM,MALE TO FEMALE	02660	131-7053
015-0553-00				ADPTR,SMA,ELEC:MALE TO FEMALE,SLIDE ON MALE	98291	50-674-6324-990

Replaceable Parts List

Replaceable Parts List (cont.)

Tektronix part number	Serial no. effective	Serial no. discont'd	Qty	Name & description	Mfr. code	Mfr. part number
015-1001-01				ATTENUATOR, FIX:2:1 ATTENUATION, 50 OHM, SMA SERIES CONNECTORS	16179	2082-4573-06
015-1002-01				ATTENUATOR, FIX:5:1 ATTENUATION, 50 OHM, SERIES SMA CONNECTORS	16179	2082-4573-14
015-0565-00				POWER DIVIDER:50 OHM, 3 SMA FEMALE CONNECTORS	64537	D293S
016-1791-01				RACKMOUNT KIT: OPTION 1R, CSA/TDS8000 SERIES	80009	016-1791-01
067-1338-00				FIXTURE,CAL.:SAMPLING HEAD CAL UNIT	TK2601	067-1338-00
071-0438-XX				MANUAL,TECH:SERVICE, CSA8000, TDS8000, CSA8000B, TDS8000B, CSA8200, TDS8200	TK2548	071-0438-XX
071-1745-XX				MANUAL,TECH:SPECIFICATIONS AND PERFORMANCE VARIFICATION, CSA8000, TDS8000, CSA8000B, TDS8000B, CSA8200, TDS8200	TK2548	071-1745-XX
650-4271-00				DISK DRIVE:WINCHESTER,2.5 IN,10.0 GB SINGLE PLATTER,9.5 MM,IDE,MHH2064AT,	80009	650-4271-00
-----				DUAL DELAY LINE: DL-11	80009	DL-11
-----				PROBE: P6209, 4.0 GHz ACTIVE FET PROBE	80009	P6202
-----				EOS/ESD PROTECTION MODULE:ELECTRICAL STATIC ISOLATION OF TEKTRONIX ELECTRICAL SAMPLING MODULES	80009	80A02
80E0X STANDARD ACCESSORIES						
015-1022-00			1	TERMINATOR, COA:SHORT CIRCUIT, SMA MALE (80E01)	0GZV8	64SMA-50-0-1
015-1022-00			2	TERMINATOR, COA:SHORT CIRCUIT, SMA MALE (80E02, 80E03 AND 80E04)	0GZV8	64SMA-50-0-1
015-0703-xx			1	ADPTR,RF,PRCN:2.4MM OR 1.85MM MALE TO 2.92MM FEMALE (80E01 and 80E06 only)	20944	26-925-0000-90
80E0X OPTIONAL ACCESSORIES						
071-0434-XX			1	MANUAL,TECH:SAMPLING MODULE USER	TK2548	071-0434-XX
012-1568-00			1	CA ASSY:SPP,ELEC,1 METER LONG, EXTENDER	060D9	012-1568-00
012-1569-00			1	CA ASSY:SPP,ELEC,2 METER LONG, EXTENDER	060D9	012-1569-00
015-1001-00			1	ATTENUATOR, FIX:2:1 ATTENUATION, 50 OHM, SERIES SMA CONNECTORS	16179	2082-4573-06
015-1002-01			1	ATTENUATOR, FIX:5:1 ATTENUATION, 50 OHM, SERIES SMA CONNECTORS	16179	2082-4573-14
80C0X OPTIONAL ACCESSORIES						
071-0435-XX			1	MANUAL,TECH:OPTICAL MODULE USER	TK2548	071-0435-XX
119-4514-00			1	ADAPTER,D4:TFS3030,AD4-20	TK2491	AD4-20
119-4515-00			1	ADAPTER,BICONIC:TFS3030,AB1-25	TK2491	ABI-25
119-4516-00			1	CONNECTOR, OPTO:ADAPTER, FC-PC, ATTN 0.6DB, RTN LOSS 35DB, RPTB+/-0.2DB, RIFOCS, APC-10	TK2491	APC-10
119-4517-00			1	ADAPTER,SMA:TFS3030,2.5MM,AMT-10	TK2491	AMT-10
119-4518-00			1	ADAPTER,SC:TFS3030,ASC-10	TK2491	ASC-10
119-4546-00			1	ADAPTER,DIN:47256,AD-234	TK2491	AD-234

Replaceable Parts List (cont.)

Tektronix part number	Serial no. effective	Serial no. discont'd	Qty	Name & description	Mfr. code	Mfr. part number
119-4556-00			1	ADAPTER,HP-PC:OPTICAL CONNECTOR, UNIVERSAL CONNECTOR INTERFACE, AHP-10	TK2491	PROPRIETARY INFORMATION (AHP-10)
119-4557-00			1	ADAPTER,UNIV:SMA 905/906,ASM-90	TK2491	PROPRIETARY INFORMATION (ASM-90)
119-4558-00			1	ADAPTER,UNIV:DIAMOND 3.5MM,AMS-00	TK2491	PROPRIETARY INFORMATION (AMS-00)
119-4513-00			1	CONNECTOR, OPTO:ADAPTER, ST, ATTEN 0.6DB, RTN LOSS 35DB, RPTB +/-0.2DBRIFOCS, ATS-16	TK2491	ATS-16

